



Industrial Automation Headquarters

Delta Electronics, Inc.
Taoyuan Technology Center
No.18, Xinglong Rd., Taoyuan City,
Taoyuan County 33068, Taiwan
TEL: 886-3-362-6301 / FAX: 886-3-371-6301

Asia

Delta Electronics (Jiangsu) Ltd.
Wujiang Plant 3
1688 Jiangxing East Road,
Wujiang Economic Development Zone
Wujiang City, Jiang Su Province,
People's Republic of China (Post code: 215200)
TEL: 86-512-6340-3008 / FAX: 86-769-6340-7290

Delta Greentech (China) Co., Ltd.
238 Min-Xia Road, Pudong District,
ShangHai, P.R.C.
Post code : 201209
TEL: 86-21-58635678 / FAX: 86-21-58630003

Delta Electronics (Japan), Inc.
Tokyo Office
2-1-14 Minato-ku Shibadaimon,
Tokyo 105-0012, Japan
TEL: 81-3-5733-1111 / FAX: 81-3-5733-1211

Delta Electronics (Korea), Inc.
1511, Byucksan Digital Valley 6-cha, Gasan-dong,
Geumcheon-gu, Seoul, Korea, 153-704
TEL: 82-2-515-5303 / FAX: 82-2-515-5302

Delta Electronics Int'l (S) Pte Ltd
4 Kaki Bukit Ave 1, #05-05, Singapore 417939
TEL: 65-6747-5155 / FAX: 65-6744-9228

Delta Electronics (India) Pvt. Ltd.
Plot No 43 Sector 35, HSIIDC
Gurgaon, PIN 122001, Haryana, India
TEL : 91-124-4874900 / FAX : 91-124-4874945

Americas

Delta Products Corporation (USA)
Raleigh Office
P.O. Box 12173, 5101 Davis Drive,
Research Triangle Park, NC 27709, U.S.A.
TEL: 1-919-767-3800 / FAX: 1-919-767-8080

Delta Greentech (Brasil) S.A
Sao Paulo Office
Rua Itapeva, 26 - 3° andar Edificio Itapeva One-Bela Vista
01332-000-São Paulo-SP-Brazil
TEL: +55 11 3568-3855 / FAX: +55 11 3568-3865

Europe

Deltronics (The Netherlands) B.V.
Eindhoven Office
De Witbogt 20, 5652 AG Eindhoven, The Netherlands
TEL: 31-40-2592850 / FAX: 31-40-2592851

*We reserve the right to change the information in this catalogue without prior notice.

Delta Elevator Drive VFD-ED Series User Manual



Delta Elevator Drive VFD-ED Series User Manual



www.deltaww.com

www.importsnab24.ru



Thank you for choosing DELTA's high-performance VFD-ED Series. The VFD-ED Series is manufactured with high-quality components and materials and incorporates the latest microprocessor technology available.

This manual is to be used for the installation, parameter setting, troubleshooting, and daily maintenance of the AC motor drive. To guarantee safe operation of the equipment, read the following safety guidelines before connecting power to the AC motor drive. Keep this operating manual at hand and distribute to all users for reference.

To ensure the safety of operators and equipment, only qualified personnel familiar with AC motor drive are to do installation, start-up and maintenance. Always read this manual thoroughly before using VFD-ED series AC Motor Drive, especially the WARNING, DANGER and CAUTION notes. Failure to comply may result in personal injury and equipment damage. If you have any question, please contact your dealer.

PLEASE READ PRIOR TO INSTALLATION FOR SAFETY.



1. AC input power must be disconnected before any wiring to the AC motor drive is made.
2. A charge may still remain in the DC-link capacitors with hazardous voltages, even if the power has been turned off. To prevent personal injury, please ensure that power has turned off before opening the AC motor drive and wait ten minutes for the capacitors to discharge to safe voltage levels.
3. Never reassemble internal components or wiring.
4. The AC motor drive may be destroyed beyond repair if incorrect cables are connected to the input/output terminals. Never connect the AC motor drive output terminals U/T1, V/T2, and W/T3 directly to the AC mains circuit power supply.
5. Ground the VFD-ED using the ground terminal. The grounding method must comply with the laws of the country where the AC motor drive is to be installed. Refer to the Basic Wiring Diagram.
6. VFD-ED series is used only to control variable speed of 3-phase induction motors, NOT for 1-phase motors or other purpose.
7. VFD-ED series shall NOT be used for life support equipment or any life safety situation.



1. DO NOT use Hi-pot test for internal components. The semi-conductor used in AC motor drive easily damage by high-voltage.
2. There are highly sensitive MOS components on the printed circuit boards. These components are especially sensitive to static electricity. To prevent damage to these components, do not touch these components or the circuit boards with metal objects or your bare hands.
3. Only qualified persons are allowed to install, wire and maintain AC motor drives.



1. Some parameters settings can cause the motor to run immediately after applying power.
2. DO NOT install the AC motor drive in a place subjected to high temperature, direct sunlight, high humidity, excessive vibration, corrosive gases or liquids, or airborne dust or metallic particles.
3. Only use AC motor drives within specification. Failure to comply may result in fire, explosion or electric shock.
4. To prevent personal injury, please keep children and unqualified people away from the equipment.
5. When the motor cable between AC motor drive and motor is too long, the layer insulation of the motor may be damaged. Please use a frequency inverter duty motor or add an AC output reactor to prevent damage to the motor. Refer to appendix B Reactor for details.
6. The rated voltage for AC motor drive must be $\leq 240V$ ($\leq 480V$ for 460V models) and the mains supply current capacity must be $\leq 5000A$ RMS ($\leq 10000A$ RMS for the $\geq 40hp$ (30kW) models)

Firmware version: 1.01

01 Introduction

1-1 Receiving and Inspection

After receiving the AC motor drive, please check for the following:

- 1) Inspect the unit after unpacking to assure it was not damaged during shipment. Make sure that the part number printed on the package corresponds with the part number indicated on the nameplate.
- 2) Make sure that the voltage for the wiring lie within the range as indicated on the nameplate. Install the AC motor drive according to this manual.
- 3) Before applying the power, make sure that all the devices, including power, motor, control board and digital keypad, are connected correctly.
- 4) When wiring the AC motor drive, make sure that the wiring of input terminals “R/L1, S/L2, T/L3” and output terminals”U/T1, V/T2, W/T3” are correct to prevent drive damage.
- 5) When power is applied, select the language and set parameter groups via the digital keypad (KPED-LE01). When executing a trial run, begin with a low speed and then gradually increase the speed untill the desired speed is reached.

1-2 Nameplate Information

Using 15HP/11kW 230V, 3-Phase as an exemple.

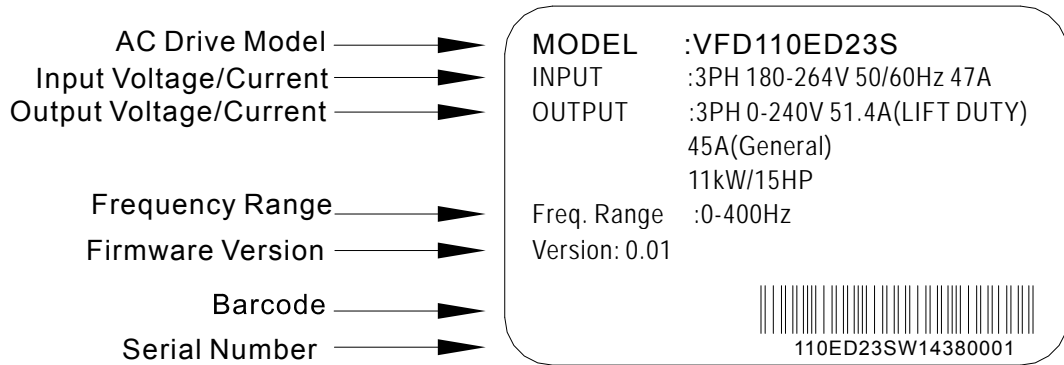

1-3 Model Name

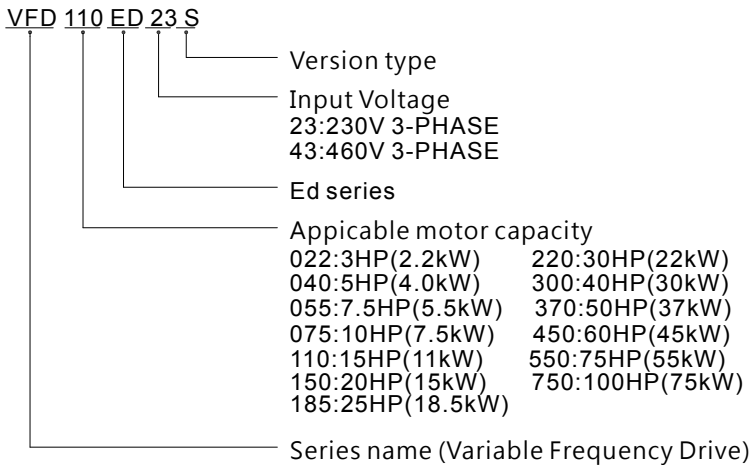

1-4 Serial Number

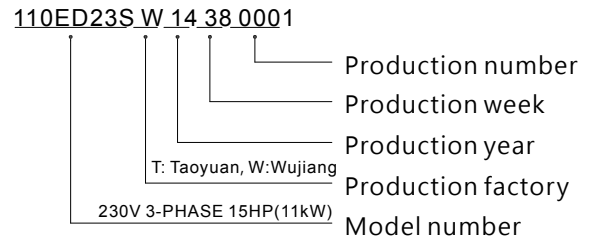

1-5 RFI Switch

The AC motor drive may emit the electrical noise. The RFI switch is used to suppress the interference (Radio Frequency Interference) on the power line. The RFI Switch of Frame C, D, E are at similar position (Frame B doesn't have a RFI Switch). Open the top cover to remove the RFI switch as shown in the image below.

Frame E

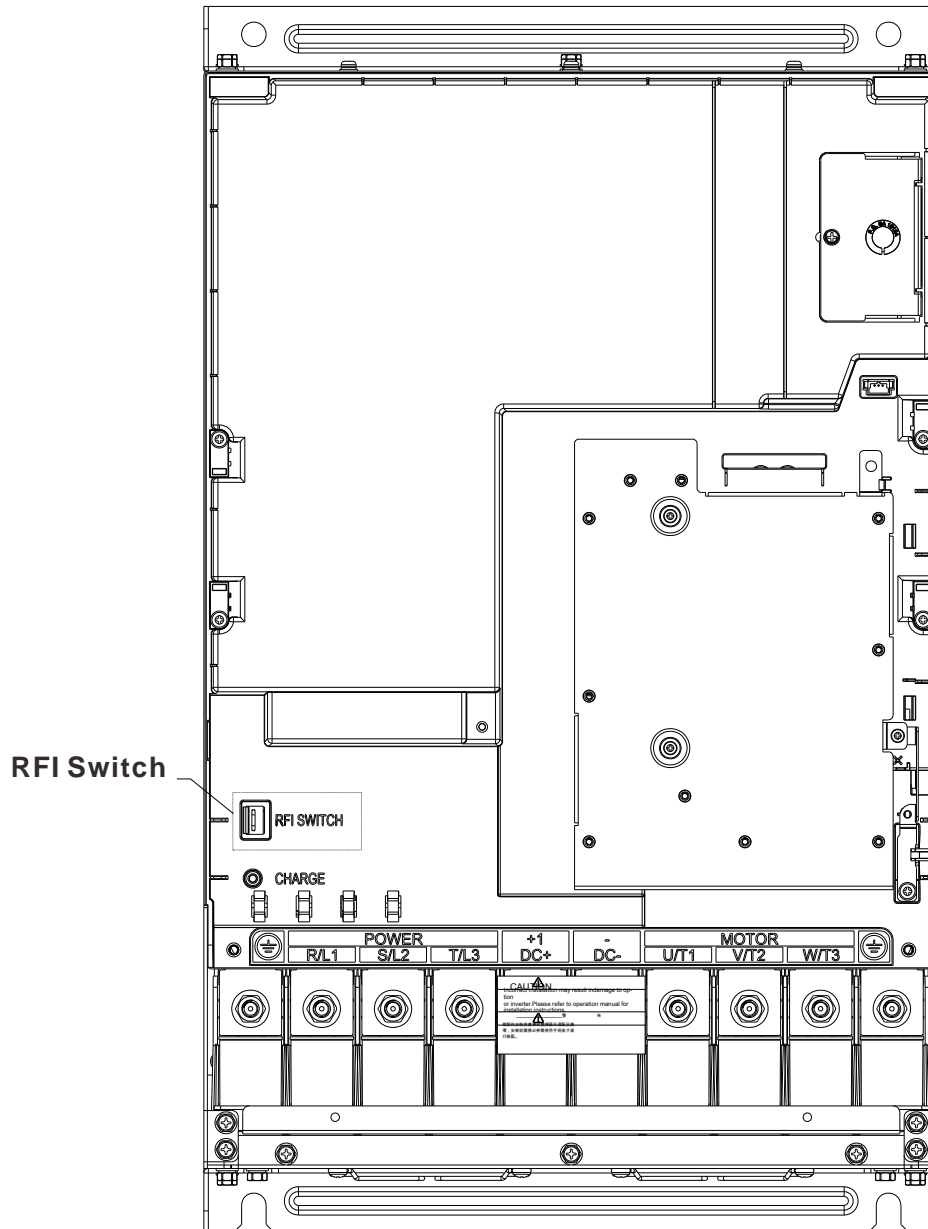

Isolating main power from ground:

When the power distribution system of the Power Regenerative Unit is a floating ground system (IT) or an asymmetric ground system (TN), the RFI short-circuit cable must be cut off. Cutting off the short-circuit cable also cuts off the internal RFI capacitor (filter capacitor) between the system's frame and the central circuits to avoid damaging the central circuits and (according to IEC 61800-3) reduce the ground leakage current.

Important points regarding ground connection

- ☑ To ensure the safety of personnel, proper operation, and to reduce electromagnetic radiation, the Power Regenerative Unit must be properly grounded during installation.
- ☑ The diameter of the cables must meet the size specified by safety regulations.
- ☑ The shielded cable must be connected to the ground of the Power Regenerative Unit to meet safety regulations.
- ☑ The shielded cable can only be used as the ground for equipment when the aforementioned points are met.
- ☑ When installing multiple sets of Power Regenerative Units, do not connect the grounds of the Power Regenerative Units in series. As shown below

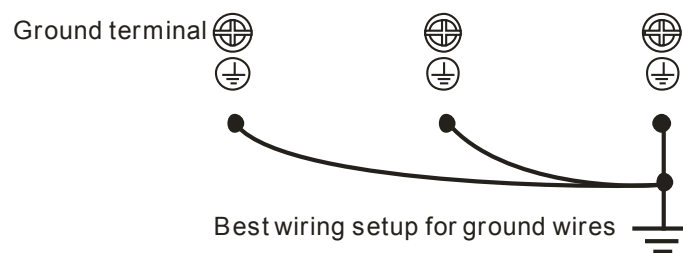

Pay particular attention to the following points:

- ☑ After turning on the main power, do not cut the RFI short-circuit cable while the power is on.
- ☑ Make sure the main power is turned off before cutting the RFI short-circuit cable.
- ☑ Cutting the RFI short-circuit cable will also cut off the conductivity of the capacitor. Gap discharge may occur once the transient voltage exceeds 1000V.

If the RFI short-circuit cable is cut, there will no longer be reliable electrical isolation. In other words, all controlled input and outputs can only be seen as low-voltage terminals with basic electrical isolation. Also, when the internal RFI capacitor is cut off, the Power Regenerative Unit will no longer be electromagnetic compatible.

- ☑ The RFI short-circuit cable may not be cut off if the main power is a grounded power system.
- ☑ The RFI short-circuit cable may not be cut off while conducting high voltage tests. When conducting a high voltage test to the entire facility, the main power and the motor must be disconnected if leakage current is too high.

Floating Ground System(IT Systems)

A floating ground system is also called IT system, ungrounded system, or high impedance/resistance (greater than 30Ω) grounding system.

- ☑ Disconnect the ground cable from the internal EMC filter.
- ☑ In situations where EMC is required, check whether there is excess electromagnetic radiation affecting nearby low-voltage circuits. In some situations, the adapter and cable naturally provide enough suppression. If in doubt, install an extra electrostatic shielded cable on the power supply side between the main circuit and the control terminals to increase security.
- ☑ Do not install an external RFI/EMC filter, the EMC filter will pass through a filter capacitor, thus connecting power input to ground. This is very dangerous and can easily damage the Power Regenerative Unit.

Asymmetric Ground System (Corner Grounded TN Systems)

Caution: Do not cut the RFI short-circuit cable while the input terminal of the Power Regenerative Unit carries power.

In the following four situations, the RFI short-circuit cable must be cut off. This is to prevent the system from grounding through the RFI capacitor, damaging the Power Regenerative Unit.

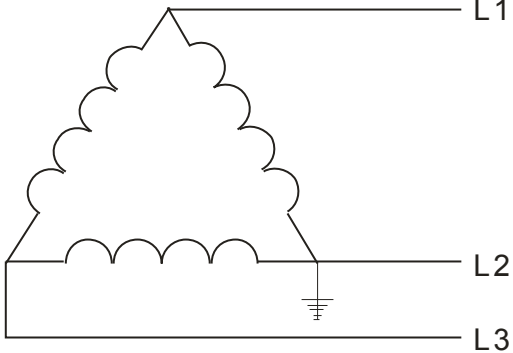
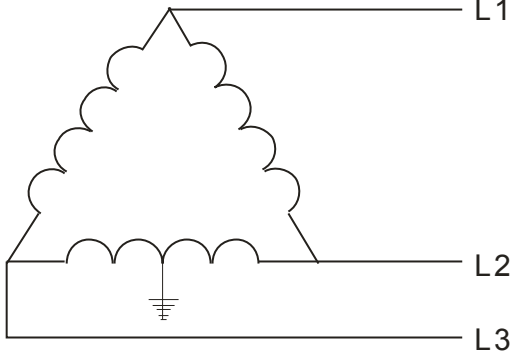
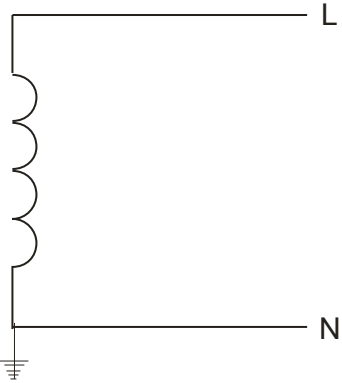
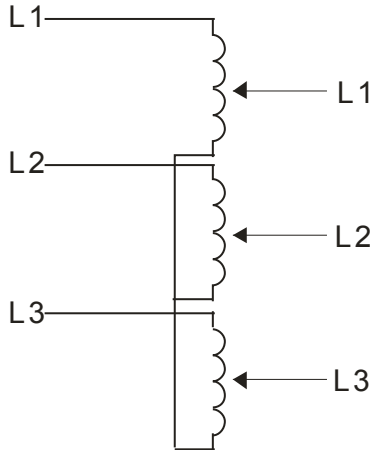
RFI short-circuit cable must be cut off	
<p>1. Grounding at a corner in a triangle configuration</p> 	<p>2. Grounding at a midpoint in a polygonal configuration</p> 
<p>3. Grounding at one end in a single-phase configuration</p> 	<p>4. No stable neutral grounding in a three-phase autotransformer configuration</p> 

Use RFI short-circuit

Internal grounding through RFI capacitor, which reduces electromagnetic radiation. In a situation with higher requirements for electromagnetic compatibility, and using a symmetrical grounding power system, an EMC filter can be installed. For example, the diagram on the right is a symmetrical grounding power system.

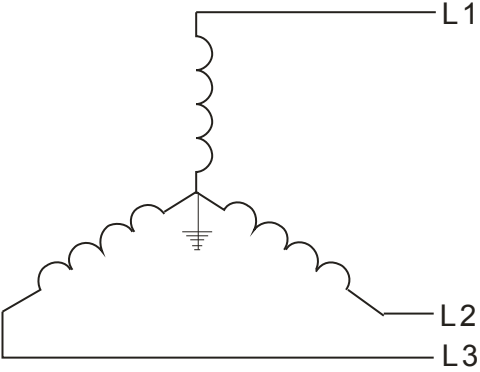

1-6 Dimensions

Frame B

VFD022ED21S, VFD037ED21S, VFD040ED23S/43S;

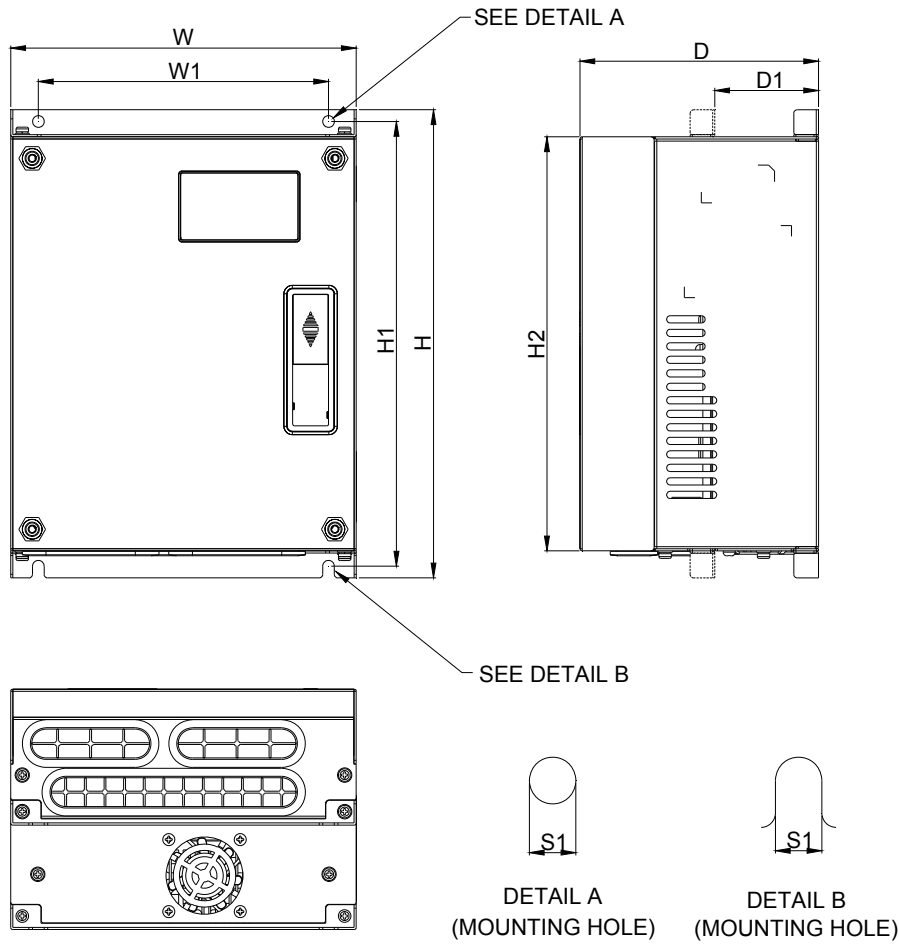

DIMENSIONAL

UNIT:mm[inch]

FRAME	W	W1	H	H1	H2	D	D1*	S1
B	193.5 [7.60]	162.5 [6.39]	260.0 [10.22]	247.0 [9.71]	230.0 [9.04]	133.5 [5.25]	58.0 [2.28]	6.5 [0.26]

*D1: This dimension is for flange mounting application reference.

Frame C

VFD055ED23S/43S, VFD075ED23S/43S, VFD110ED23S/43S, VFD150ED43S, VFD185ED43S;

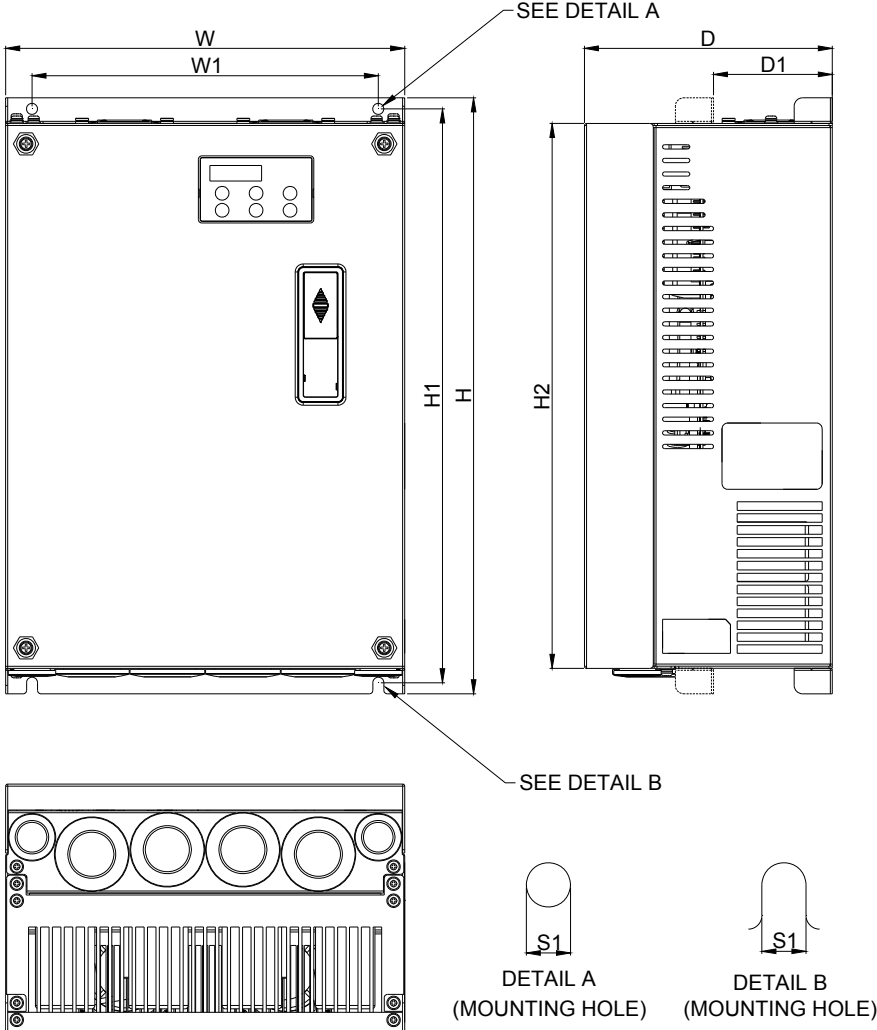

DIMENSIONAL

UNIT:mm[inch]

FRAME	W	W1	H	H1	H2	D	D1*	S1
C	235.0 [9.25]	204.0 [8.03]	350.0 [13.78]	337.0 [13.27]	320.0 [15.60]	146.0 [5.75]	70.0 [2.76]	6.5 [0.26]

*D1: This dimension is for flange mounting application reference.

Frame D

VFD150ED23S, VFD185ED23S, VFD220ED23S/43S, VFD300ED43S;

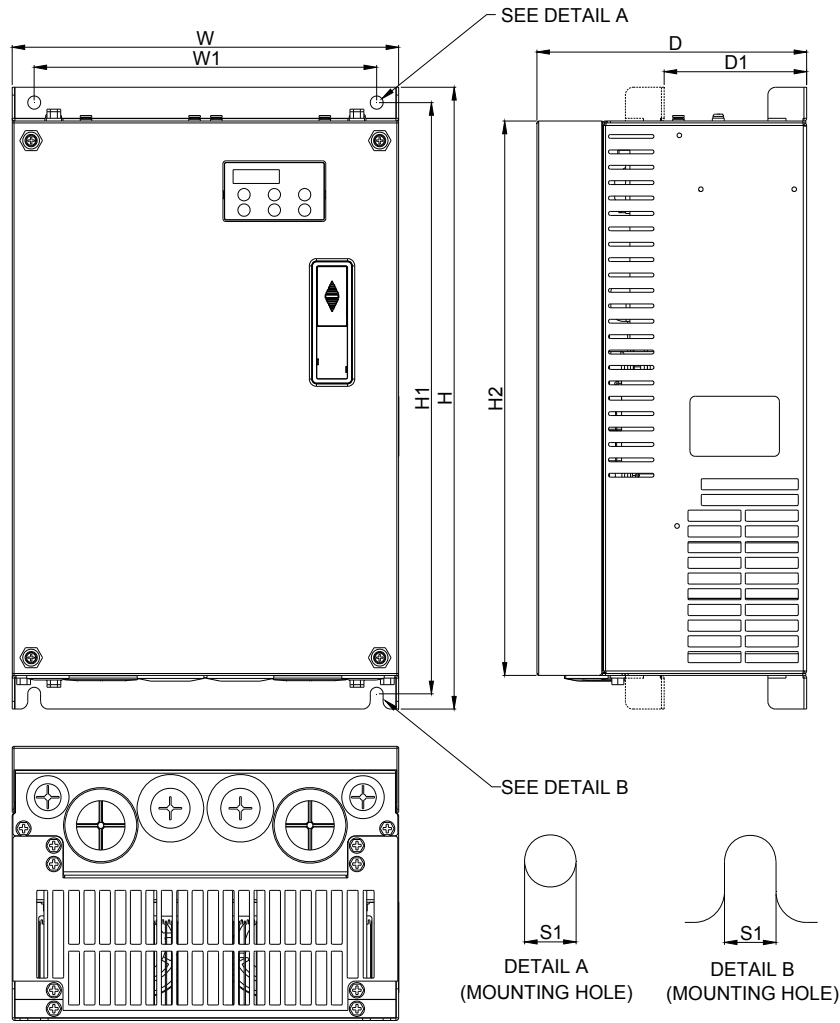

DIMENSIONAL

UNIT:mm[inch]

FRAME	W	W1	H	H1	H2	D	D1*	S1
D	255.0 [10.04]	226.0 [8.90]	403.8 [15.90]	384.0 [15.12]	360.0 [14.17]	178.0 [7.01]	94.0 [3.70]	8.5 [0.33]

*D1: This dimension is for flange mounting application reference.

Frame E

VFD300ED23S, VFD370ED23S/43S, VFD450ED43S, VFD550ED43S, VFD750ED43S;

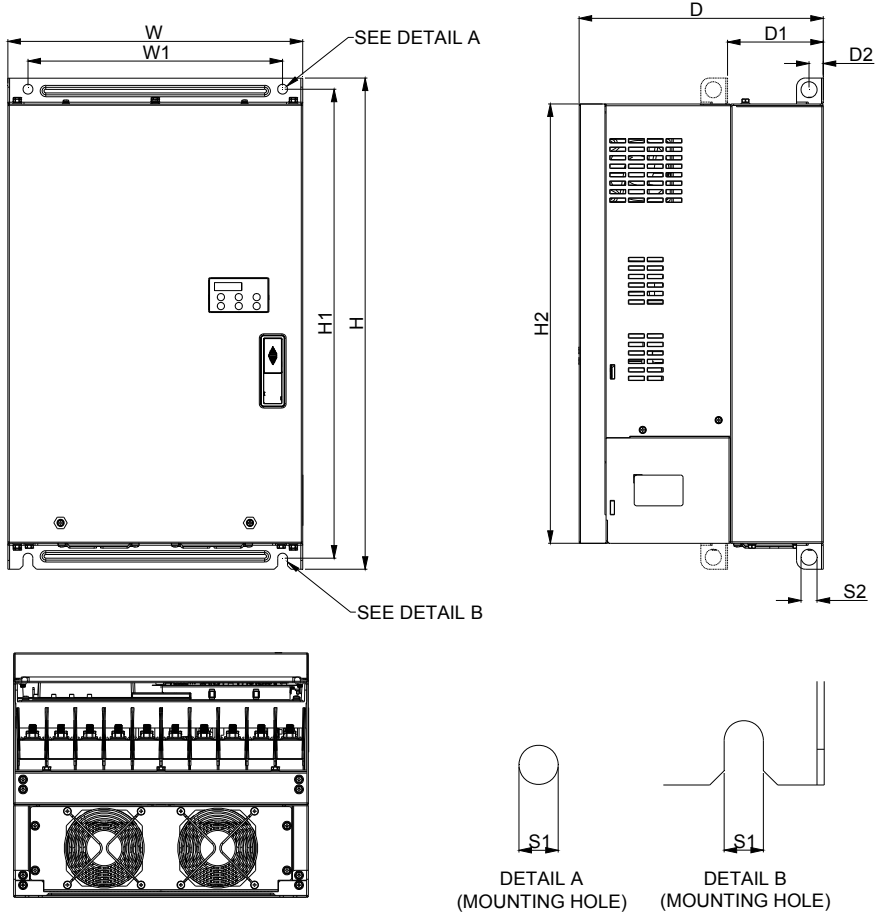

DIMENSIONAL

UNIT:mm[inch]

FRAME	W	W1	H	H1	H2	D	D1*	D2	S1	S2
E	330.0 [12.99]	285.0 [11.22]	550.0 [21.65]	525.0 [20.67]	492.0 [19.37]	273.4 [10.76]	107.2 [4.22]	16.0 [0.63]	11.0 [0.43]	18.0 [0.71]

*D1: This dimension is for flange mounting application reference.

Built-in Digital Keypad
KPED-LE01

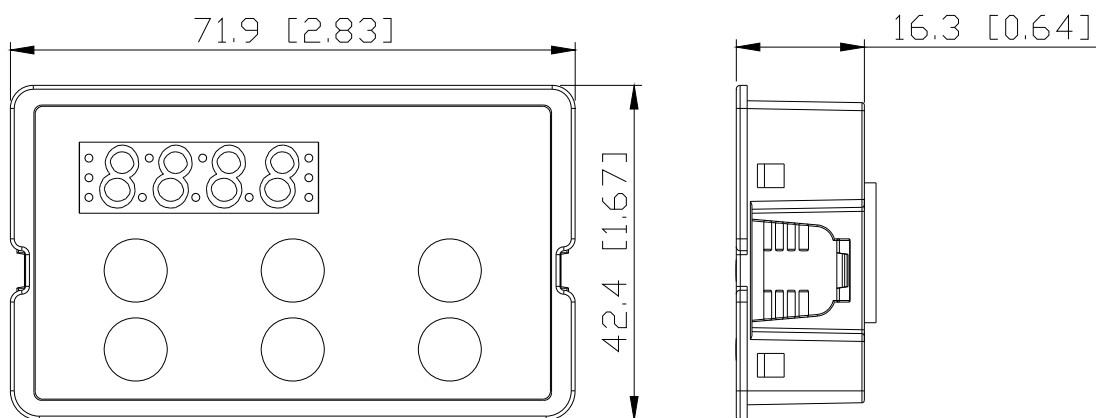

02 Installation

2-1 Minimum Mounting Clearance and Installation

NOTE

- ☑ Prevent fiber particles, scraps of paper, shredded wood saw dust, metal particles, etc. from adhering to the heat sink
- ☑ Install the AC motor drive in a metal cabinet. When installing one drive below another one, use a metal separation between the AC motor drives to prevent mutual heating and to prevent the risk of fire accident.
- ☑ Install the AC motor drive in Pollution Degree 2 environments only: normally only nonconductive pollution occurs and temporary conductivity caused by condensation is expected.

The image below is for reference only.

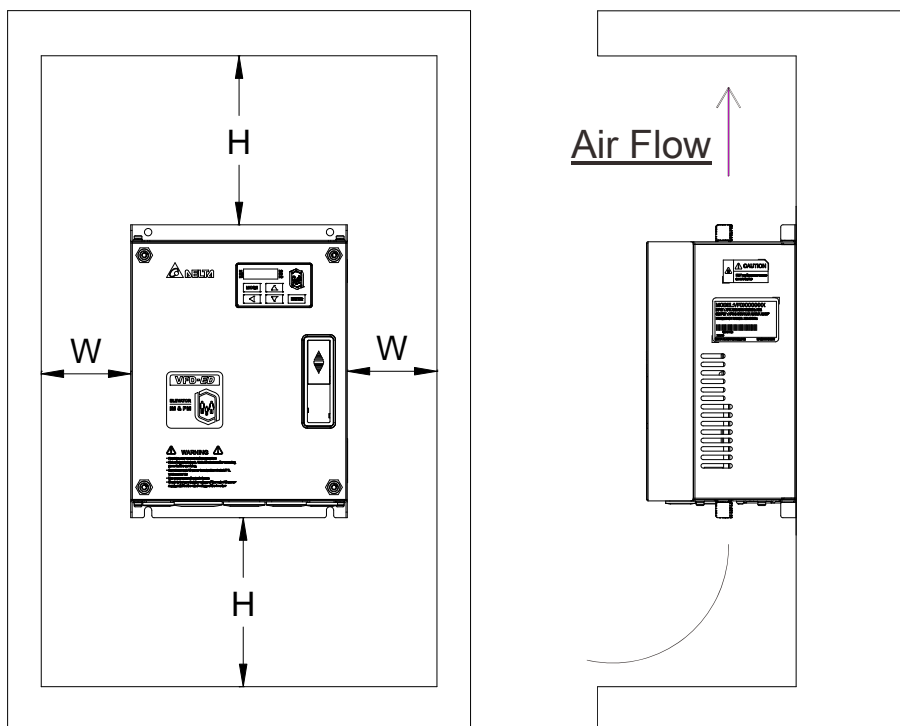

2-2 Minimum mounting clearance

Horsepower	Width	Height
	mm (inch)	mm (inch)
3-5HP	50 (2)	150 (6)
7.5-20HP	75 (3)	175 (7)
25-30HP	75 (3)	200 (8)

Frame	Capacity	Model No.
B	3.0-5.0HP (2.2-4kW)	VFD022ED21S, VFD037ED21S, VFD040ED23S/43S
C	7.5-15HP (5.5-11kW)	VFD055ED23S/43S, VFD075ED23S/43S, VFD110ED23S/43S, VFD150ED43S, VFD185ED43S
D	20-40HP (15-30kW)	VFD150ED23S, VFD185ED23S, VFD220ED23S/43S VFD300ED43S
E	40-100HP (30-75kW)	VFD300ED23S, VFD370ED23S/43S, VFD450ED43S, VFD550ED43S, VFD750ED43S

NOTE

The minimum mounting clearances stated in the table above applies to AC motor drives frame B,C,D and E. A drive which fails to follow the minimum mounting clearances may cause the fan to malfunction and heat dissipation problem.

Model No.	Air flow rate for cooling						Power Dissipation AC motor drive		
	Flow Rate(cfm)			Flow Rate(m3/hr)			Power Dissipation		
	External	Internal	Total	External	Internal	Total	Loss External (Heat Sink)	Internal	Total
VFD022ED21S	13.7	-	13.7	23.3	-	23.3	60	36	96
VFD037ED21S	23.9	-	23.9	40.7	-	40.7	84	46	130
VFD040ED23S	23.9	-	23.9	40.7	-	40.7	133	49	182
VFD055ED23S	48.5	-	48.5	82.4	-	82.4	212	67	279
VFD075ED23S	48.5	-	48.5	82.4	-	82.4	292	86	379
VFD110ED23S	47.9	-	47.9	81.4	-	81.4	355	121	476
VFD150ED23S	64.6	-	64.6	109.8	-	109.8	490	161	651
VFD185ED23S	102.3	-	102.3	173.8	-	173.8	638	184	822
VFD220ED23S	102.8	-	102.8	174.7	-	174.7	723	217	939
VFD300ED23S	179	30	209	304	51	355	932	186	1118
VFD370ED23S	179	30	209	304	51	355	1112	222	1334
VFD040ED43S	13.7	-	13.7	23.3	-	23.3	123	42	165
VFD055ED43S	48.5	-	48.5	82.4	-	82.4	185	55	240
VFD075ED43S	48.5	-	48.5	82.4	-	82.4	249	71	320
VFD110ED43S	47.9	-	47.9	81.4	-	81.4	337	94	431

VFD150ED43S	46.1	-	46.1	78.4	-	78.4	302	123	425
VFD185ED43S	46.1	-	46.1	78.4	-	78.4	391	139	529
VFD220ED43S	102.8	-	102.8	174.7	-	174.7	642	141	783
VFD300ED43S	83.7	-	83.7	142.2	-	142.2	839	180	1019
VFD370ED43S	179	30	209	304	51	355	803	252	1055
VFD450ED43S	179	30	209	304	51	355	1014	270	1284
VFD550ED43S	179	30	209	304	51	355	1244	275	1519
VFD750ED43S	186	30	216	316	51	367	1541	338	1878

Derating Capacity of Carrier Frequency (Fc):

Frame	B	C	D	E	E
Fc(kHz)	2.2~4 kW	5.5~11 kW	15~22 kW	30~45 kW	55~75kW
0	100%	100%	100%	100%	100%
1	100%	100%	100%	100%	100%
2	100%	100%	100%	100%	100%
3	100%	100%	100%	100%	100%
4	100%	100%	100%	100%	100%
5	100%	100%	100%	100%	100%
6	100%	100%	100%	100%	100%
7	100%	100%	100%	90.73%	-
8	100%	100%	100%	82.20%	-
9	94.24%	100%	92.32%	74.31%	-
10	88.92%	100%	85.21%	-	-
11	82.54%	95.35%	78.63%	-	-
12	78.08%	91.02%	72.53%	-	-
13	73.95%	86.98%	66.87%	-	-
14	70.14%	84.14%	61.62%	-	-
15	66.61%	80.67%	56.74%	-	-

Derating Curve of Carrier Frequency (Fc):

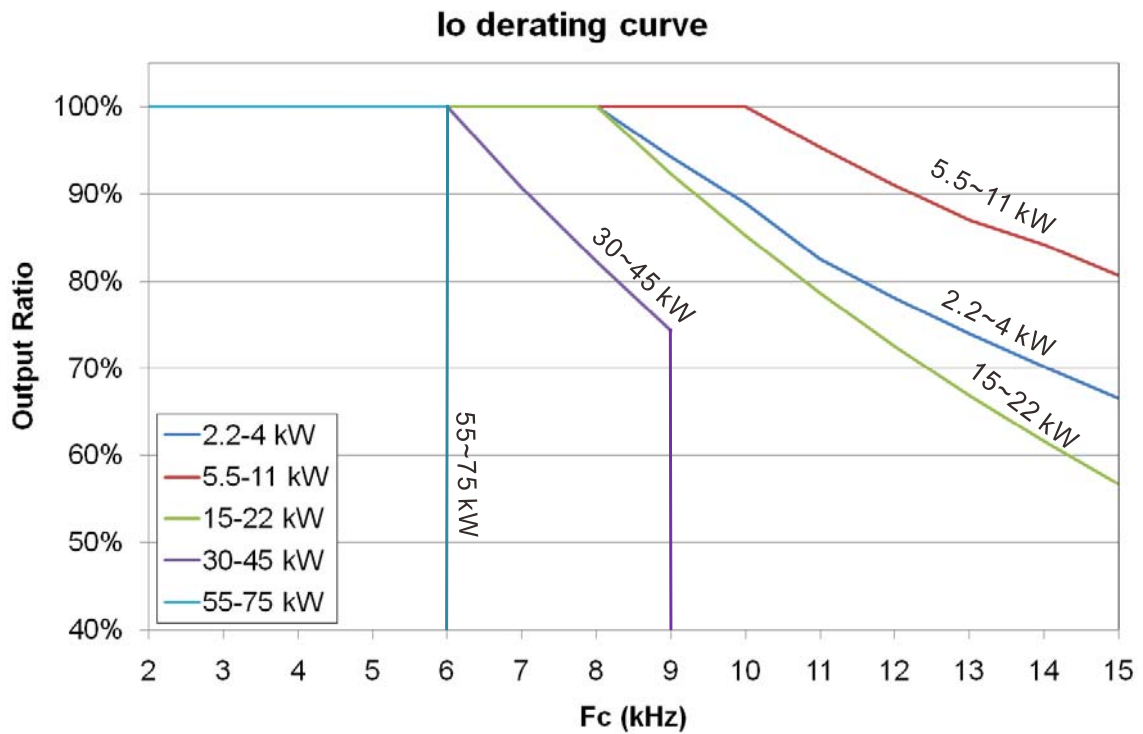

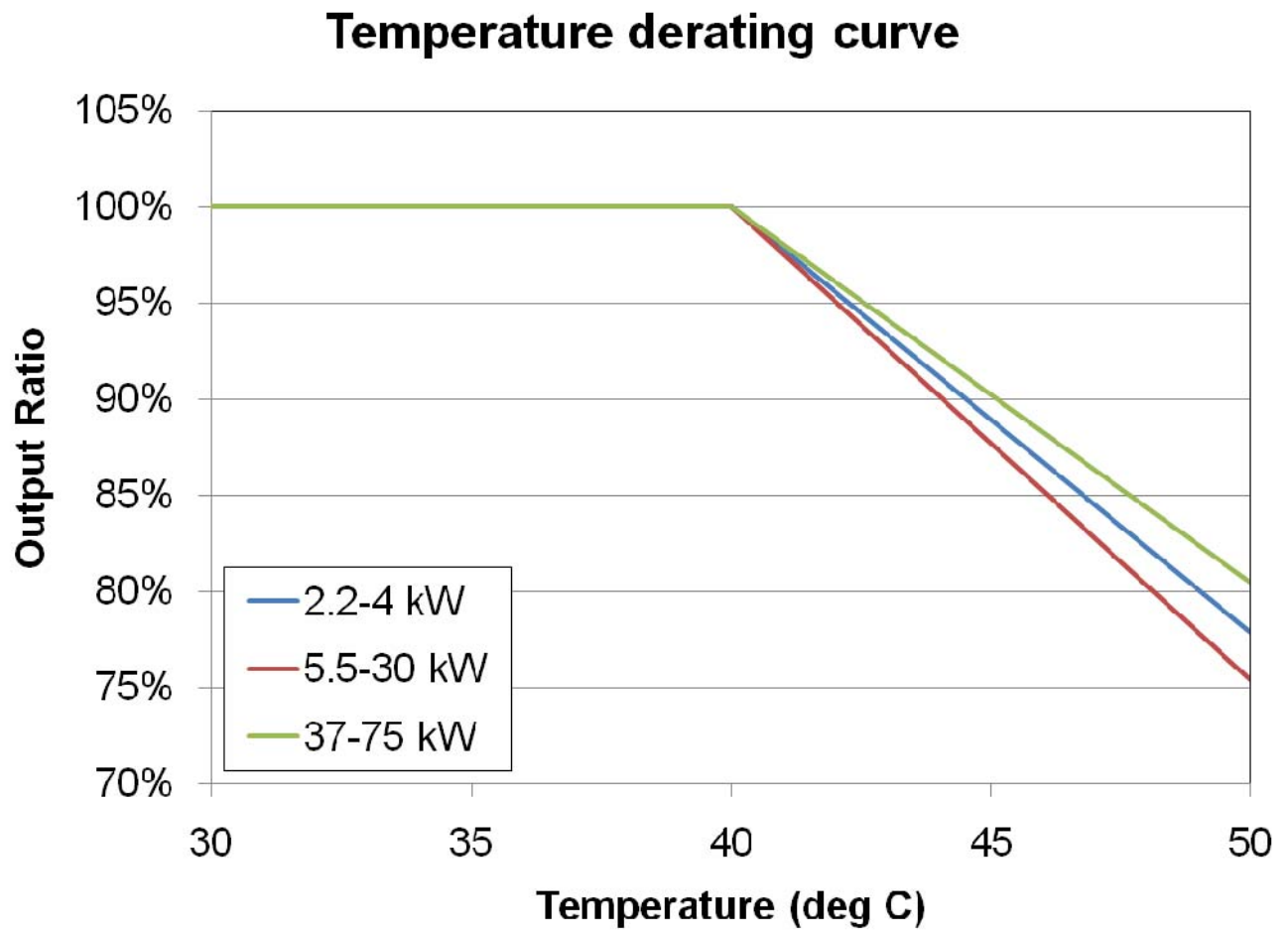
Ambient Temperature Derating Curve:

03 Wiring

After removing the front cover, examine if the power and control terminals are clearly noted. Read following precautions before wiring.

- ☑ Make sure that power is only applied to the R/L1, S/L2, T/L3 terminals. Failure to comply may result in damage to the equipments. The voltage and current should lie within the range as indicated on the nameplate (Chapter 1-1).
- ☑ All the units must be grounded directly to a common ground terminal to prevent lightning strike or electric shock.
- ☑ Make sure to fasten the screw of the main circuit terminals to prevent sparks which is made by the loose screws due to vibration



- ☑ It is crucial to turn off the AC motor drive power before any wiring installation are made. A charge may still remain in the DC bus capacitors with hazardous voltages even if the power has been turned off therefore it is suggested for users to measure the remaining voltage before wiring. For your personnel safety, please do not perform any wiring before the voltage drops to a safe level < 25 Vdc. Wiring installation with remaninig voltage condition may caus sparks and short circuit.
- ☑ Only qualified personnel familiar with AC motor drives is allowed to perform installation, wiring and commissioning. Make sure the power is turned off before wiring to prevent electric shock.



- ☑ When wiring, please choose the wires with specification that complys with local regulation for your personnel safety.
- ☑ Check following items after finishing the wiring:
 1. Are all connections correct?
 2. Any loosen wires?
 1. Any short-circuits between the terminals or to ground?

3-1 Wiring

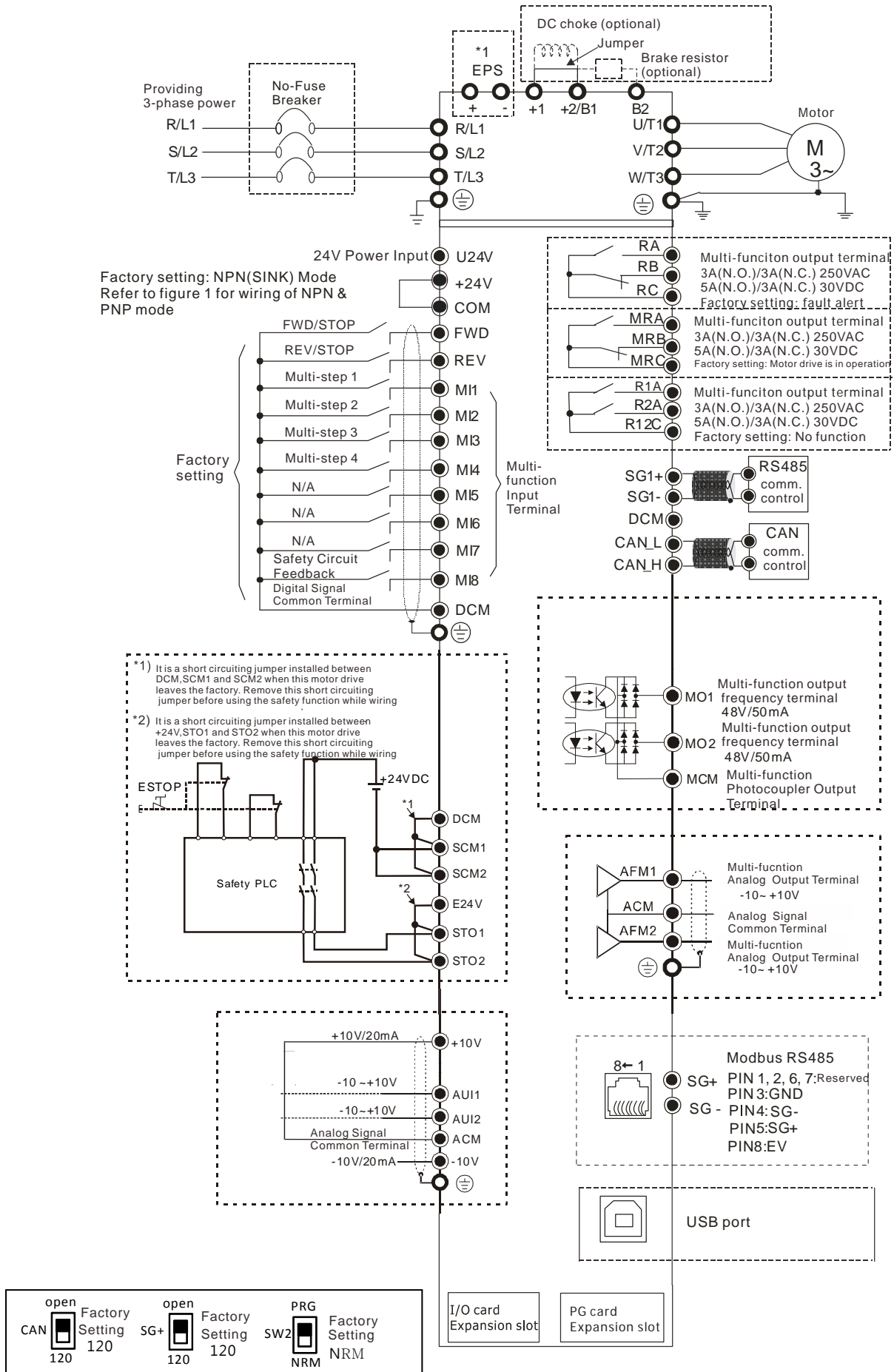
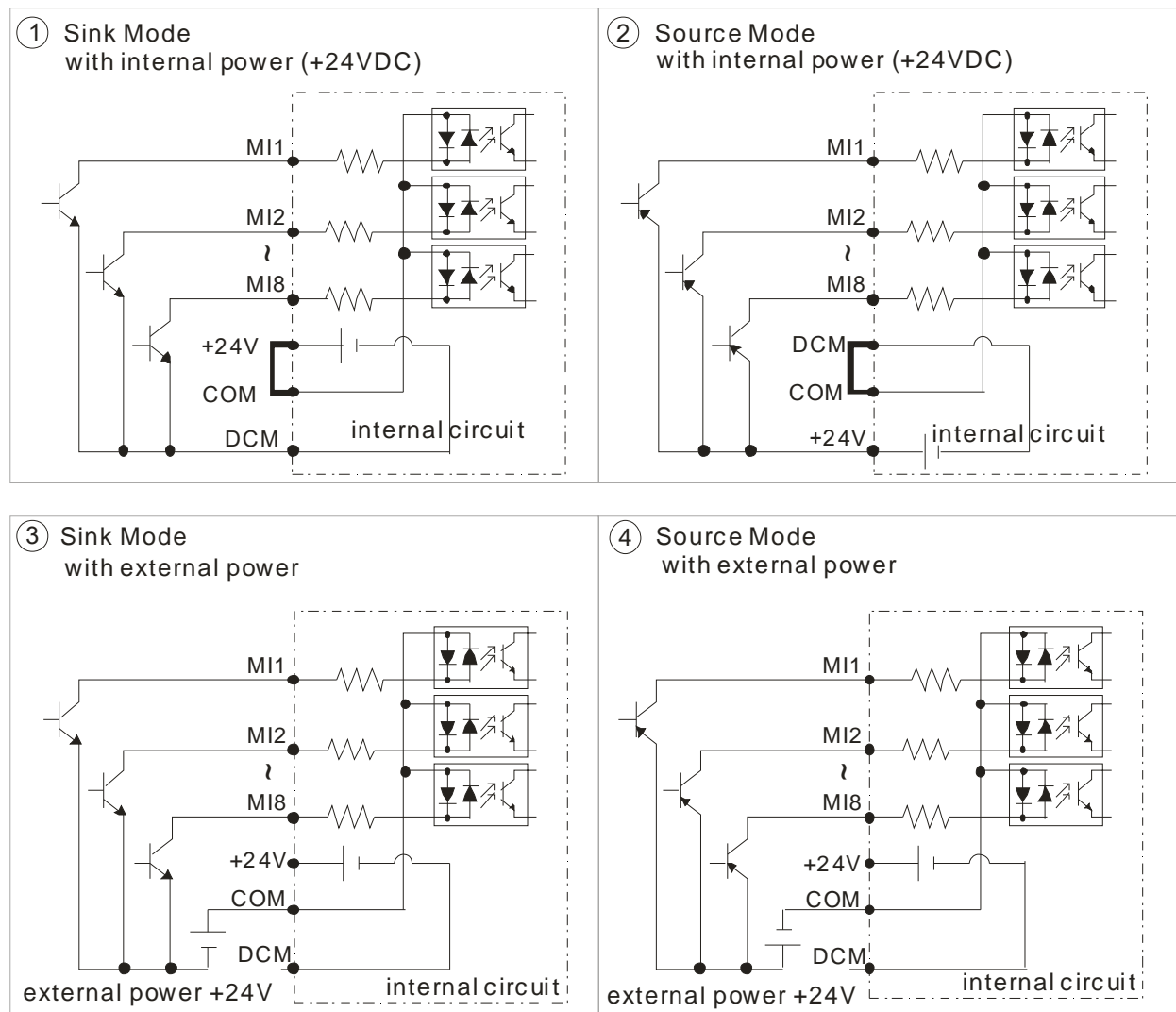
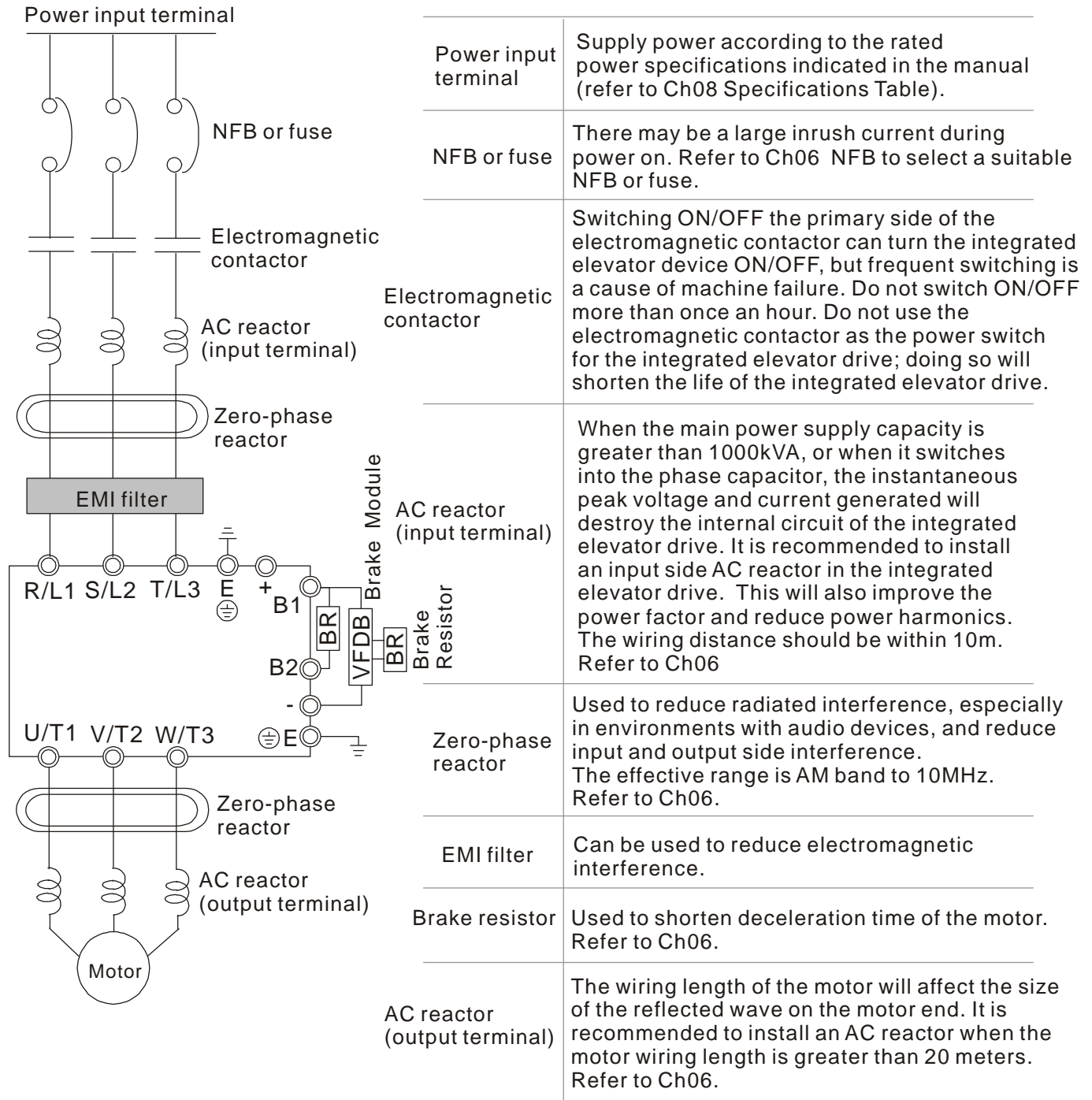

Figure 01

Switching between two modes: SINK(NPN) /SOURCE(PNP)



3-2 System Wiring Diagram



04 Main Circuit Terminals

4-1 Main Circuit Diagram

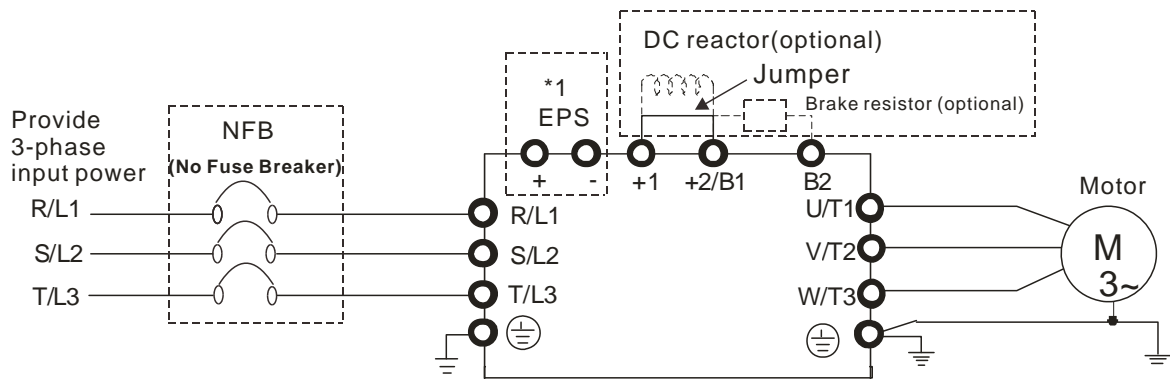

Terminal Symbol	Explanation of Terminal Function
EPS (+, -)	Backup power/ Emergency power connection terminal.
R/L1, S/L2, T/L3	AC line input terminals 3-phase.
U/T1, V/T2, W/T3	AC drive output terminals for connecting 3-phase induction motor.
+1, +2/B1	Connections for DC reactor to improve the power factor. Remove the jumper before installing a DC reactor. (Frame E has a DC reactor built-in.).
+2/B1, B2	Connections for brake resistor (optional).
⊕ E	Earth connection, to comply with local regulations.



Main input power terminals:

- ☑ Do not connect 3-phase model to one-phase power. R/L1, S/L2 and T/L3 has no phase-sequence requirement, it can be used upon random selection.
- ☑ A NFB must be installed between the 3-phase power input terminals and the main circuit terminals (R/L1, S/L2, T/L3). It is recommended to add a magnetic contactor (MC) to the power input wiring to cut off power quickly and reduce malfunction when activating the protection function of the AC motor drive. Both ends of the MC should have an R-C surge absorber.
- ☑ Fasten the screws in the main circuit terminal to prevent sparks condition made by the loose screws due to vibration.
- ☑ Use voltage and current within the specification in Chapter 8.
- ☑ When using a general GFCI (Ground Fault Circuit Interrupter), select a current sensor with sensitivity of 200mA or above and not less than 0.1-second operation time to avoid nuisance tripping. When choosing a GFCI designed for the AC motor drive, choose a current sensor with sensitivity of 30mA or above.
- ☑ Use the shield wire or tube for the power wiring and ground the two ends of the shield wire or tube.

- ☑ Do NOT run/stop AC motor drives by turning the power ON/OFF. Run/stop AC motor drives by sending RUN/STOP command via control terminals or keypad. If you still need to run/stop AC motor drives by turning power ON/OFF, it is recommended to do so only ONCE per hour

Output terminals of the main circuit:

- ☑ When it is necessary to install a filter at the output side of terminals U/T1, V/T2, W/T3 on the AC motor drive. Use inductance filter. Do not use phase-compensation capacitors or L-C (Inductance-Capacitance) or R-C (Resistance-Capacitance).
- ☑ DO NOT connect phase-compensation capacitors or surge absorbers at the output terminals of AC motor drives.
- ☑ Use well-insulated motors to prevent any electric leakage from motors.

Terminals [+1, +2] for connecting DC reactor. Terminals [+1, +2/B1] for connecting brake resistor.

- ☑ These terminals are to connect to a DC reactor to improve the power factor and reduce harmonics. At the factory setting, a jumper is connected to these terminals.. Remove that jumper before connecting to a DC reactor.

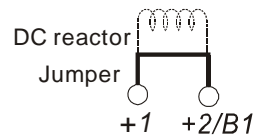

- ☑ Models above 22kW don't have a built-in brake resistor. To improve resistance ability, connect an external, optional brake resistor
- ☑ When not in use, leave terminals +2/B1, (–) open.
- ☑ Short-circuiting [B2] or [–] to [+2/B1] will damage the motor drive. Do NOT do that.

4-2 Main Circuit Terminals Specifications

Frame B

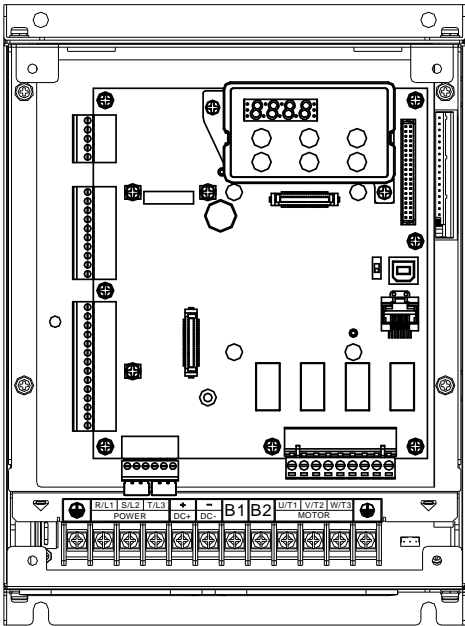

Main circuit terminals:

R/L1, S/L2, T/L3, U/T1, V/T2, WT3, + (DC+), - (DC-), B1, B2,

Models	Wire Gauge		Screw Size & Torque (? 0%)
	Max. Wire Gauge	Min. Wire Gauge	
VFD022ED21S	10AWG [5.3mm ²]	14AWG [2.1mm ²]	M4 18 kgf-cm (15.6 lbf-in) (1.7 Nm)
VFD040ED43S		12AWG [3.3mm ²]	
VFD037ED21S			
VFD040ED23S			

UL installations must use 600V, 75? wire. Use copper wire only.

NOTE:

- Figure 1 shows the terminal specification.
- Figure 2 shows the specification of insulated heat shrink tubing that comply with UL (600V, YDPU2).

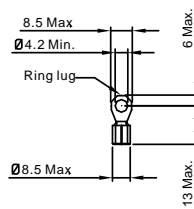

Figure 1

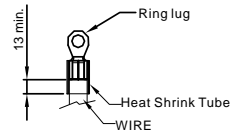
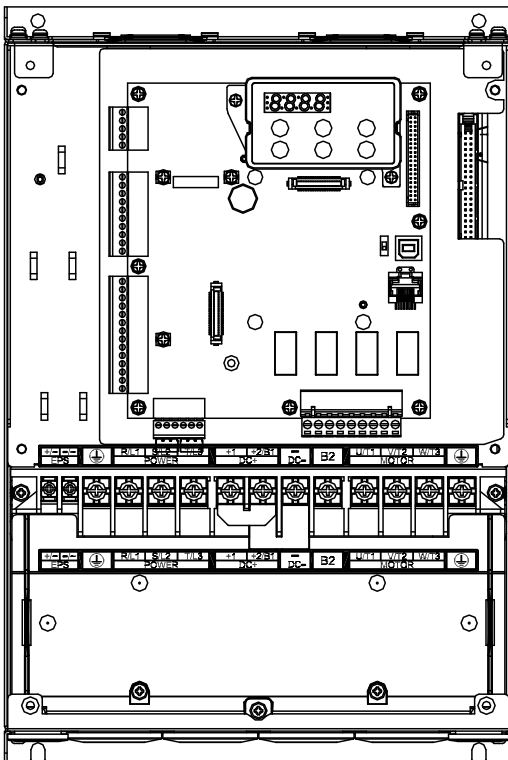

Figure 2

Frame C



Main circuit terminals:

R/L1, S/L2, T/L3, U/T1, V/T2, WT3, +1, +2/B1, -, B2,

Models	Wire Gauge		Screw Size & Torque (? 0%)
	Max. Wire Gauge	Min. Wire Gauge	
VFD055ED23S	6AWG [13.3mm ²]	10AWG [3.3mm ²]	M5 30 kgf-cm (26 lbf-in) (2.9 Nm)
VFD110ED43S		12AWG [3.3mm ²]	
VFD055ED43S			
VFD075ED43S		8AWG [8.4mm ²]	
VFD075ED23S			
VFD150ED43S			
VFD185ED43S		6AWG [13.3mm ²]	
VFD110ED23S			

UL installations must use 600V, 75? wire. Use copper wire only.

NOTE:

- Figure 1 shows the terminal specification.
- Figure 2 shows the specification of insulated heat shrink tubing that comply with UL (600V, YDPU2).

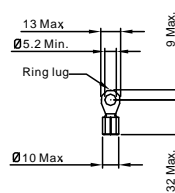

Figure 1

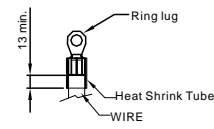
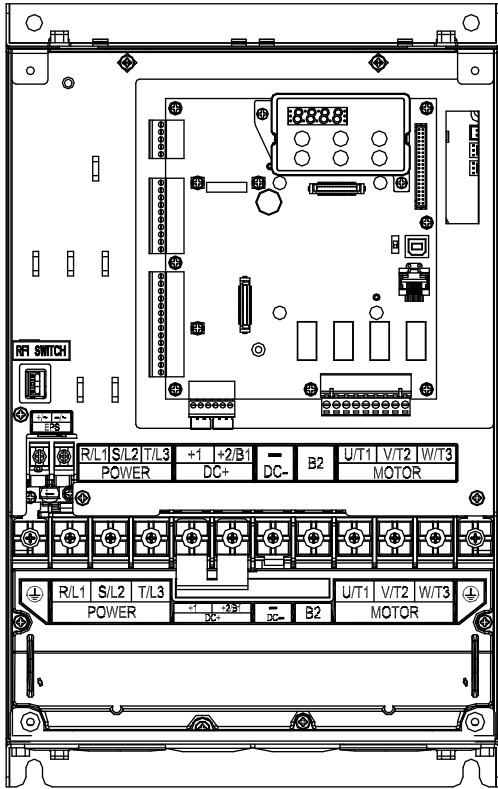

Figure 2

Frame D



Main circuit terminals:

R/L1, S/L2, T/L3, U/T1, V/T2, W/T3, +1, +2/B1, -, B2, ⚡

Models	Wire Gauge		Screw Size & Torque (? 0%)
	Max. Wire Gauge	Min. Wire Gauge	
VFD150ED23S	2AWG [33.6mm ²]	4AWG [21.1mm ²]	M6 50 kgf-cm (43.4 lbf-in) (4.9 Nm)
VFD300ED43S		3AWG [26.7mm ²]	
VFD185ED23S			
VFD220ED43S		2AWG [33.6mm ²]	
VFD220ED23S			

UL installations must use 600V, 75° wire. Use copper wire only.

NOTE:

1. Figure 1 shows the terminal specification.

2. Figure 2 shows the specification of insulated heat shrink tubing that comply with UL (600V, YDPU2).

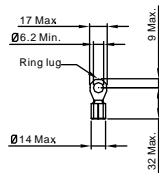

Figure 1

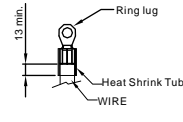
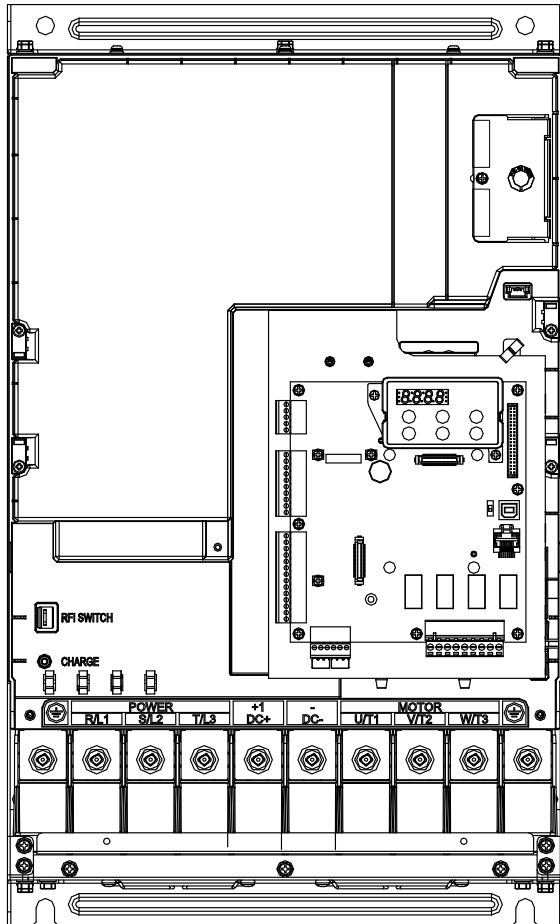

Figure 2

Frame E



Main circuit terminals:

R/L1, S/L2, T/L3, U/T1, V/T2, W/T3, +1(DC+), -(DC-), ⚡

Models	Wire Gauge		Screw Size & Torque (? 0%)
	Max. Wire Gauge	Min. Wire Gauge	
VFD370ED43S	300MCM [152mm ²]	1/0AWG [53.5mm ²]	M8 200 kgf-cm (173 lbf-in) (19.6 Nm)
VFD450ED43S		2/0AWG [67.4mm ²]	
VFD300ED23S		4/0AWG [107mm ²]	
VFD550ED43S			
VFD370ED23S		300MCM [152mm ²]	
VFD750ED43S			

UL installations must use 600V, 75° wire. Use copper wire only.

NOTE:

1. Figure 1 shows the terminal specification.

2. Figure 2 shows the specification of insulated heat shrink tubing that comply with UL (600V, YDPU2).

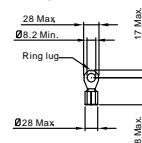

Figure 1

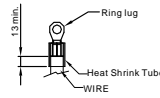

Figure 2

05 Control Terminals

Remove the top cover before wiring the multi-function input and output terminals

The motor drives' figures shown below are for reference only, the real motor drives may look different.

Remove the cover before wiring

Frame B, C & D:

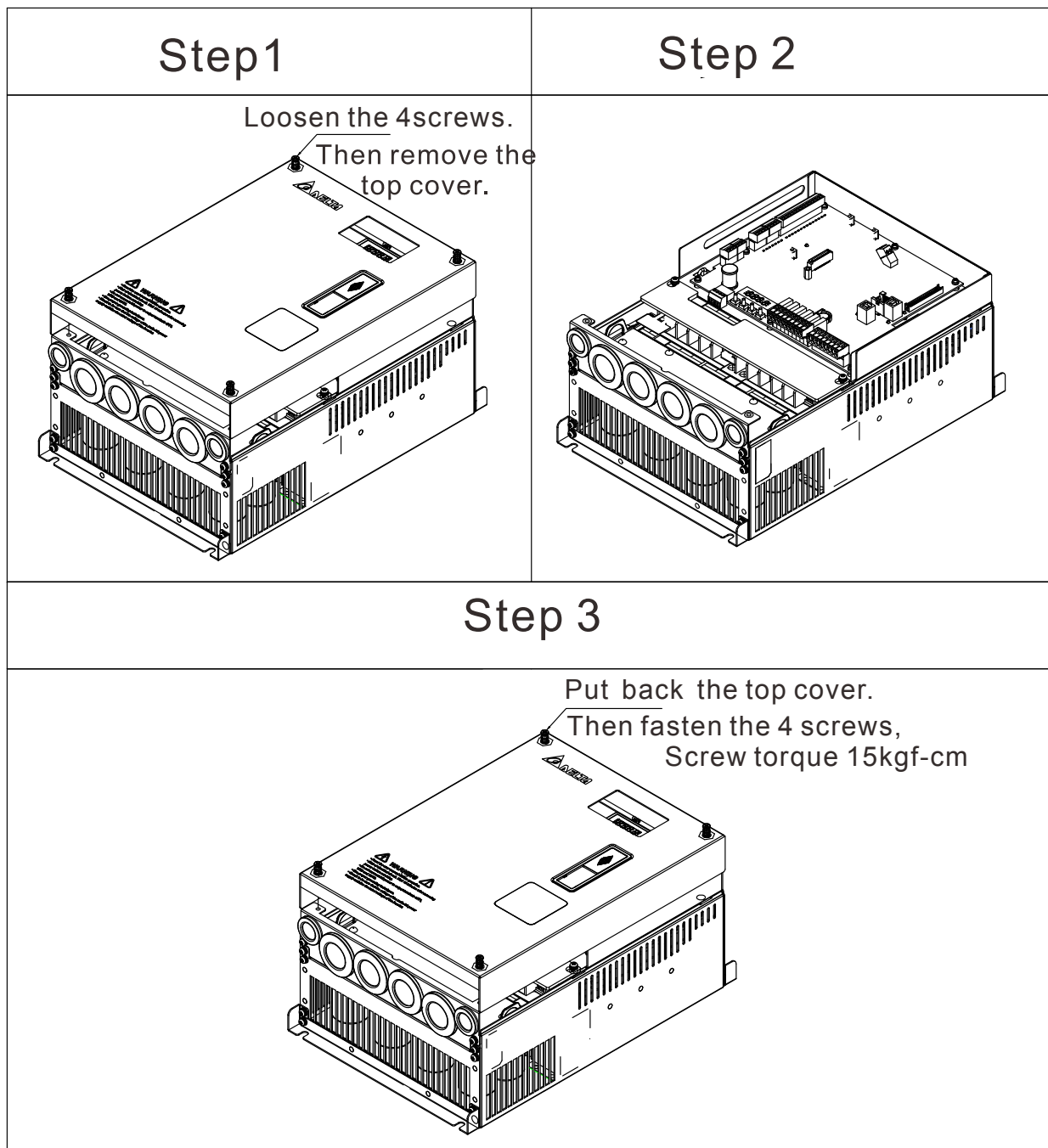

Frame E

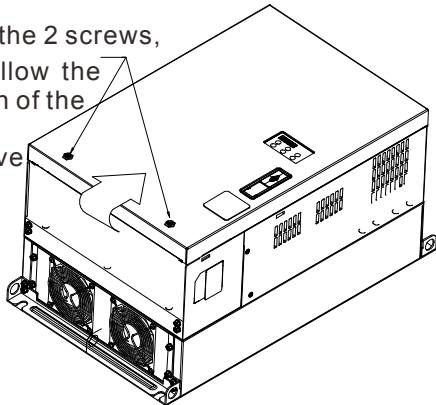
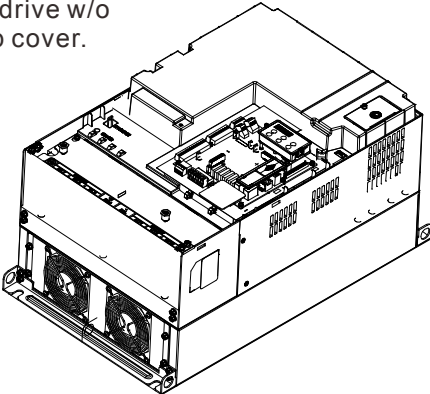
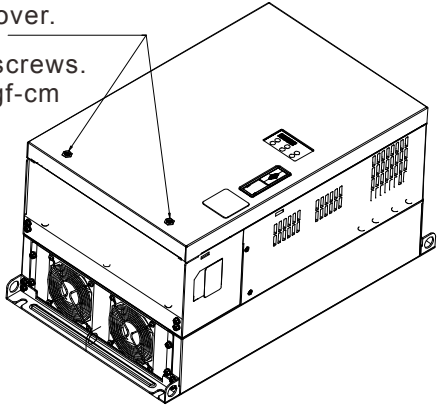
Step 1	Step 2
<p data-bbox="268 280 534 481">Loosen the 2 screws, Then follow the direction of the arrow to remove the top cover</p> 	<p data-bbox="865 257 1061 324">Motor drive w/o the top cover.</p> 
Step 3	
<p data-bbox="422 772 742 884">Put back the top cover. Then fasten the 2 screws. Screw torque: 15kgf-cm</p> 	

Specifications of the Control Terminal

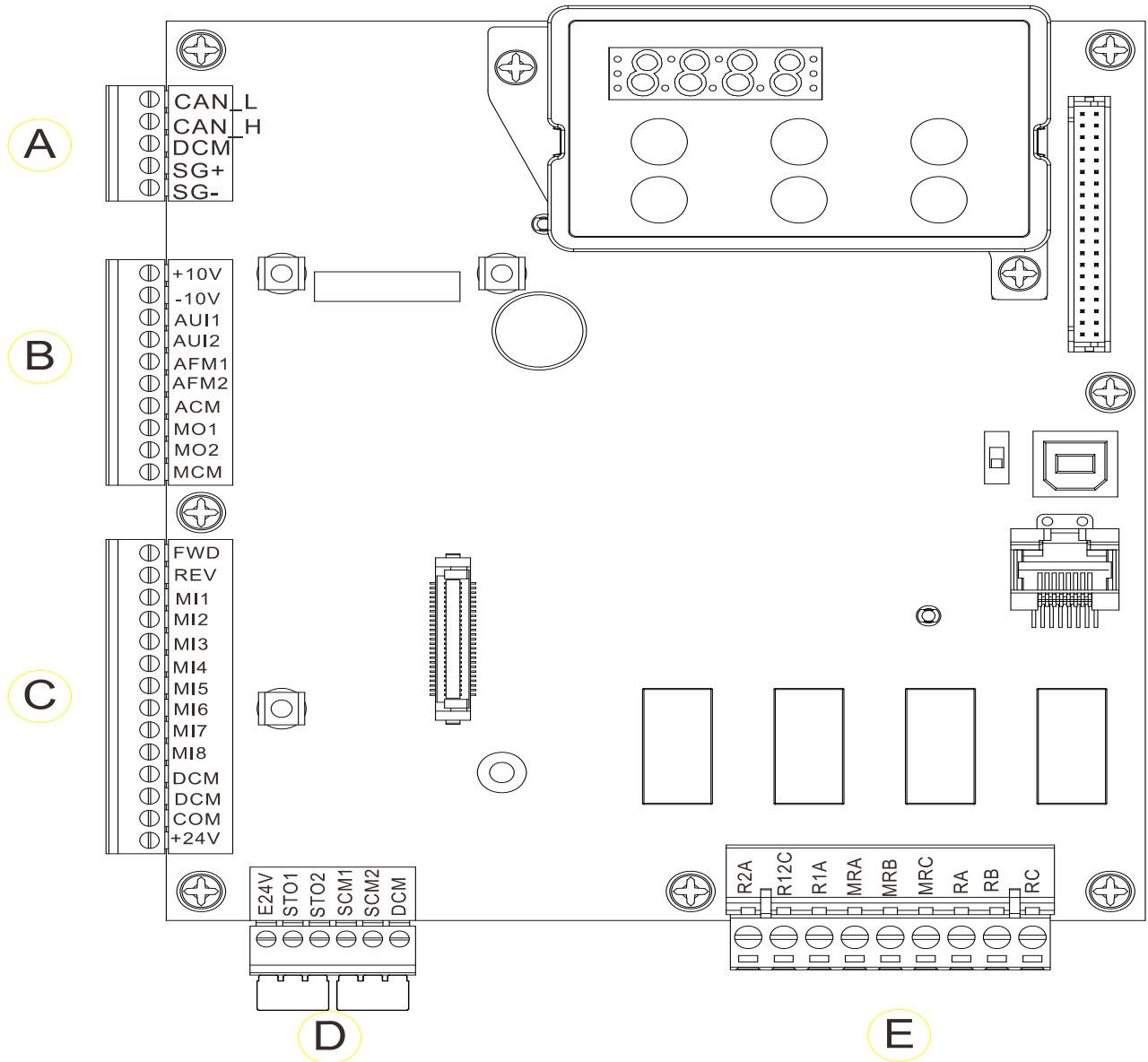

Control Circuit Terminal Sockets:

Terminal sockets A, B, C

Torque force: 2kg-cm [1.7lb-in.] (0.20Nm)

Wire gauge: 28~14AWG[0.08~2.07mm²]

Terminal socket D:

Torque force: 2kg-cm [1.7lb-in.] (0.20Nm)

Terminal socket E:

Torque force: 5.2kg-cm [4.5lb-in.] (0.51Nm)



Wire gauge: 28~12AWG[0.08~3.33mm²]

To comply with UL standards, copper wires which are able to sustain 600V, 75°C environment must be used in the installation.

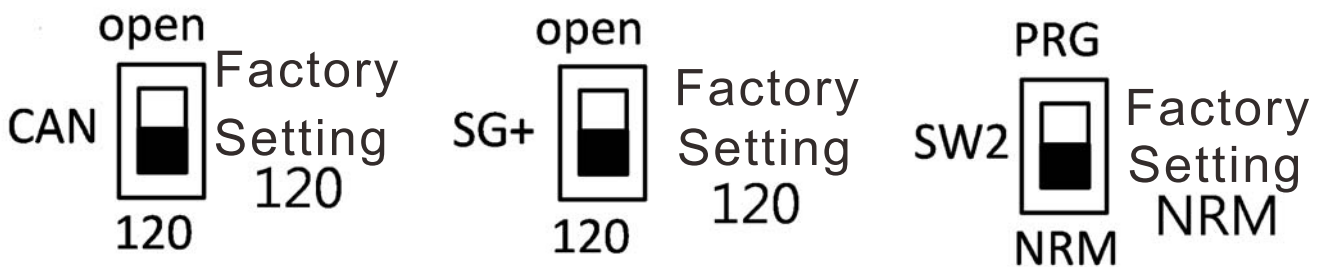
Control Board Switch

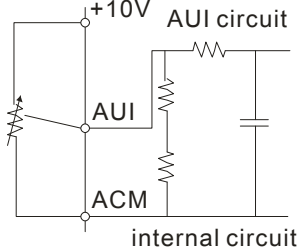

Terminals	Terminal Function	Factory Setting (NPN mode)
+24V/E24V	Digital control signal common terminal (Source)	+24V±5% 200mA
COM	Digital control signal common terminal (Sink)	Common terminal of multi-function input terminals
FWD	Forward-Stop command	FWD-DCM: ON= forward running OFF= deceleration to stop
REV	Reverse-Stop command	REV-DCM: ON= forward running OFF= deceleration to stop
MI1 ~ MI8	Multi-function input 1~8	Refer to parameters 02-01~02-08 to program the multi-function inputs MI1~MI8. Source mode: ON: the activation current is $6.5\text{mA} \geq 11\text{Vdc}$ OFF: cut-off voltage $10\mu\text{A} \leq 11\text{Vdc}$
DCM	Digital frequency signal common terminal	
SCM1		
SCM2	The factory setting is short-circuit.	
STO1	The factory setting is short-circuit.	
STO2	Power removal safety function for EN954-1 and IEC/EN61508 When STO1~SCM1, STO2~SCM2 are turned on, the activation current is $3.3\text{mA} \geq 11\text{Vdc}$.	
+10V	Potentiometer power supply	Power supply of analog frequency setting: +10Vdc 20mA
-10V	Potentiometer power supply	Power supply of analog frequency setting
AUI1	Analog voltage frequency input	Impedance: 20kΩ Range: -10~+10VDC=0~ Max. Output

AUI2		Frequency(Pr.01-00)
ACM	Analog signal common terminal control	Analog signal terminal
RA	Multi-function relay output A (N.O.)	<p>1. User-defined funcion</p> <p>2. Resistive Load 3A(N.O.)/3A(N.C.) 250VAC 5A(N.O.)/3A(N.C.) 30VDC (min. 5 VDC, 10 mA)</p> <p>To output different kinds of signal such as the motor drive is in operation, reaching the frequency, overload indication.</p>
RB	Multi-function relay output A (N.O.)	
RC	Multi-function relay output B (Error indication by factory setting)	
MRA	Multi-function output terminal (N.O.)	
MRB	Multi-function output terminal (N.O.)	
MRC	Multi-function output terminal (Operating Indication by factory setting)	
R1A	Multi-function output terminal A (N.O.)	
R2A	Multi-function output terminal A (N.O.)	
R12C	Multi-function output terminal (No function by factory setting)	
SG1+	Modbus RS-485	SG1+ switch: terminator 120 ohm (factory setting) / open
SG1-	Modbus RS-485	
CAN_L	CAN Bus	DIP Switch: terminator 120 ohm (factory setting)/ open
CAN_H	CAN Bus	
MO1	Multi-function output terminal 1 (photocoupler)	<p>The AC motor drive releases various monitoring signals, such as drive in operation, reaching frequency and overload indication via a transistor (open collector).</p> 
MO2	Multi-function output terminal 2 (photocoupler)	
MCM	Multi-function output common terminal (photocoupler)	

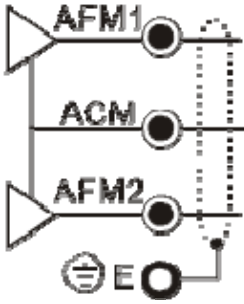
AFM1		<p>0~10V, Max. output current: 2mA, Max. load: 5kΩ -10~10V, Max. output current: 2mA, Max. load :5kΩ Output current 2mA max Resolution 0~10V corresponds to the Max.operating frequency. Range: 0~10V→-10~+10V</p>
AFM2		<p>0~10V, Max. Output current: 2mA, Max. load: 5Kω -10~10V, Max. output current: 2mA, Max. load: 5kΩ Output current:: 2mA max Resolution: 0~10V corresponds to the Max.operating frequency. Range: 0~10V→-10~+10V</p>
RJ-45	<p>PIN 1,2,6,7 : Reserved PIN 3: SGND PIN 4: SG- PIN 5: SG+ PIN 8: EV</p>	
SW2	Switching USB port	DIP Switch: NRM(factory setting)/ PRG

06 Optional Accessories

The optional accessories listed in this chapter are available upon request. Installing additional accessories to your drive would substantially improve the drive's performance. Please select an applicable accessory according to your need or contact the local distributor for suggestion.

6-1 Brake Resistors & Brake Units used in AC motor Drives

Voltage	Applicable Motor	*125% Braking Torque /10%ED							**Max. Brake Torque			
		***Braking Torque (kg-m)	Brake Unit		Resistor value spec. for each AC motor Drive	Braking Resistor series for each Brake Unit			Braking Current (A)	Min. Resistor Value(Ω)	Max. Total Braking Current(A)	Peak Power (kW)
			VFDB	Quantity		****Part#	Quantity	Wiring method				
230V	VFD022ED 21S	1.5			300W 70Ω	BR300W070	1		5.4	38.0	10	3.8
	VFD037ED 21S	2.5			400W 40Ω	BR400W040	1		9.5	19.0	20	7.6
	VFD040ED 23S	2.5			400W 40Ω	BR400W040	1		9.5	19.0	20	7.6
	VFD055ED 23S	3.7			1000W 20Ω	BR1K0W020	1		19	15.6	24	9.3
	VFD075ED 23S	5.1			1500W 13Ω	BR1K5W013	1		29	11.5	33	12.5
	VFD110ED 23S	7.5			1500W 13Ω	BR1K5W013	1		29	9.5	40	15.2
	VFD150ED 23S	10.2			2000W 8.6Ω	BR1K0W4P3	2	2 serial	44	8.3	46	17.5
	VFD185ED 23S	12.2			2400W 7.8Ω	BR1K2W3P9	2	2 serial	49	5.8	66	25.1
	VFD220ED 23S	14.9			3000W 6.6Ω	BR1K5W3P3	2	2 serial	58	5.8	66	25.1
	VFD300ED 23S	20.3	2015	2	4000W 5.1Ω	BR1K0W5P1	2	2 serial	75	4.8	80	30.4
	VFD370ED 23S	25.1	2022	2	4800W 3.9Ω	BR1K2W3P9	2	2 serial	97	3.2	120	45.6
460V	VFD040ED 43S	2.7			1000W 75Ω	BR1K0W075	1		10.2	54.3	14	10.6
	VFD055ED 43S	3.7			1000W 75Ω	BR1K0W075	1		10.2	48.4	16	11.9

VFD075ED 43S	5.1			1500W 43Ω	BR1K5W043	1		17.6	39.4	19	14.7
VFD110ED 43S	7.5			1500W 43Ω	BR1K5W043	1		17.6	42.2	18	13.7
VFD150ED 43S	10.2			2000W 32Ω	BR1K0W016	2	2 serial	24	25.0	30	23.1
VFD185ED 43S	12.2			3000W 26Ω	BR1K5W013	2	2 serial	29	20.8	37	27.7
VFD220ED 43S	14.9			3000W 26Ω	BR1K5W013	2	2serial	29	19.0	40	30.4
VFD300ED 43S	20.3			4000W 16Ω	BR1K0W016	4	2 parallel 2 serial	47.5	14.1	54	41.0
VFD370ED 43S	25.1	4045	1	4800W 15Ω	BR1K2W015	4	2parallel 2 serial	50	12.7	60	45.6
VFD450ED 43S	30.5	4045	1	6000W 13Ω	BR1K5W013	4	2 parallel 2 serial	59	12.7	60	45.6
VFD550ED 43S	37.2	4030	2	8000W 10.2Ω	BR1K0W5P1	4	4 serial	76	9.5	80	60.8
VFD750ED 43S	50.8	4045	2	9600W 7.5Ω	BR1K2W015	4	2 parallel 2 serial	100	6.3	120	91.2

*Calculation of 125% brake torque: (kw)*125%*0.8; where 0.8 is the motor efficiency.

Since there is a resistor limit of power consumption, the longest operation time for 10%ED is 10 sec (On: 10sec/ Off: 90sec).

**Refer to the Brake Performance Curve for “Operation Duration & ED” vs. “Braking Current”.

***The calculation of the braking torque is based on a 4-pole motor(1800 rpm).

****To dissipate heat, a resistor of 400W or lower should be fixed to the frame and maintain the surface temperature below 250°C (**482 °F**); a resistor of 1000W and above should maintain the surface temperature below 600°C (**1112 °F**). If the surface temperature is higher than the temperature limit, install more heat dissipating system or increase the size of the resistor.

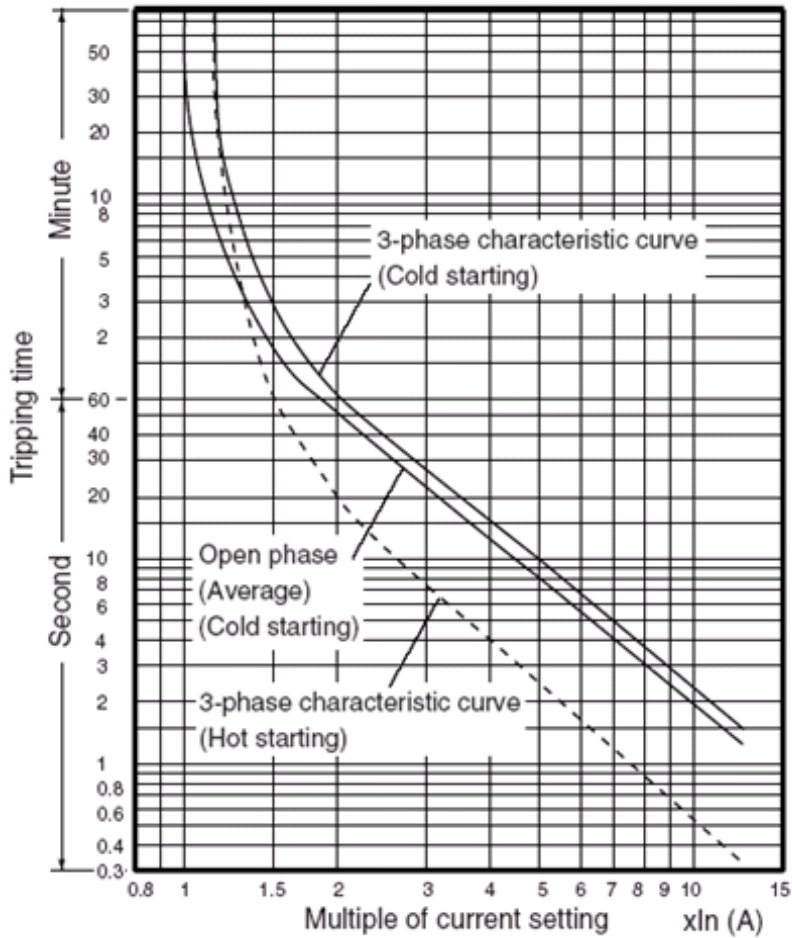

Thermal Relay:

Thermal relay selection is based on its overload capability. A standard braking capacity of ED is 10%ED (Tripping time=10s). The figure on the left is an example of 460V, 110kw AC motor drive. It requires the thermal relay to take 260% overload capacity for 10sec (hot starting) and the braking current is 126A. In this case, user should select a rated 50A thermal relay. The property of each thermal relay may vary among different manufacturers. Read carefully the user guide of a thermal relay before using it. .

6-2 Non-fuse Circuit Breaker

Comply with UL standard: Per UL 508, paragraph 45.8.4, part a. The rated current of a breaker shall be 2~4 times of the maximum rated input current of AC motor drive.

3-phase		3-phase	
Model	Recommended non-fuse breaker(A)	Model	Recommended non-fuse breaker(A)
VFD022ED21S	50	VFD040ED43S	20
VFD037ED21S	50	VFD055ED43S	30
VFD040ED23S	40	VFD075ED43S	40
VFD055ED23S	50	VFD110ED43S	50
VFD075ED23S	60	VFD150ED43S	60
VFD110ED23S	100	VFD185ED43S	75
VFD150ED23S	125	VFD220ED43S	100
VFD185ED23S	150	VFD300ED43S	125
VFD220ED23S	175	VFD370ED43S	150
VFD300ED23S	225	VFD450ED43S	175
VFD370ED23S	250	VFD550ED43S	250
		VFD750ED43S	300

6-3 Fuse Specification Chart

- Use only the fuses comply with UL certificated.
- Use only the fuses comply with local regulations.

Model	Input Current (A)	Output Current (A)	Line Fuse	
			I (A)	Bussmann P/N
VFD022ED21S	26	12	50	JJN-50
VFD037ED21S	17	17	50	JJN-50
VFD040ED23S	23	20	40	JJN-40
VFD055ED23S	26	25	50	JJN-50
VFD075ED23S	34	33	60	JJN-60
VFD110ED23S	50	49	100	JJN-100
VFD150ED23S	60	65	125	JJN-125
VFD185ED23S	75	75	150	JJN-150
VFD220ED23S	90	90	175	JJN-175
VFD300ED23S	110	120	225	JJN-225
VFD370ED23S	142	145	250	JJN-250
VFD040ED43S	13	11.5	50	JJN-20
VFD055ED43S	14	13	30	JJN-30
VFD075ED43S	19	18	40	JJN-40
VFD110ED43S	25	24	50	JJN-50
VFD150ED43S	32	32	60	JJN-60
VFD185ED43S	39	38	75	JJN-70
VFD220ED43S	49	45	100	JJN-100
VFD300ED43S	60	60	125	JJN-125
VFD370ED43S	63	73	150	JJN-150
VFD450ED43S	90	91	175	JJN-175
VFD550ED43S	130	110	250	JJN-250
VFD750ED43S	160	150	300	JJN-300

6-4 AC/ DCRactor

AC Input/ Output Reactor

200V~230V/ 50~60Hz (Single Phase Power)

Type	KW	HP	Rated Amps (Arms)	Max. Continuous Amps (Arms)	3% impedance (mH)	5% impedance (mH)	Built-in DC Reactor	3% Input AC reactor Delta Part#
022	2.2	3	12	24	0.919	1.531	X	N/A
037	3.7	5	17	34	0.649	1.081	X	N/A

200V~230V/ 50~60Hz (Three-phase power)

Type	KW	HP	Rated Amps (Arms)	Max. Continuous Amps (Arms)	3% impedance (mH)	5% impedance (mH)	Built-in DC Reactor	3% Input AC reactor Delta Part#
040	4	5	20	40	0.551	0.919	X	N/A
055	5.5	7.5	24	48	0.459	0.766	X	N/A
075	7.5	10	30	60	0.320	0.534	X	N/A
110	11	15	45	90	0.216	0.359	X	N/A
150	15	20	58	116	0.163	0.271	X	N/A
185	18.5	25	77	154	0.143	0.239	X	N/A
220	22	30	87	174	0.127	0.211	X	N/A
300	30	40	132	264	0.084	0.139	O	N/A
370	37	50	161	322	0.068	0.114	O	N/A

380V~460V/ 50~60Hz (Three-phase power)

Type	KW	HP	Rated Amps (Arms)	Max. Continuous Amps (Arms)	3% impedance (mH)	5% impedance (mH)	Built-in DC Reactor	3% Input AC reactor Delta Part#
040	4	5	11.5	23	1.838	3.063	X	N/A
055	5.5	7.5	13	26	1.626	2.710	X	N/A
075	7.5	10	17	34	1.243	2.072	X	N/A
110	11	15	23	46	0.919	1.531	X	N/A
150	15	20	30	60	0.704	1.174	X	N/A
185	18.5	25	38	76	0.556	0.927	X	N/A
220	22	30	45	90	0.470	0.783	X	N/A
300	30	40	58	116	0.364	0.607	X	N/A
370	37	50	80	160	0.264	0.440	O	N/A
450	45	60	100	200	0.211	0.352	O	N/A
550	55	75	121	242	0.175	0.291	O	N/A
750	75	100	146	292	0.145	0.241	O	N/A

DC Input/Output Reactor

200V~230V/ 50~60Hz (Three-phase power)

Type	KW	HP	Rated Amps (Arms)	Max. Continuous Amps (Arms)	DC Reactor (mH)	DC Reactor Delta Part#
040	4	5	20	40	1.273	N/A
055	5.5	7.5	24	48	1.061	N/A
075	7.5	10	30	60	0.740	N/A
110	11	15	45	90	0.498	N/A
150	15	20	58	116	0.375	N/A
185	18.5	25	77	154	0.331	N/A
220	22	30	87	174	0.293	N/A
300	30	40	132	264	0.193	N/A
370	37	50	161	322	0.158	N/A

380V~460V/ 50~60Hz(Three-phase power)

Type	KW	HP	Rated Amps (Arms)	Max. Continuous Amps (Arms)	DC Reactor (mH)	DC Reactor Delta Part#
040	4	5	11.5	23	4.244	N/A
055	5.5	7.5	13	26	3.754	N/A
075	7.5	10	17	34	2.871	N/A
110	11	15	23	46	2.122	N/A
150	15	20	30	60	1.627	N/A
185	18.5	25	38	76	1.284	N/A
220	22	30	45	90	1.085	N/A
300	30	40	58	116	0.842	N/A
370	37	50	80	160	0.610	N/A
450	45	60	100	200	0.488	N/A
550	55	75	121	242	0.403	N/A
750	75	100	146	292	0.334	N/A

THD (Total Harmonic Distortion)

Motor Drive Spec.	Without Built-In Reactor				With Built-in DC Reactor
Reactor Spec.	3% Input AC Reactor	DC Reactor	DC Reactor + 3% Input Reactor	DC + 5% Input Reactor	3% Input Reactor
THD	44%	46%	34%	30%	34%
Note:	THD may varies due to different installation conditions and environment (wires, motors).				

According to IEC61000-3-12, DC Reactor is designed with 4% system impedance, and AC Reactor is designed with 3% system impedance.

6-5 Zero Phase Reactor

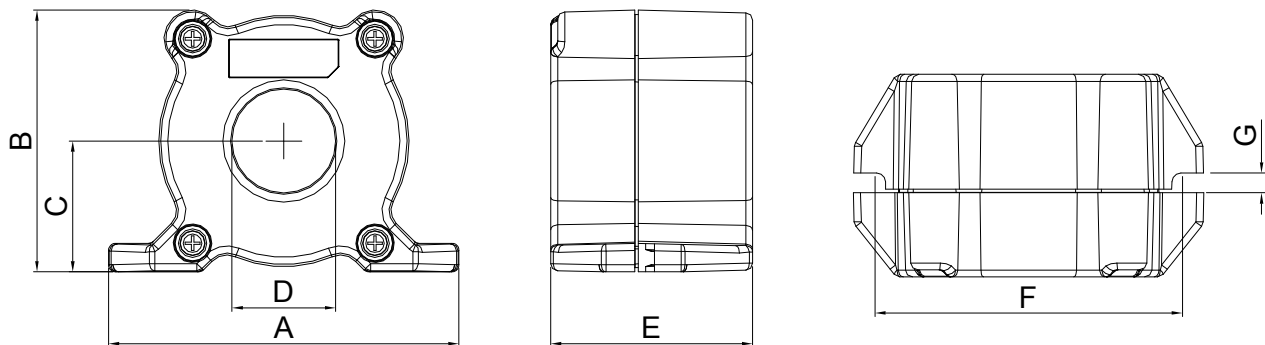

unit: mm(inch)

Model	A	B	C	D	E	F	G(∅)	Torque
RF008X00A	98 (3.858)	73 (2.874)	36.5 (1.437)	29 (1.142)	56.5 (2.224)	86 (3.386)	5.5 (0.217)	8~ 10kgf/cm
RF004X00A	110 (4.331)	87.5 (3.445)	43.5 (1.713)	36 (1.417)	53 (2.087)	96 (3.780)	5.5 (0.217)	8~ 10kgf/cm

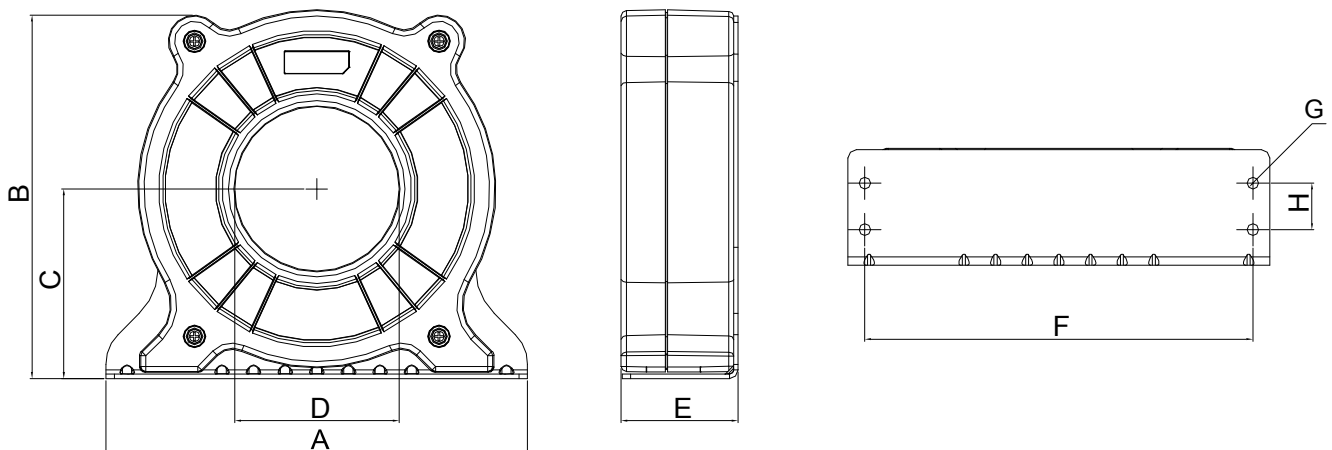

unit: mm(inch)

model	A	B	C	D	E	F	G(∅)	H	Torque
RF002X00A	200 (7.874)	172.5 (6.791)	90 (3.543)	78 (3.071)	55.5 (2.185)	184 (7.244)	5.5 (0.217)	22 (0.866)	40~45kgf/cm

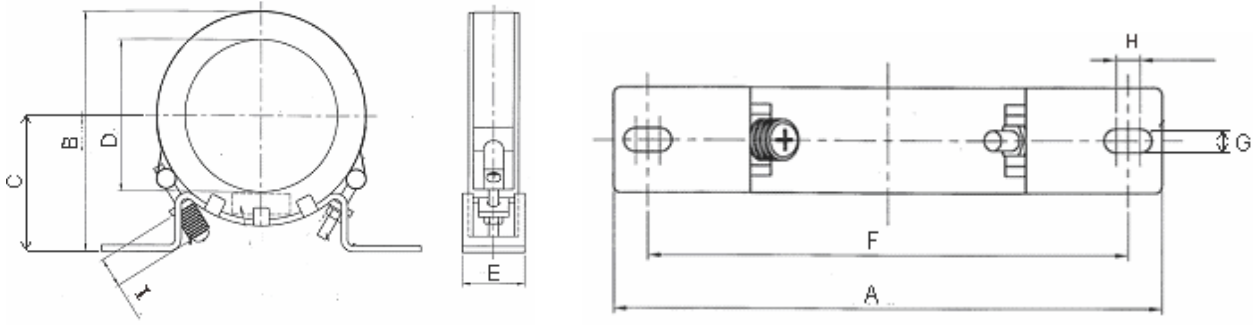

unit: mm(inch)

model	A	B	C	D	E	F	G(Ø)	H	I
RF300X00A	241(9.488)	217(8.543)	114(4.488)	155(6.102)	42(1.654)	220(8.661)	6.5(0.256)	7.0(0.276)	20(0.787)
									Torque:40~45kgf/cm

Reactor model (Note)	Recommended Wire Size		Wiring Method	Qty	Applicable Motor Drive
RF008X00A	≤ 8 AWG	≤ 8.37 mm ²	Diagram A	1	VFD022ED21S VFD037ED21S VFD040ED23S VFD040ED43S
RF004X00A	≤ 4 AWG	≤ 21.15 mm ²	Diagram A	1	VFD055ED23S VFD075ED23S VFD110ED23S VFD055ED43S VFD075ED43S VFD110ED43S VFD150ED43S VFD185ED43S
RF002X00A	≤ 2 AWG	≤ 33.62 mm ²	Diagram A	1	VFD150ED23S VFD185ED23S VFD220ED23S VFD220ED43S VFD300ED43S
RF300X00A	≤ 300 MCM	≤ 152 mm ²	Diagram A	1	VFD300ED23S VFD370ED23S VFD370ED43S VFD450ED43S VFD550ED43S VFD750ED43S

Note: 600V insulated cable wire

Diagram A

Put all wires through at least one core without winding

Zero Phase Reactor

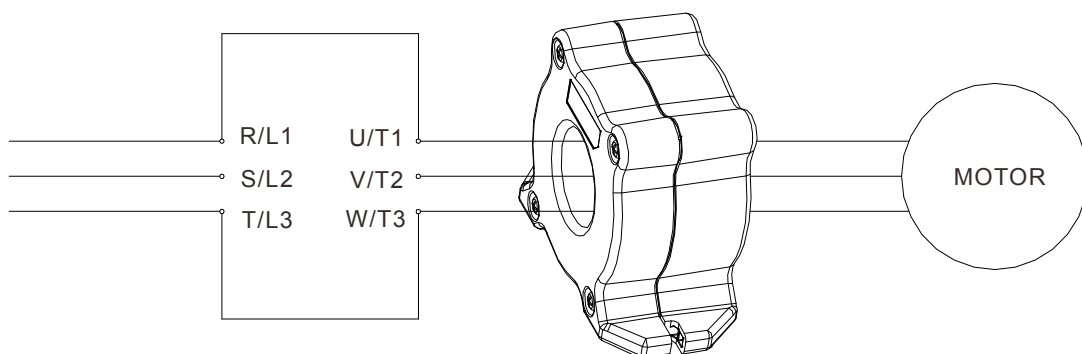

Note 1: The table above gives approximate wire size for the zero phase reactors but the selection is ultimately governed by the type and diameter of cable fitted i.e. the cable must fit through the center hole of zero phase reactors.

Note 2: Only the phase conductors should pass through, not the earth core or screen.

Note3: When long motor output cables are used an output zero phase reactor may be required to reduce radiated emissions from the cable.

6-6 EMI Filter

For the detailed specifications of the EMI filters listed in the table below, search the Internet.

Motor Drive	Applicable EMI Filter
VFD022ED21S VFD037ED21S	MDF50 (Roxburgh EMC)
VFD040ED43S VFD055ED43S	EMF018A43A
VFD075ED43S VFD110ED43S	EMF033A43A
VFD040ED23S VFD055ED23S	EMF035A23A
VFD075ED23S VFD110ED23S	EMF056A23A
VFD150ED43S	EMF039A43A
VFD185ED43S VFD220ED43S	KMF370A (Roxburgh EMC)
VFD150ED23S VFD185ED23S VFD300ED43S VFD370ED43S	KMF3100A (Roxburgh EMC)
VFD220ED23S VFD450ED43S VFD550ED43S	B84143D0150R127
VFD300ED23S VFD370ED23S VFD750ED43S	B84143D0200R127

EMI Filter Installation

All electrical equipment, including AC motor drives, will generate high-frequency/low-frequency noise and will interfere with peripheral equipment by radiation or conduction when in operation. By using an EMI filter with correct installation, much interference can be eliminated. It is recommended to use DELTA EMI filter to have the best interference elimination performance.

We assure that it can comply with following rules when AC motor drive and EMI filter are installed and wired according to user manual:

- **EN61000-6-4**
- **EN61800-3: 1996**
- **EN55011: (1991) Class A Group 1 (1st Environment, restricted distribution)**

General precaution

1. EMI filter and AC motor drive should be installed on the same metal plate.
2. Install AC motor drive on footprint EMI filter or install EMI filter as close as possible to the AC motor drive.
3. Wire as short as possible.
4. Metal plate should be grounded.
5. The cover of EMI filter and AC motor drive or grounding should be fixed on the metal plate and the contact area should be as large as possible.

Choose suitable motor cable and precautions

Improper installation and choice of motor cable will affect the performance of EMI filter. Be sure to observe the following precautions when selecting motor cable.

1. Use the cable with shielding (double shielding is the best).
2. The shielding on both ends of the motor cable should be grounded with the minimum length and maximum contact area.
3. Remove any paint on metal saddle for good ground contact with the plate and shielding.

Remove any paint on metal saddle for good ground contact with the plate and shielding.

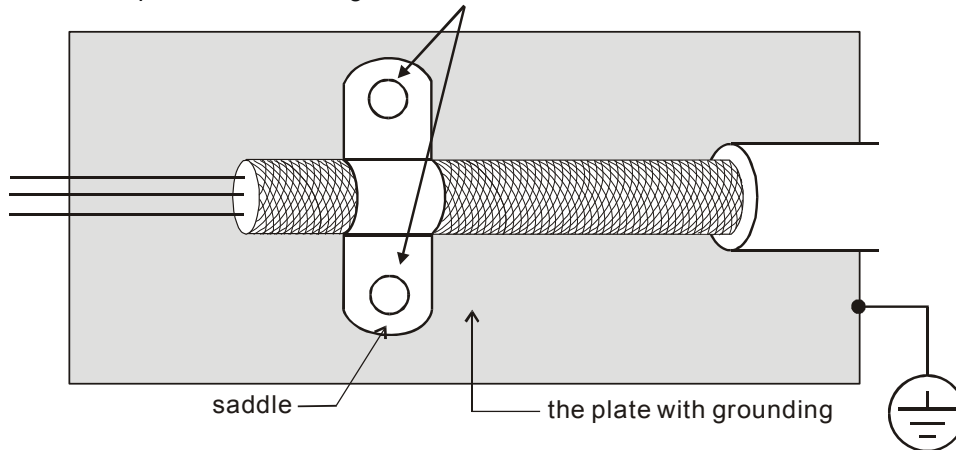

Figure 1

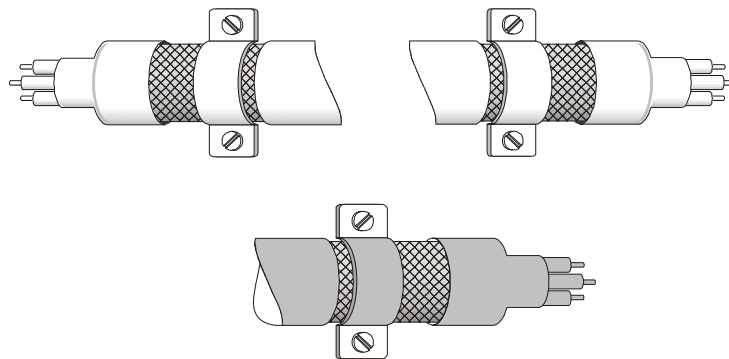

Figure 2

The length of motor cable

1. Required cable length when the motor drive is at full load.

- a. Non-shielded cable: For models of 5.5kW(7.5HP) and below, the maximum cable length is 100m (328ft) . For 7.5kW(10HP) and above, the maximum cable length is 200m(656ft)
- b. Shielded cable: For models of 5.5kw(7.5HP) and below, the maximum cable length is 50m(165ft). For models of 7.5kW(10HP), the maximum cable length is 100m(328ft).

If the cable length is longer than the recommended lengths above, it will be necessary to install an output reactor.

NOTE

- If the length is too long, the stray capacitance between cables will increase and may cause leakage current. It will activate the protection of over current, increase leakage current or not insure the correction of current display. The worst case is that AC motor drive may damage.
- If more than one motor is connected to the AC motor drive, the total wiring length is the sum of the wiring length from AC motor drive to each motor.
- For the 460V series AC motor drive, when an overload relay is installed between the drive and the motor to protect motor over heating, the connecting cable must be shorter than 50m. However, an overload relay malfunction may still occur. To prevent the malfunction, install an output reactor (optional) to the drive or lower the carrier frequency setting (Pr.00-12).

2. Consequence of the surge voltages on the motor

When a motor is driven by an AC motor drive of PWM type, the motor terminals will experience surge voltages easily due to components conversion of AC motor drive and cable capacitance. When the motor cable is very long (especially for the 460V series), surge voltages may reduce insulation quality. To prevent this situation, please follow the rules below:

- Use a motor with enhanced insulation.
- Connect an output reactor (optional) to the output terminals of the AC motor drive
- The length of the cable between AC motor drive and motor should be as short as possible (10 to 20 m or less)
- For models 7.5hp and above:

Insulation level of motor	1000V	1300V	1600V
460VAC input voltage	20m(66ft)	100m(328ft)	400m(1312ft)
230VAC input voltage	400m(1312ft)	400m(1312ft)	400m(1312ft)

- For models 5hp and less:

Insulation level of motor	1000V	1300V	1600V
460VAC input voltage	20m(66ft)	50m(165ft)	50m(165ft)
230VAC input voltage	100m(328ft)	100m(328ft)	100m(328ft)

NOTE

Never connect phase lead capacitors or surge absorbers to the output terminals of the AC motor drive.

6-7 Digital Keypad

1 KPC-CE01



A: LED Display

Display frequency, current, voltage and error etc.

B: Status Indicator

F: Frequency Command

H: Output Frequency

U: User Defined Units

ERR: CAN Error Indicator



RUN: CAN Run Indicator

C: Function

(Refer to the chart follows for detail description)

Key	Description
ESC	ESC Key Press ESC key to return to the previous page. It also functions as a return to last category key in the sub-menu.
MENU	Menu Key Press MENU key under any condition will return to the main MENU. Menu content: 1. Parameter Detail 2. Copy Parameter 3. Keypad locked 4. PLC Function
ENTER	ENTER Key Press ENTER and go to the next level. If it is the last level then press ENTER to execute the command.
HAND	HAND ON Key 1. HAND key will operates according to the parameter settings when the source of HAND master frequency command and the source of HAND operation command is properly set,. The factory setting of the source command for frequency and operation are from the digital keypad . 2. Press HAND key in stop status, the drive setting switches to the parameter setting of HAND. Press HAND key in during operation, the drive will come to stop then switches to the parameter setting of HAND. 3. When process complete: H/A LED ON.
AUTO	Auto Operation Key 1. AUTO function executes according to the parameter settings of the source of AUTO frequency and AUTO operation. The factory setting is the external terminal (source of operation is 4-20mA). 2. Press the ATUO key in stop status, the drivel switches to auto-setting. Press the auto key during operation status, the drivel will come to stop and switch to auto-setting. 3. When process complete: H/A LED is OFF
FWD/REV	Operation Direction Key 1. FWD/REV key controls the operation direction but will NOT activate the drive. FWD: forward, REV: reverse. 2. The drive operates in the direction as shown by the LED light.
RUN	Start Key 1. This button is functional only when the keypad is the source of the command. 2. This button allows the motor drive to run by following its settings. See Description of LED functions for LED status 3. Press repeatedly the "RUN" button is allow while the motor drive is stopping.
STOP	Stop Key. 1. STOP key has the highest priority in command. 2. Press STOP key, the drive will come to stop under any condition. 3. The RESET key can be used to reset the drive when faults occur. If the RESET key is not responding, check MENU → Fault Records and check the most recent fault.

Descriptions of LED Functions

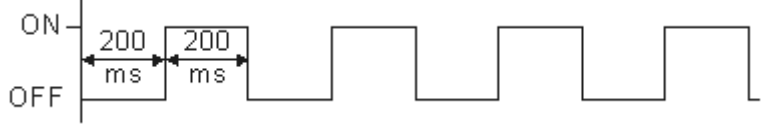
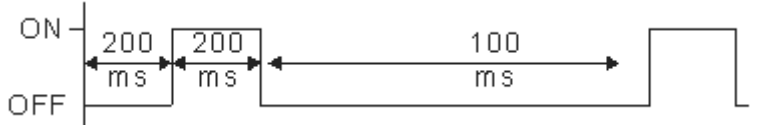
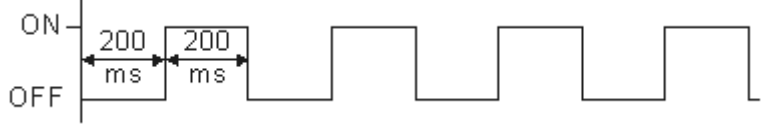
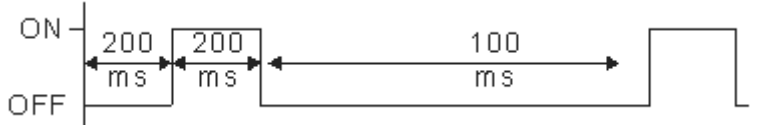
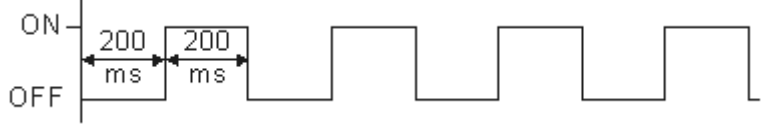
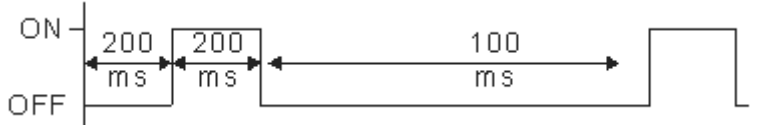
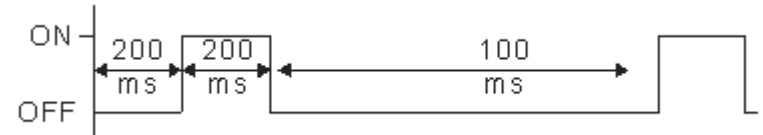
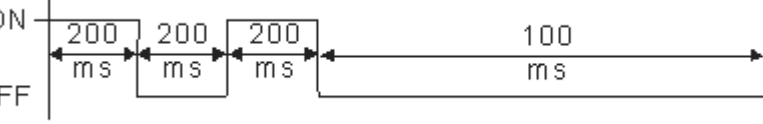
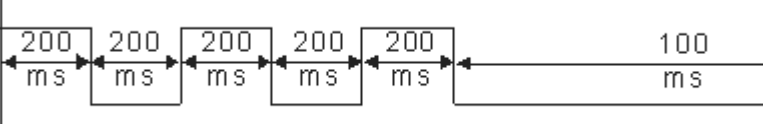
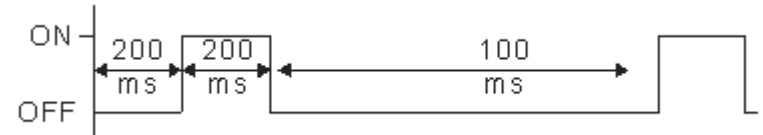
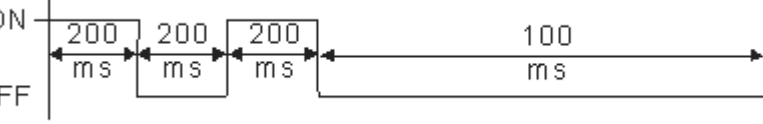
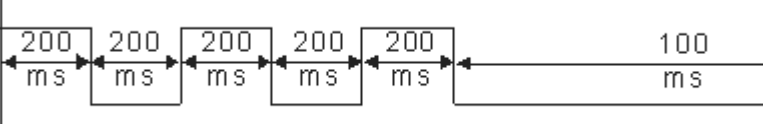
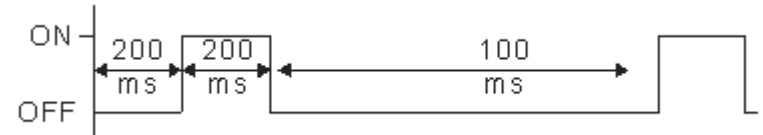
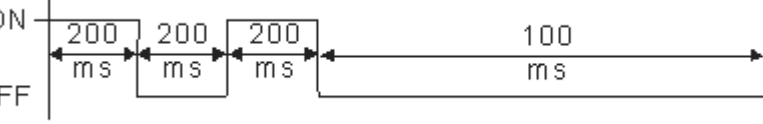
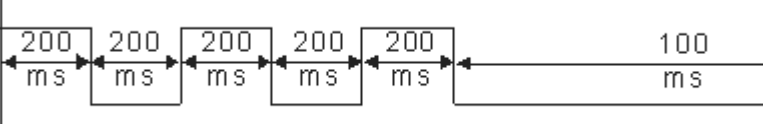
LED	Descriptions												
	<p>Steady ON: operation indicator of the AC motor drive, including DC brake, zero speed, standby, restart after fault and speed search.</p> <p>Blinking: drive is decelerating to stop or in the status of base block.</p> <p>Steady OFF: drive doesn't execute the operation command</p>												
	<p>Steady ON: stop indicator of the AC motor drive.</p> <p>Blinking: drive is in the standby status.</p> <p>Steady OFF: drive doesn't execute "STOP" command.</p>												
	<p>Operation Direction LED 『Green light= Forward』; 『Red light= Reversely』</p> <p>Steady ON: the drive is running forward.</p> <p>Blinking: the drive is changing direction.</p> <p>Steady Off: the drive is running reversely.</p>												
<p>CANopen ~"RUN"</p>	<p>RUN (Green light):</p> <table border="1" data-bbox="359 689 1460 1209"> <thead> <tr> <th data-bbox="359 689 491 750">LED status</th> <th data-bbox="491 689 1460 750">Condition/State</th> </tr> </thead> <tbody> <tr> <td data-bbox="359 750 491 817">OFF</td> <td data-bbox="491 750 1460 817">CANopen at initial No LED</td> </tr> <tr> <td data-bbox="359 817 491 981">Blinking</td> <td data-bbox="491 817 1460 981">CANopen at pre-operation  </td> </tr> <tr> <td data-bbox="359 981 491 1153">Single flash</td> <td data-bbox="491 981 1460 1153">CANopen at stopped  </td> </tr> <tr> <td data-bbox="359 1153 491 1209">ON</td> <td data-bbox="491 1153 1460 1209">CANopen at operation status No LED</td> </tr> </tbody> </table>	LED status	Condition/State	OFF	CANopen at initial No LED	Blinking	CANopen at pre-operation 	Single flash	CANopen at stopped 	ON	CANopen at operation status No LED		
LED status	Condition/State												
OFF	CANopen at initial No LED												
Blinking	CANopen at pre-operation 												
Single flash	CANopen at stopped 												
ON	CANopen at operation status No LED												
<p>CANopen ~"ERR"</p>	<p>ERR (Red light):</p> <table border="1" data-bbox="359 1272 1460 1982"> <thead> <tr> <th data-bbox="359 1272 491 1332">LED status</th> <th data-bbox="491 1272 1460 1332">Condition/ State</th> </tr> </thead> <tbody> <tr> <td data-bbox="359 1332 491 1366">OFF</td> <td data-bbox="491 1332 1460 1366">No Error</td> </tr> <tr> <td data-bbox="359 1366 491 1568">Single flash</td> <td data-bbox="491 1366 1460 1568">One message fail  </td> </tr> <tr> <td data-bbox="359 1568 491 1758">Double flash</td> <td data-bbox="491 1568 1460 1758">Guarding fail or heartbeat fail  </td> </tr> <tr> <td data-bbox="359 1758 491 1960">Triple flash</td> <td data-bbox="491 1758 1460 1960">SYNC fail  </td> </tr> <tr> <td data-bbox="359 1960 491 2000">ON</td> <td data-bbox="491 1960 1460 2000">Bus off</td> </tr> </tbody> </table>	LED status	Condition/ State	OFF	No Error	Single flash	One message fail 	Double flash	Guarding fail or heartbeat fail 	Triple flash	SYNC fail 	ON	Bus off
LED status	Condition/ State												
OFF	No Error												
Single flash	One message fail 												
Double flash	Guarding fail or heartbeat fail 												
Triple flash	SYNC fail 												
ON	Bus off												

Dimension

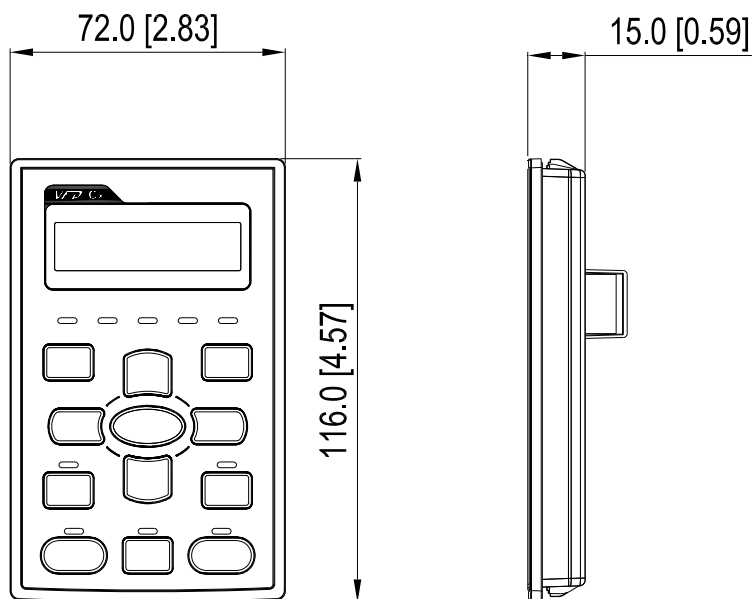

RJ45 Extension Lead for Digital Keypad

Part #	Description
CBC-K3FT	3 feet RJ45 extension lead (approximately 0.9m)
CBC-K5FT	5 feet RJ45 extension lead (approximately 1.5 m)
CBC-K7FT	7 feet RJ45 extension lead (approximately 2.1 m)
CBC-K10FT	10 feet RJ45 extension lead (approximately 3 m)
CBC-K16FT	16 feet RJ45 extension lead (approximately 4.9 m)

6-8 USB/RS-485 Communication Interface IFD6530

Warning

- ✓ Read thoroughly this section before installation and putting it into use.
- ✓ The content of this section and the driver file may be revised without prior notice. Consult our distributors or download the most updated instruction/driver version at [AC Motor Drive > Optional](#)

Introduction

IFD6530 is a convenient RS-485-to-USB converter, which does not require external power-supply and complex setting process. It supports baud rate from 75 to 115.2kbps and auto switching direction of data transmission. In addition, it adopts RJ-45 in RS-485 connector for users to wire conveniently. And its tiny dimension, handy use of plug-and-play and hot-swap provide more conveniences for connecting all DELTA IABU products to your PC.

Applicable Models: All DELTA IABU products.

■ Application & Dimension:

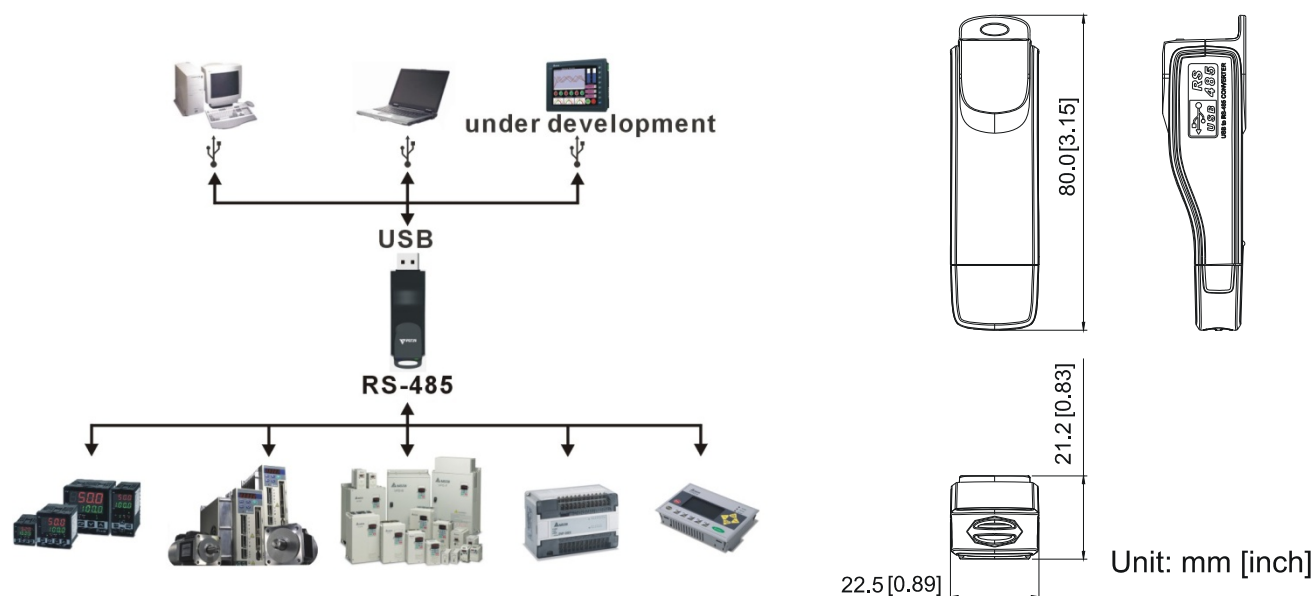

Specifications

Power supply	No external power is needed
Power consumption	1.5W
Isolated voltage	2,500VDC
Baud rate	75, 150, 300, 600, 1,200, 2,400, 4,800, 9,600, 19,200, 38,400, 57,600, 115,200 bps
RS-485 connector	RJ-45
USB connector	A type (plug)
Compatibility	Full compliance with USB V2.0 specification
Max. cable length	RS-485 Communication Port: 100 m
Support RS-485 half-duplex transmission	

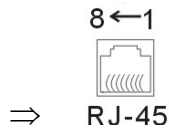
RJ-45

PIN	Description
1	Reserved
2	Reserved
3	GND
4	SG-

PIN	Description
5	SG+
6	GND
7	Reserved
8	+9V

Preparation before Installing Driver

Extract the driver file (IFD6530_Drivers.exe) by following steps. You could find driver file (IFD6530_Drivers.exe) in the CD supplied with IFD6530.

Note: DO NOT connect IFD6530 to PC before extracting the driver file.

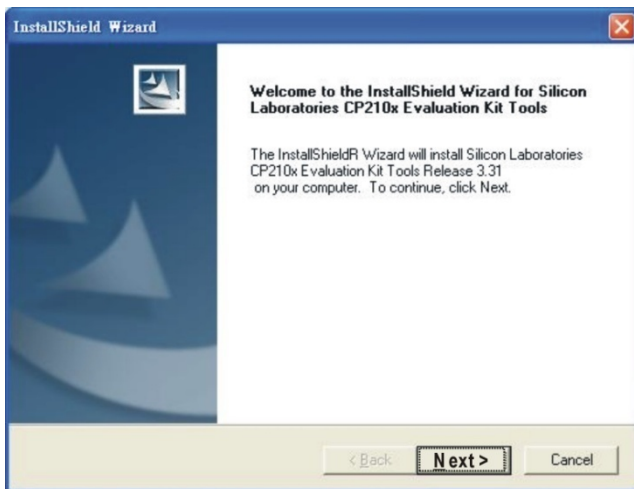
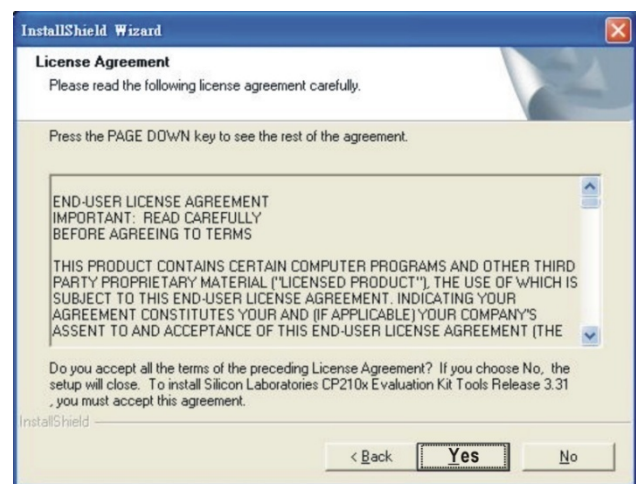
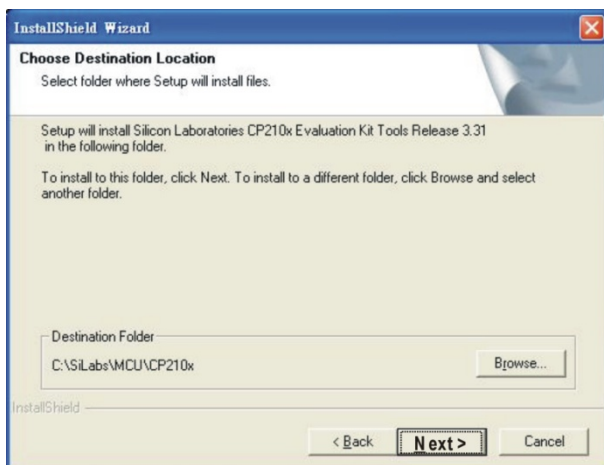
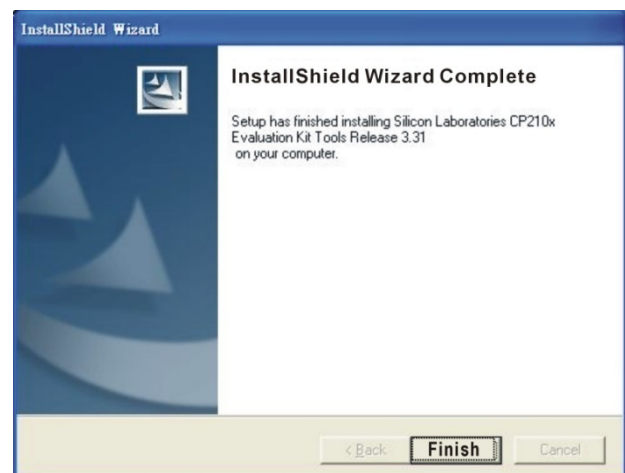
STEP 1**STEP 2****STEP 3****STEP 4****STEP 5**

You should have a folder marked SiLabs under drive C. c:\SiLabs

Intalling the Driver

After connecting IFD6530 to PC, install driver by following steps below.

STEP 1

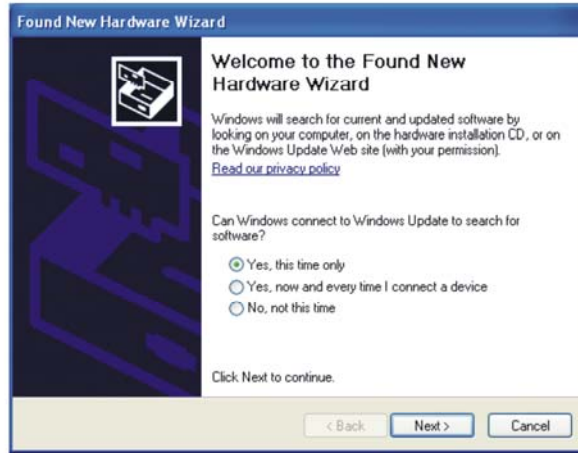

STEP 2

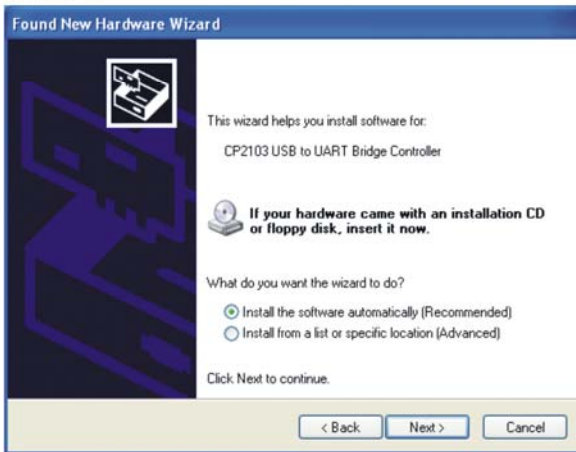

OR

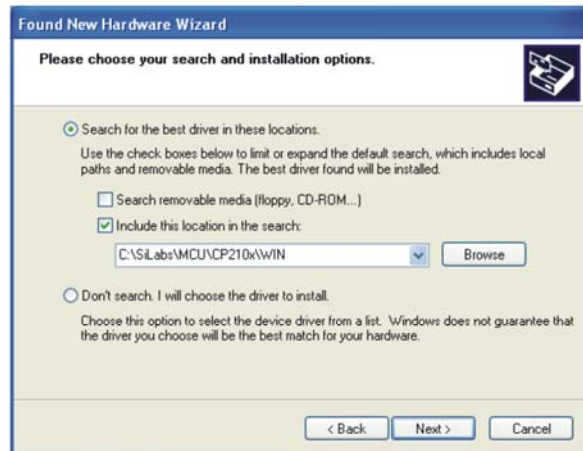
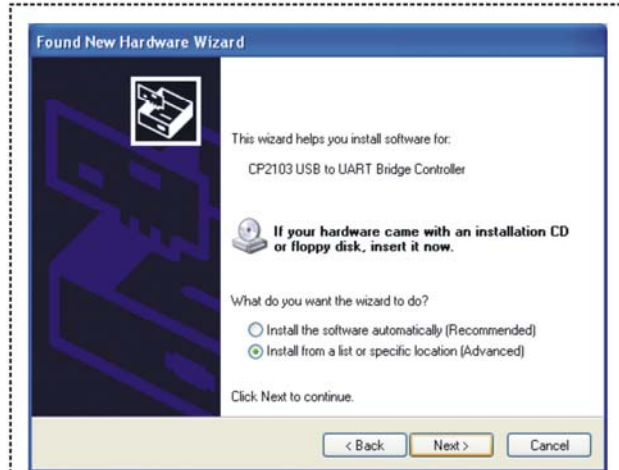

Browse and select directory, or enter
C:\SiLabs\MCU\CP210x\WIN

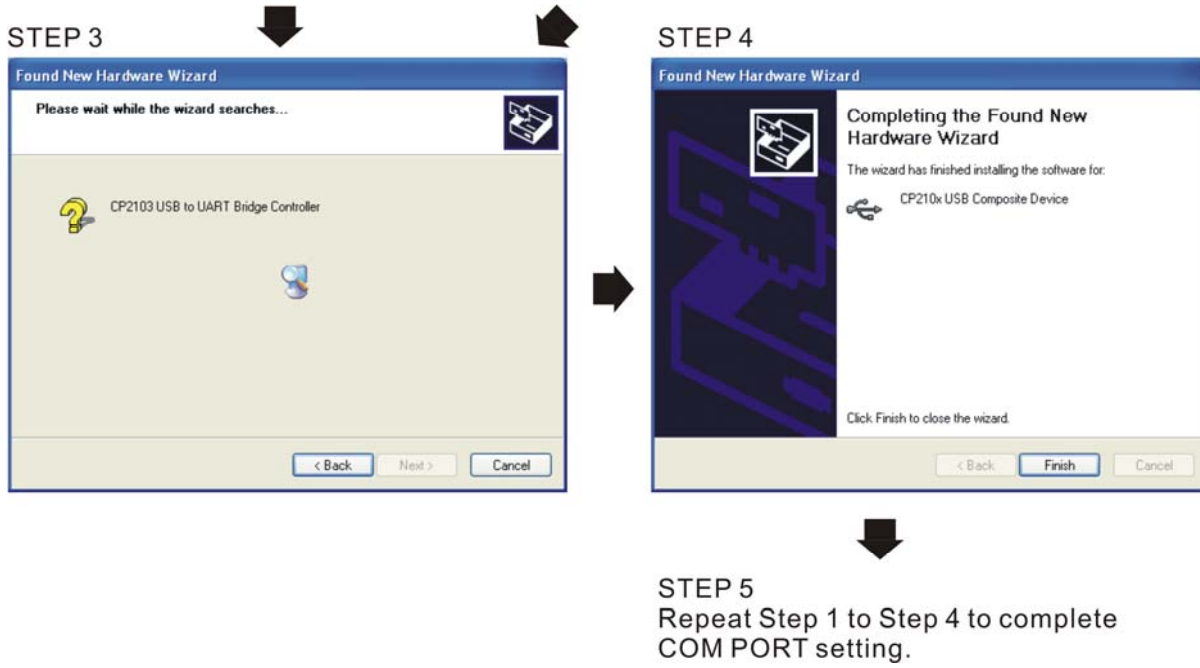

LED Display

1. Steady Green LED ON: power is ON.
2. Blinking orange LED: data is transmitting.

07 Option Cards

Select applicable option cards for your drive or contact local distributor for suggestion.

To prevent drive damage during installation, remove the digital keypad and the cover before wiring. Refer to the following instruction.

Remove the top cover

Frame B, C & D Screw Torque: Kg-cm [lb-in.]

Step 1

Loosen the 4 screws.
Then remove the top cover.

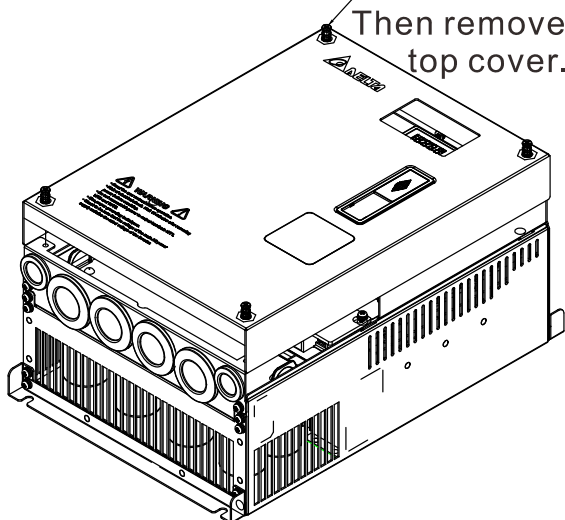

Step 2

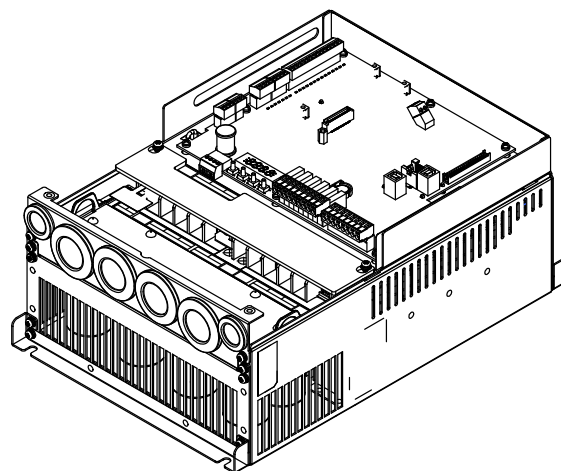

Step 3

Put back the top cover.
Then fasten the 4 screws,
Screw torque 15kgf-cm

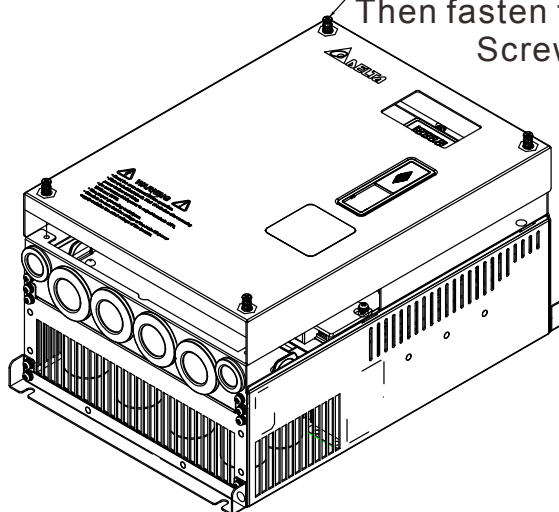

Frame E Screw Torque: Kg-cm [lb-in.]

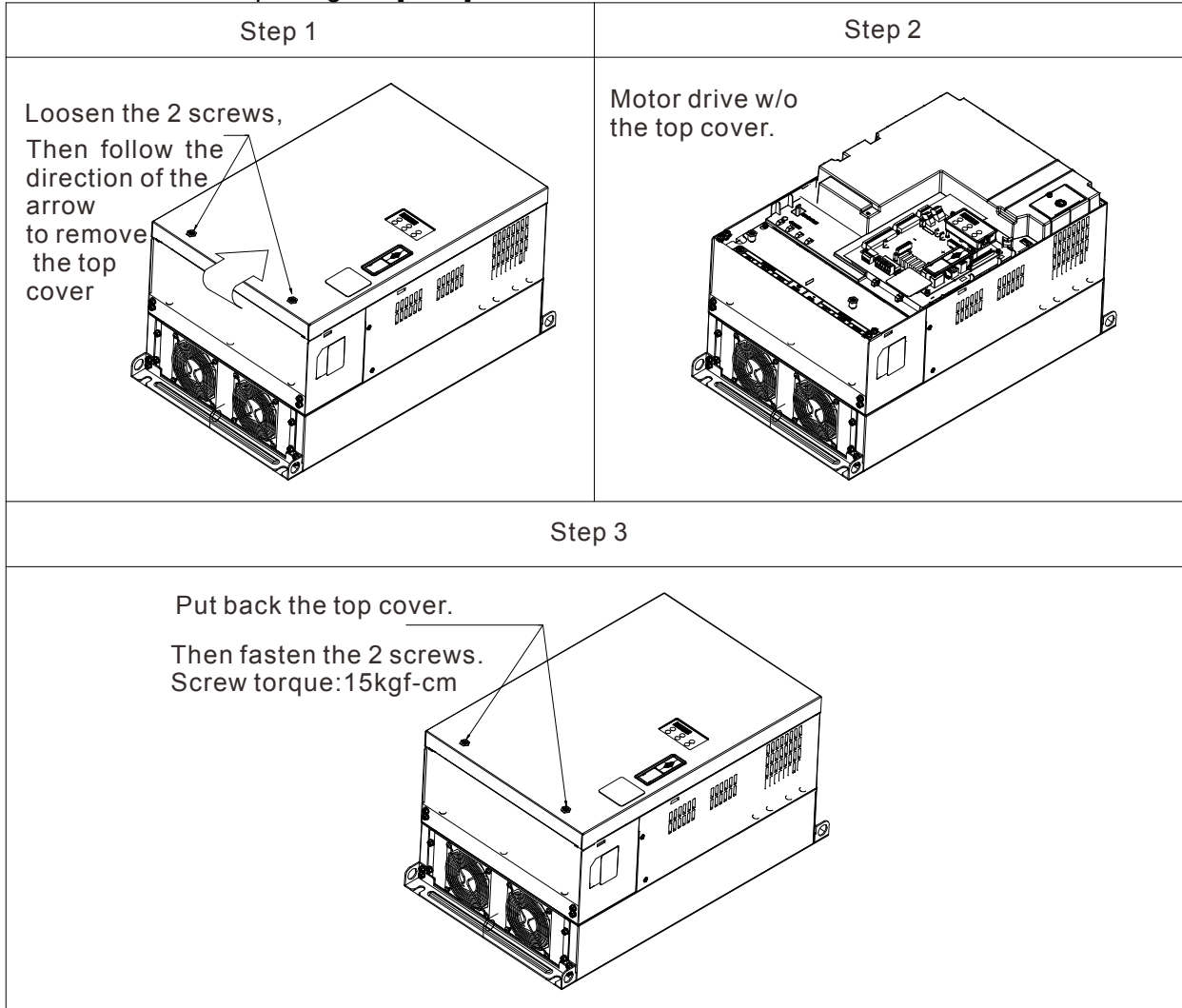

Vertical view of the motor drive & Screw's Specificatons:

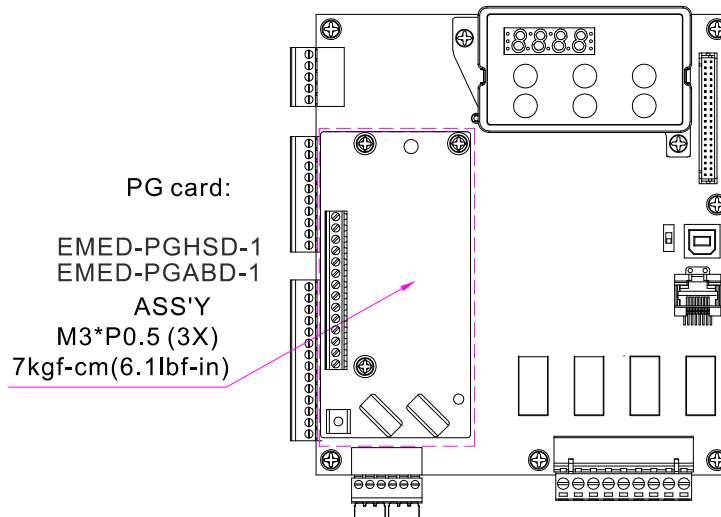

Screws' Specification for Option Card Terminal:

PG Card	Wire Gauge	Torque
EMED-PGABD-1	30~16AWG (0.05~1.31mm ²)	1.6Kg-cm [1.4lb-in]
EMED-PGHSD-1	30~16AWG (0.05~1.31mm ²)	1.6Kg-cm [1.4lb-in]

7-1 EMED-PGABD-1

Applicable enoder: A/B/Z & U/V/W Absolute Encoders

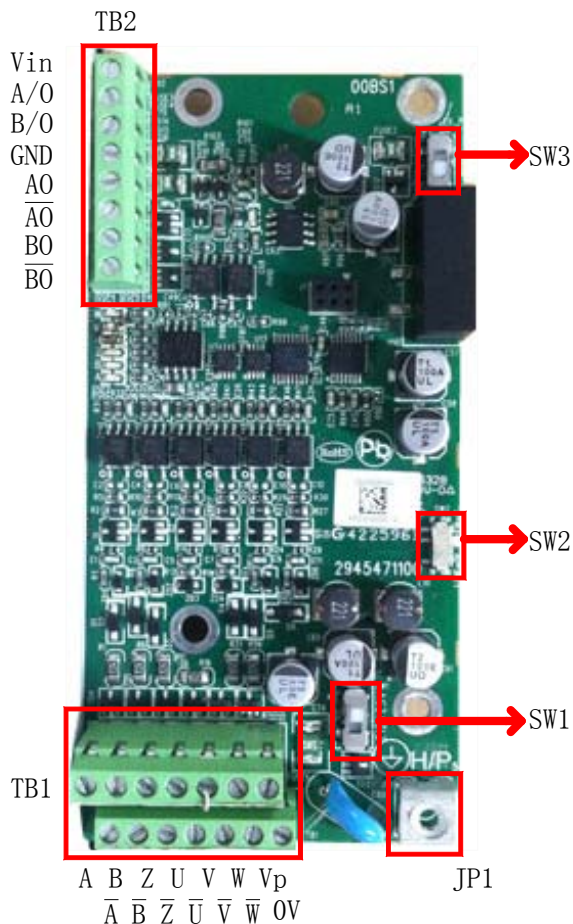

Dimension

unit : mm[inch.]

Dimension Diagram

unit: mm [inch]

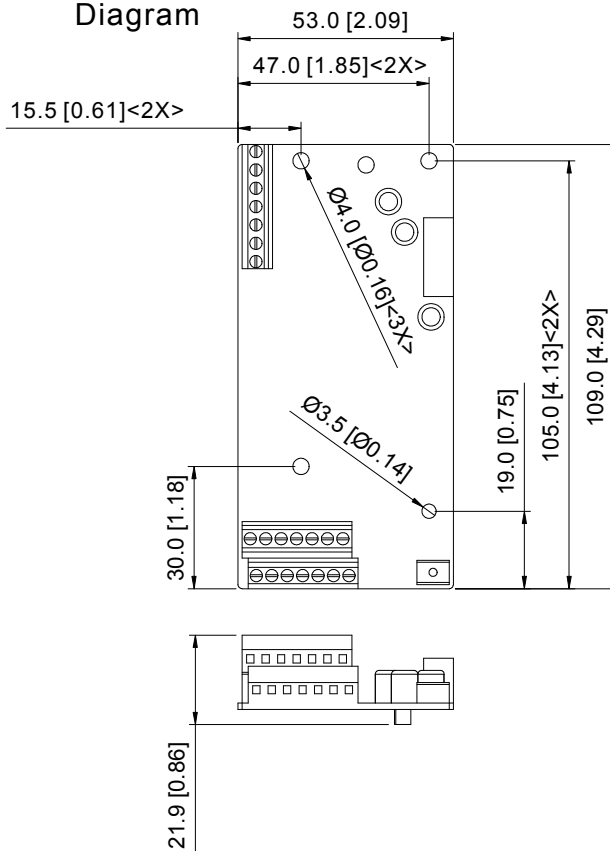

NOTE

- Verify if the SW1 is set to the correct output voltage before power on.
- Keep away from any high voltage line when wiring the mtor drive to avoid interference.

Terminal Specification

Terminals		Descriptions
TB2	Vin	Terminal for voltage input, to adjust the amplitude of output voltage at terminal A/O and terminal B/O. It also provides a 5V voltage to support line driver's signal. Vin voltage range: 8~24V, Max: 24V.
	A/O, B/O	Output signal of the push-pull frequency divider Factory setting: Output amplitude is about +24V. Use SW2 to cut off the internal default power. Input required power (i.e. output voltage's amplitude) DVi voltage range Max : 24V (Push-Pull Voltage Output) Max. output frequency: 100kHz Support frequency dividing output, the frequency dividing range: 1~31Hz.
	GND	Common ground terminal connecting to the host controller and the motor drive.
	AO, /AO, BO, /BO	Line driver pulse output signal (Line Driver RS422) Max. output frequency: 150kHz Support frequency dividing output, the frequency dividing range: 1~31Hz.
TB1	VP	Power output of encoder Note: Use SW1 to set up output voltage Voltage: +5V±0.5V or +12V±1V Current: 200mA max
	0V	Common power terminal of encoder
	A、 \bar{A} 、B、 \bar{B} 、Z、 \bar{Z}	Incremental encoder signal input terminal Types of input signal: line drive, voltage output, push-pull, open-collector) Note: Different input signal needs different wiring method. See user manual for wiring diagrams. Max.input frequency: 150kHz
	U、 \bar{U} 、V、 \bar{V} 、W、 \bar{W}	Absolute encoder signal input terminal Types of input signal: : line drive, voltage, push-pull, open-collector) Note: Different input signal needs different wiring method. See user manual for wiring diagrams Max.input frequency: 150kHz
JP1		Ground Terminal Connect the power supply of the motor drive to the ground. Support PG shielding
	SW1	Switch between encoder's 5V/12V power.
	SW2	Offline Detection Switch. Switch the the SW2 to Line-D side to enable offline detection when Line-D input signal. Switch the SW2 to OPEN-C side to disable offline detection function when OPEN-C input signal.
	SW3	Switch of power supply for frequency division Switch SW3 to INP_sied to provide 24V power for internal use. Switch SW3 to EXP side to provide 24V power for external use (client).

Applicable encoders:

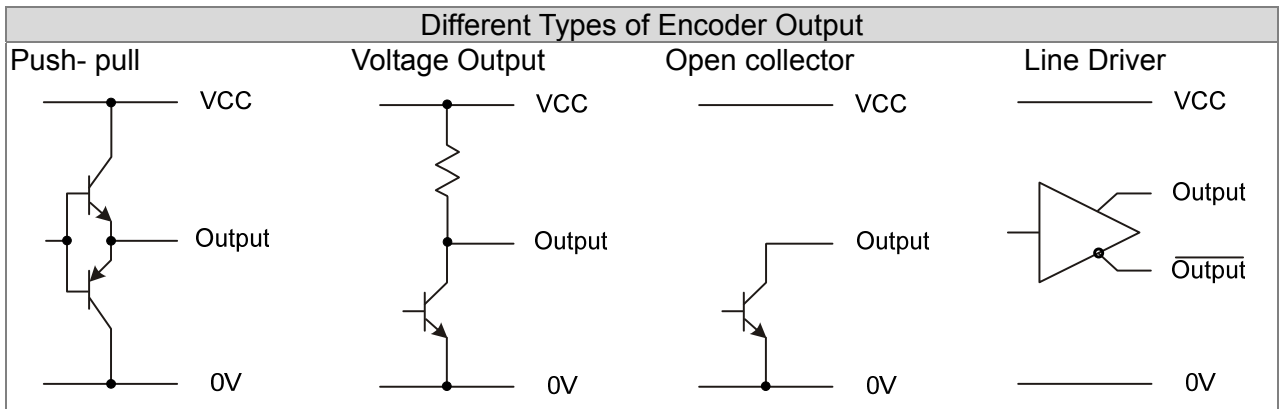

NOTE

- Verify if the SW1 is set to the correct output voltage before power on.
- Keep away from any high voltage line when wiring the motor drive to avoid interference

Wiring Diagram

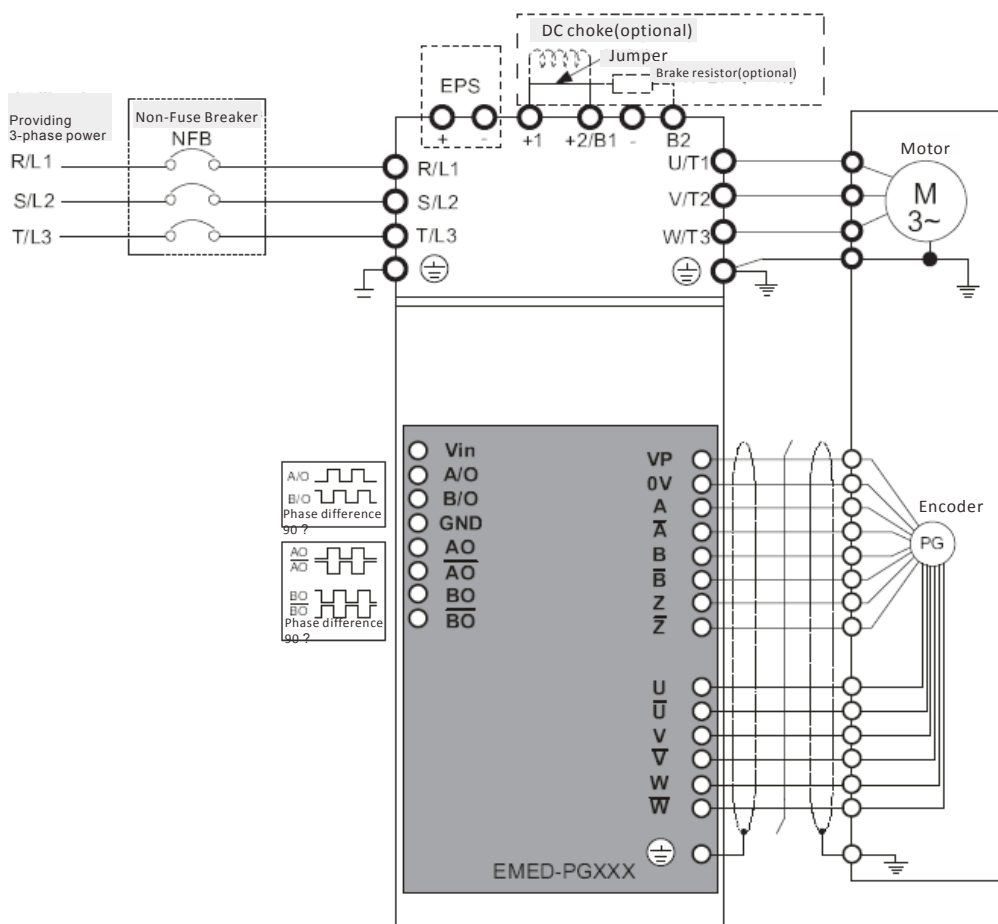

Set up the Signal of the Frequency Division

- ① After the encoder input a PULSE signal, there will be an output signal of the division factor “n.” Use Pr10-29 <Output of PG card’s frequency division> to set up.
- ② Setup of Pr10-29 <PG card’s frequency division>:
Output of decimal frequency division setting. Range of the division factor “n”: 1~31.
- ③ Pr10-30 <Mode of output of PG card’s frequency division>

Bit3	Bit2	Bit1	Bit0
X	X	OUT/M	IN/M

OUT/M: Mode of pulse output of frequency division;

IN/M: Mode of pulse input of frequency division;

“X” is for backup while “0” is a value to write.

Setting and Description of Input Mode (IN/M) & Output Mode(OUT/M):

OUT/M	IN/M	Division factor	
		A is ahead of B	B is ahead of A
0	0		
1	0		
X	1		

NOTE

- In the waveform A-/A, B-/B are the PG card input signals; AO- \overline{AO} , BO- \overline{BO} are the differential output frequency division signals. (Use a differential probe to measure.)
- Division factor “n”: Set 15 to have the input signal divided by 15.)
- When OUT/M, IN/M set as 0.0, the PG card input signal A-/A, B-/B are square waves while AO- \overline{AO} 、BO- \overline{BO} are frequency division output.
- When OUT/M, IN/M are set as 1.0, the PG card input signal A-/A、B-/B are square waves while the BO- \overline{BO} is the phase indicator of A and B
- When OUT/M, IN/M are set as X, B-/B phase has to be direction indication input signal (e.g. When B-/B is LOW, it means A is ahead of B. When B-/B is HIGH, it means B is ahead of A)
- Take Pr10-29 and Pr10-30 as examples. When frequency division value =1 5, OUT/M =1, IN/M = 0, set Pr10-29 = 15 and Pr10-30 = 0002h.
Set Pr100-29 =15,
Set Pr10-30 =0002h

Bit3	Bit2	Bit1	Bit0
X	X	1	0

7-2 EMED-PGHSD-1

Applicable enoder:

Sine-wave: Heidenhain ERN1387

EnDat2.1: Heidenhain EQN425, EQN1325, ECN113, ECN413, ECN1113, ECN1313

SICK HIPERFACE: SRS50/60

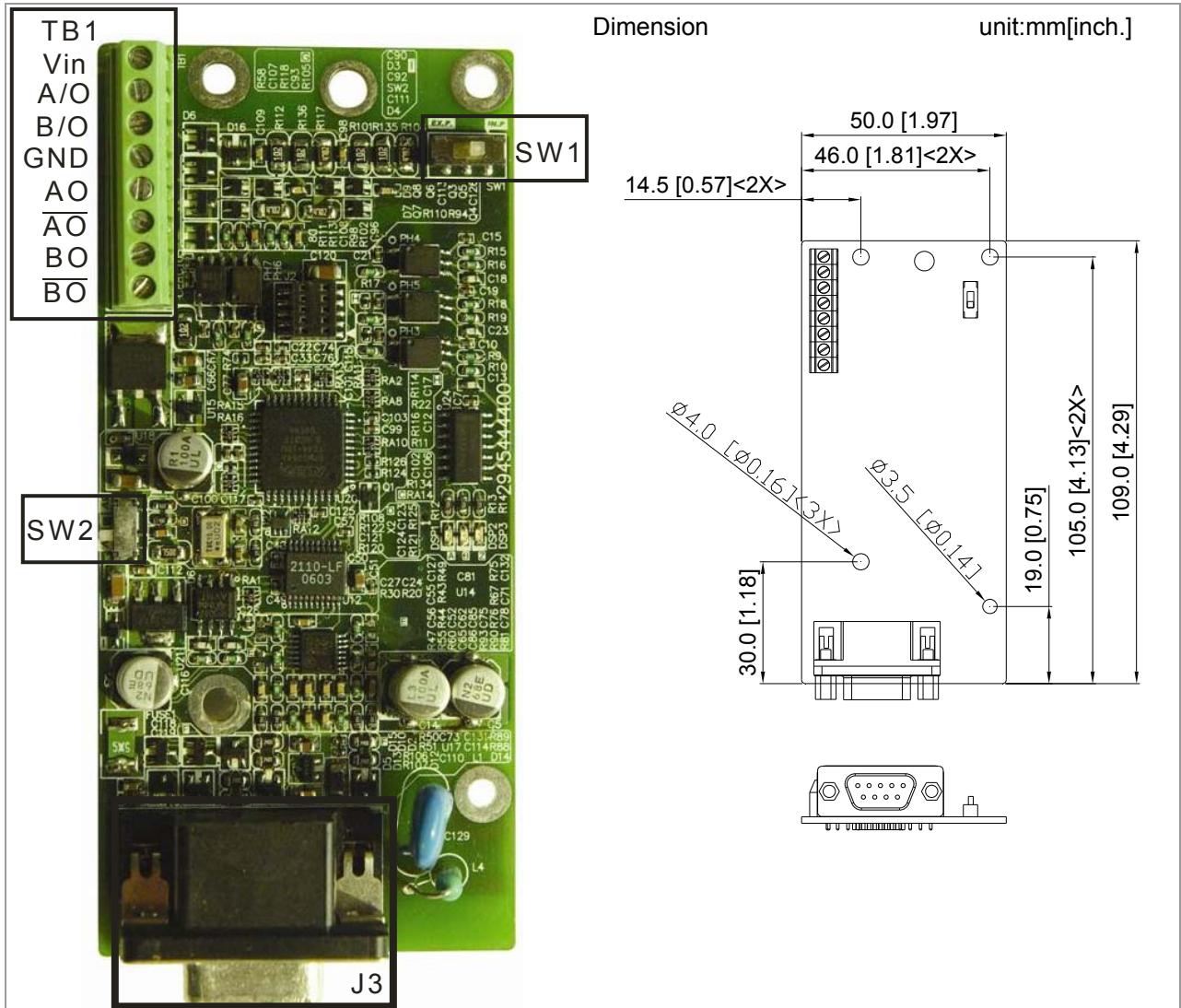

※ Support Heidenhain ERN1387, EnDat2.1, HIPERFACE

Terminals		Descriptions
TB1	Vin	Voltage Input: (to adjust output voltage amplitude of the push-pull pulse) Max. input voltage: 24VDC Max. input current: 30mA
	GND	Common power input/ signal output terminal
	A/O, B/O	(Push-Pull Voltage Output) Max. output frequency: 50kHz
	AO, /AO, BO, /BO	(Line Driver RS422) Max. input frequency: 100kHz
J3 (D-SUB female connector)		Encoder signal input terminal
SW1		Frequency divider output power terminal selection INP: Power supplied by PG card EXP: Power from external source
SW2		Frequency divider input power terminal selection 5V : 5Vdc 8V : 8Vdc

To use with Heidenhain ERN1387:

EMED-PGHSD-1 J3

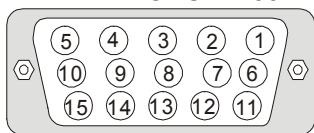

Heidenhain ERN1387

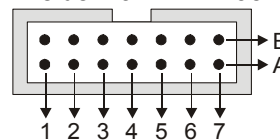

Terminal #	Terminals
1	B-
2	NC
3	Z+
4	Z-
5	A+
6	A-
7	0V
8	B+
9	VP
10	C+
11	C-
12	D+
13	D-
14	NC
15	NC

Terminal #	Terminals
5a	B-
-	-
4b	R+
4a	R-
6b	A+
2a	A-
5b	0V
3b	B+
1b	UP
1a	C-
7b	C+
2b	D+
6a	D-
-	-
-	-

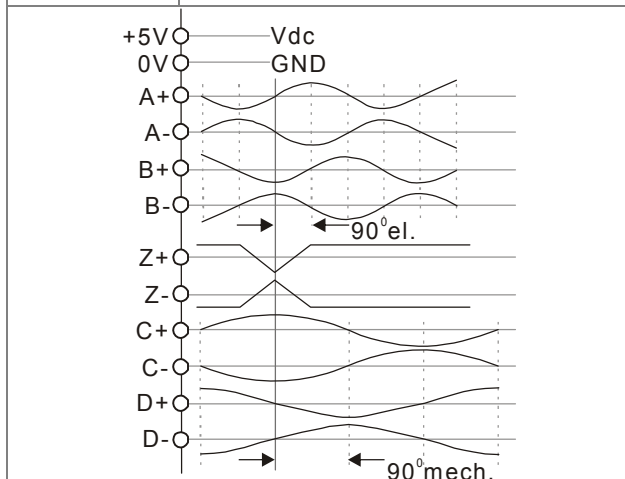

Terminal Function:

Terminals	Descriptions	Specifications	
VP	Encoder voltage input. Use SW2 to set +5V/+8V	Voltage: +5.1Vdc±0.3V; +8.4Vdc±1.5V Current: 200mA max.	
0V	Encoder common power terminal	Reference level of encoder's power.	
J3	A+ · A- · B+ · B- · Z+ · Z-	Encoder sine wave differential signal input (Incremental signal)	
	C+ · C- · D+ · D-	Encoder sine wave differential signal input (Absolute signal)	

Wiring Diagram

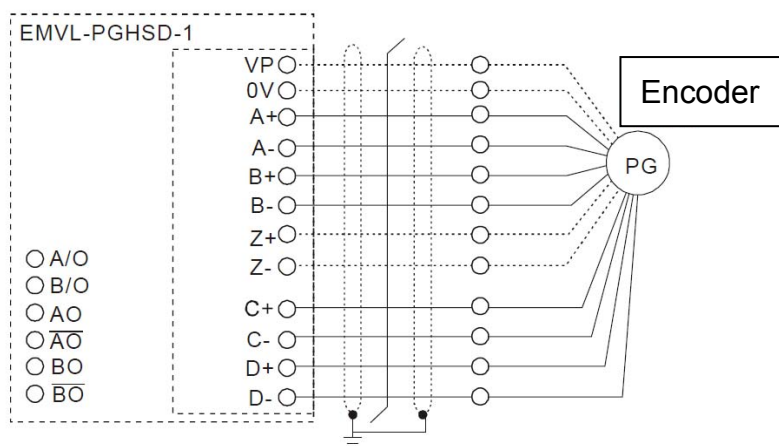

To use with Heidenhain EDat2.1/ SICK HIPERFACE:

EMED-PGHSD-1 J3	
Terminal #	Terminals
1	B-
2	-
3	Z+
4	Z-
5	A+
6	A-
7	0V
8	B+
9	VP
10	C+
11	C-
12	D+
13	D-
14	-
15	-

Heidenhain ECN1313	
Terminal#	Terminals
3b	B-
-	-
-	-
-	-
2a	A+
5b	A-
4b	0V
4a	B+
1b	+5V
2b	CLOCK+
5a	CLOCK-
6b	DATA+
1a	DATA-
-	-
-	-

SICK SRS 50/ SRS 60	
Terminal #	Terminals
3	REFSIN
-	-
-	-
-	-
8	+COS
4	REFCOS
2	GND
7	+SIN
1	+12V
-	-
-	-
5	DATA+
6	DATA-
-	-
-	-

Terminal Function:

Terminals	Descriptions	Specifications
VP	Encoder voltage input. Use SW2 to set +5V/+8V	Voltage: +5.1Vdc±0.3V; +8.4Vdc±1.5V Current: 200mA max.
0V	Encoder common power terminal	Reference level of encoder's power.
J3 A+、A-、B+、B-	Encoder sine wave differential signal input (Incremental signal)	Input frequency: 40k Hz max. 0.8...1.2V _{ss} (≈1V _{ss} ; Z ₀ =120Ω)
+SIN、+COS、REFSIN、REFCOS	Encoder sine wave differential signal input	Input frequency: 20k Hz max. 0.9...1.1V REFSIN/REFCOS
CLOCK+, CLOCK-	CLOCK differential output	(Line Driver RS422 Level output)
Data+, Data-	RS485 communication interface	Terminal resistance is about 130Ω

Wiring Diagram

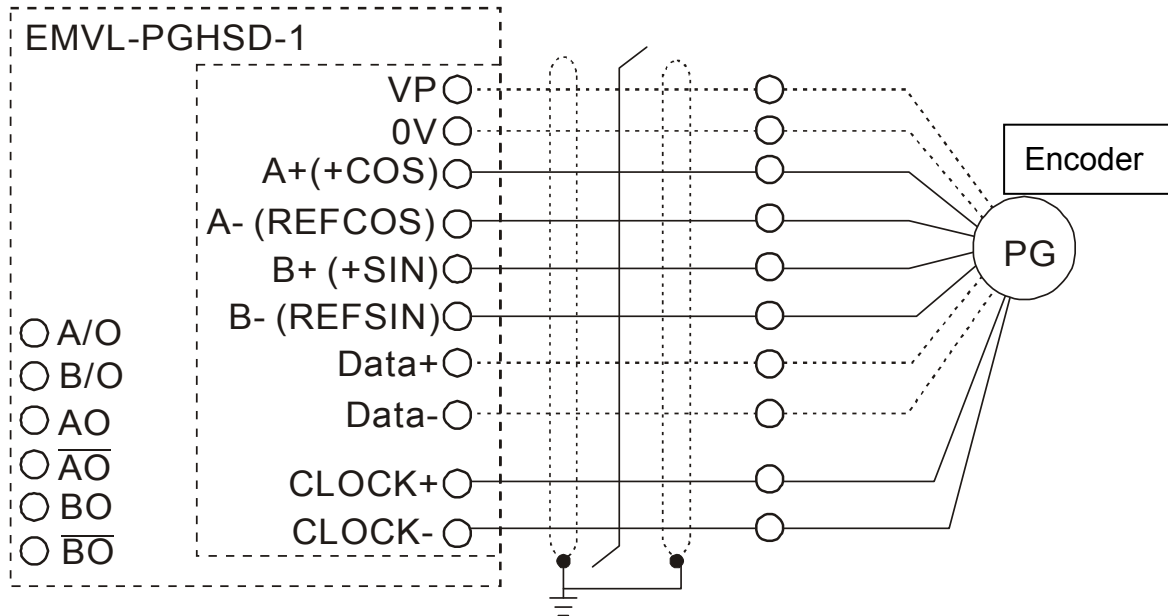

Set up the Signal of the Frequency Division

① After the encoder input a PULSE signal, there will be an output signal of the division factor “n.” Use Pr10-29 <Output of PG card’s frequency division> to set up.

② Pr10-30 <Mode of output of PG card’s frequency division>

Output of decimal frequency division setting. Range of the division factor “n”: 1~31.

③ Pr10-30 <Mode of output of PG card’s frequency division>

Bit3	Bit2	Bit1	Bit0
X	X	OUT/M	IN/M

OUT/M: Mode of pulse output of frequency division;

IN/M: Mode of pulse input of frequency division;

“X” is for backup while “0” is a value to write.

Setting and Description of Input Mode (IN/M) & Output Mode(OUT/M):

OUT/M	IN/M	Division factor			
		A is ahead of B	B is ahead of A		
0	0	A-/A		A-/A	
		B-/B		B-/B	
		AO-AO-bar		AO-AO-bar	
		BO-BO-bar		BO-BO-bar	
1	0	A-/A		A-/A	
		B-/B		B-/B	

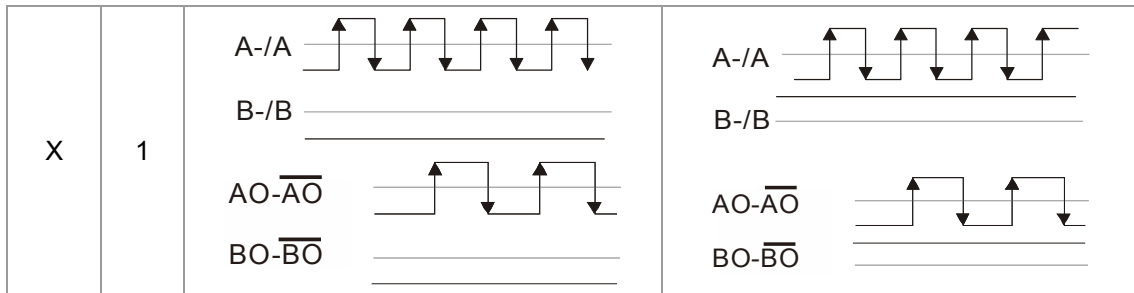
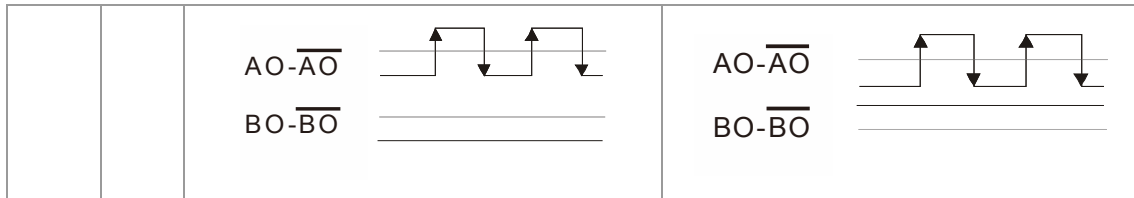

NOTE

- In the waveform A-/A, B-/B are the PG card input signals; AO- \overline{AO} , BO- \overline{BO} are the differential output frequency division signals. (Use a differential probe to measure.)
- Division factor "n": Set 15 to have the input signal divided by 15.)
- When OUT/M, IN/M set as 0.0, the PG card input signal A-/A, B-/B are square waves while AO- \overline{AO} 、BO- \overline{BO} are frequency division output.
- When OUT/M, IN/M are set as 1.0, the PG card input signal A-/A、B-/B are square waves while the BO- \overline{BO} is the phase indicator of A and B
- When OUT/M, IN/M are set as X, B-/B phase has to be direction indication input signal (e.g. When B-/B is LOW, it means A is ahead of When B-/B is HIGH, it means B is ahead of A)
- Take Pr10-29 and Pr10-30 as examples. when frequency division value =15, OUT/M =1, IN/M = 0, set Pr10-29 = 15 and Pr10-30 = 0002h.
Set Pr100-29 =15,
Set Pr10-30 =0002h

Bit3	Bit2	Bit1	Bit0
X	X	1	0

08 Specifications

230V Series

Frame Size		B			C			D			E	
Model VFD-__ _ED23/21S		022*	037*	040	055	075	110	150	185	220	300	370
Applicable Motor	Output(KW)	2.2	3.7	4.0	5.5	7.5	11	15	18.5	22	30	37
Applicable Motor	Output (HP)	3	5	5	7.5	10	15	20	25	30	40	50
Output Rating	Rated Output Capacity(KVA)	4.8	6.8	7.9	9.5	12.5	19	25	29	34	46	55
	Rated Output Current (A)	12.0	17	20.0	24.0	30.0	45.0	58.0	77.0	87.0	132.0	161.0
	Maximum Output Voltage (V)	3-phase Proportional to Input Voltage										
	Output Frequency	0.00~400Hz										
	Carrier Frequency	2~15kHz										2~9kHz
	Rated Output Maximum Carrier Frequency	8kHz			10kHz			8kHz			6kHz	
Input Rating	Input Current(A)	26	37.4	20	23	30	47	56	73	90	132	161
	Rated Voltage /Frequency	1-phase		3-phase								
	Voltage Tolerance	200~240V 50/60Hz										
	Frequency Tolerance	±10% (180~264V)										
Cooling Method	±5% (47~63Hz)											
Cooling Method		Fan cooled										
Weight (kg)		6	6	6	8	10	10	13	13	13	36	36

*VFD022ED21S & VFD037ED21S are 1-phase input models.

460V Series

Frame Size		B	C			D			E				
Model VFD-__ _ED43S		040	055	075	110	150	185	220	300	370	450	550	750
Applicable Motor Power(KW)		4.0	5.5	7.5	11	15	18.5	22	30	37	45	55	75
Applicable Motor power(HP)		5	7.5	10	15	20	25	30	40	50	60	75	100
Output Rating	Rated Output Capacity (KVA)	9.2	10.4	13.5	18.3	24	30.3	36	46.2	63.7	80	96.4	116.3
	Rated Output Current (A)	11.5	13	17	23	30	38	45	58	80	100	128	165
	Maximum Output Voltage(V)	3-phase Proportional to Input Voltage											
	Output Frequency	0.00~400Hz											
	Carrier Frequency	2~ 15kHz							2~ 9kHz		2~ 6kHz		
	Rated Output Maximum Carrier Frequency	8kHz	10kHz			8kHz			6kHz				
Input Rating	Rated Input Current(A)	11.5	14	17	24	30	37	47	58	80	100	128	165
	Rated voltage	3-phase 380~480V · 50/60Hz											
	Voltage Tolerance	±10% (342~528V)											
	Frequency Tolerance	±5% (47~63Hz)											
Cooling Method		Fan cooled											
Weight (kg)		6	8	10	10	10	10	13	14.5	36	36	50	50

*Assumes operation at the rated output. Input current rating varies depending on the power supply, input reactor, wiring connections and power supply impedance.

General Specifications

Control Characteristics	Control Method	1: V/F, 2: VF+PG, 3: SVC, 4: FOC+PG, 5: TQC+PG, 6:FOC+PM
	Starting Torque	Reach up to 150% or above at 0.5H Under FOC+PG or FOC+PM mode, starting torque can reach 150% at 0Hz.
	Speed Control Range	1:100(up to 1:1000 when using PG card)
	Speed Control Resolution	±0.5%(up to ±0.02% when using PG card)
	Speed Response Ability	5Hz(Up to 30Hz for vector control)
	Max. Output Frequency	0.00 to 400Hz
	Output Frequency Accuracy	Digital Command 0.005%, Analog Command 0.5%
	Frequency Setting Resolution	Digital Command 0.01Hz, Analog Command: 1/4096(12 bit) of the max. output frequency.
	Torque limit	Max. is 200% torque current
	Torque Accuracy	±5%
	Accel/ Decel Time	0.00~600.00 seconds
	V/F Curve	Adjustable V/f curve using 4 independent points and square curve.
	Frequency Setting Signal	±10V
	Brake Torque	About 20%
Protection Characteristics	Motor Protection	Electronic thermal relay protection.
	Over-current Protection	The current forces 200% of the over-current protection and 250% of the rated current.
	Ground Leakage Current Protection	Higher than 50% rated current
	Overload Ability	Constant torque: 150% for 60 seconds, variable torque: 200% for 3 seconds
	Over-voltage Protection	Over-voltage level: Vdc > 400/800V; low-voltage level: Vdc < 200/400V
	Over-voltage Protection for the Input Power	Varistor (MOV)
	Over-temperature Protection	Built-in temperature sensor
Environment	Protection Level	NEMA 1/IP20
	Operation Temperature	-10°C~40°C, Up to 50°C under derating operation
	Storage Temperature	-20°C~60°C
	Ambient Humidity	90% RH以下 (non- condensing)
	Vibration	1.0G less than 20Hz, 0,6G at 20~60 Hz
	Installation Location	Altitude 1,000m or lower, keep from corrosive gasses, liquid and dust.
	Power System	TN System ^{*1*2}
Certifications	 (UL mark excludes VFD022ED21S and VFD037ED21S)	

*1: TN system: The neutral point of the power system connects to the ground directly. The exposed metal components connect to the ground via the protective earth conductor.

*2: Single phase models use single phase three wire power system.





09 Digital Keypad

9-1 Descriptions of Digital keypad



Digital Operation Panel KPED-LE01











Function of Buttons

Buttons	Description
	Horizontal movement button: To move the cursor position for value adjustment.
	Reset the the motor drive after fault occurred.
	Change between different diplay mode.
	Parameter setting button: To read or modify various parameter settings.
	<ol style="list-style-type: none"> Two buttons available: Up and Down button Press Up or Down button to increase or decrease the value of a number. Press Up or Down button to choose between menus and languages.

LED Display

LED	Description
	Status Display: UP: Moving up. DN: Moving down D1: MI1 status D2: MI2 status D3: MI3 status D4: MI4 status
	Main Display Area: To display frequency, current, voltage, rotaion direction, user defined units, errors and warnings.

Description of the Displayed Functions

Displayed Function	Description
	Display the frequency setting of the VFD-ED
	Display the actual frequency delivered from VFD-ED to the motor.
	Display the user defined value at Pr00-04.
	Display the current (ampere)
	Display the selected parameter
	Display the value set at a parameter
	Display the external fault
	Display "End" for approximately 1 second if input has been accepted by pressing ENTER key. After a parameter value has been set, the new value is automatically stored in the register. To modify an entry, use the ▲ and ▼ keys.
	If the command given by the user is not accepted or the value of the command exceeds the allowed range, this error message will be displayed.

9-2 Operating the Built-in Digital Keypad

Setting Mode

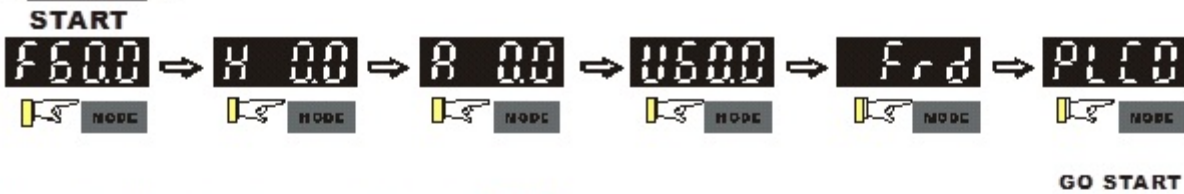

NOTE: In the selected mode, press **ENTER** to set the parameters.

Setting parameters



NOTE: In the parameter setting mode, you can press **ENTER** to the selected mode.

To change data



Setting direction (When operation source is digital keypad)



9-3 Description of the Digital Keypad KPC-CC01

KPC-CC01









Communication Interface
RJ-45 (socket), -485 interface;



Installation Method

1. Embedded type and can be put flat on the surface of the control box. The front cover is water proof.
2. Buy a MKC-KPPK model to do wall mounting or embedded mounting. Its protection level is IP66.
3. The maximum RJ45 extension lead is 5 m (16ft)
4. This keypad can also be used on Delta's motor drive C2000, CH2000 and CP2000.

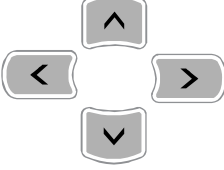
Function of Buttons

Button	Description
	Start Operation Key <ol style="list-style-type: none"> 1. It is only valid when the source of operation command is from the keypad. 2. It can operate the AC motor drive by the function setting and the RUN LED will be ON. 3. It can be pressed repeatedly while the motor drive is shutting down..
	Stop Command Key. This key has the highest processing priority in any situation. <ol style="list-style-type: none"> 1. When it receives STOP command, no matter the AC motor drive is in operation or stop status, the AC motor drive needs to execute "STOP" command. 2. The RESET key can be used to reset the drive after the fault occurs. For those faults that can't be reset by the RESET key, see the fault records after pressing MENU key for details.
	Operation Direction Key <ol style="list-style-type: none"> 1. This key is only control the operation direction NOT for activate the drive. FWD: forward, REV: reverse. 2. Refer to the LED descriptions for more details.
	ENTER Key Press ENTER and go to the next level. If it is the last level then press ENTER to execute the command
	ESCAPE Key ESC key function is to leave current menu and return to the last menu. It is also functioned as a return key in the sub-menu.
	Press menu to return to main menu.
	Direction: Left/Right/Up/Down <ol style="list-style-type: none"> 1. In the numeric value setting mode, it is used to move the cursor and change the numeric value. 2. In the menu/text selection mode, it is used for item selection.

Description of LED Functions

LED	Description
	<p>Steady ON: operation indicator of the AC motor drive, including DC brake, zero speed, standby, restart after fault and speed search.</p> <p>Blinking: drive is decelerating to stop or in the status of base block.</p> <p>Steady OFF: drive doesn't execute the operation command</p>
	<p>Steady ON: stop indicator of the AC motor drive.</p> <p>Blinking: drive is in the standby status.</p> <p>Steady OFF: drive doesn't execute "STOP" command.</p>
	<p>Operation Direction LED</p> <ol style="list-style-type: none"> 1. Green light is on, the drive is running forward. 2. Red light is on, the drive is running backward. 3. Twinkling light: the drive is changing direction.

9-4 Function of Digital Keypad KPC-CC01

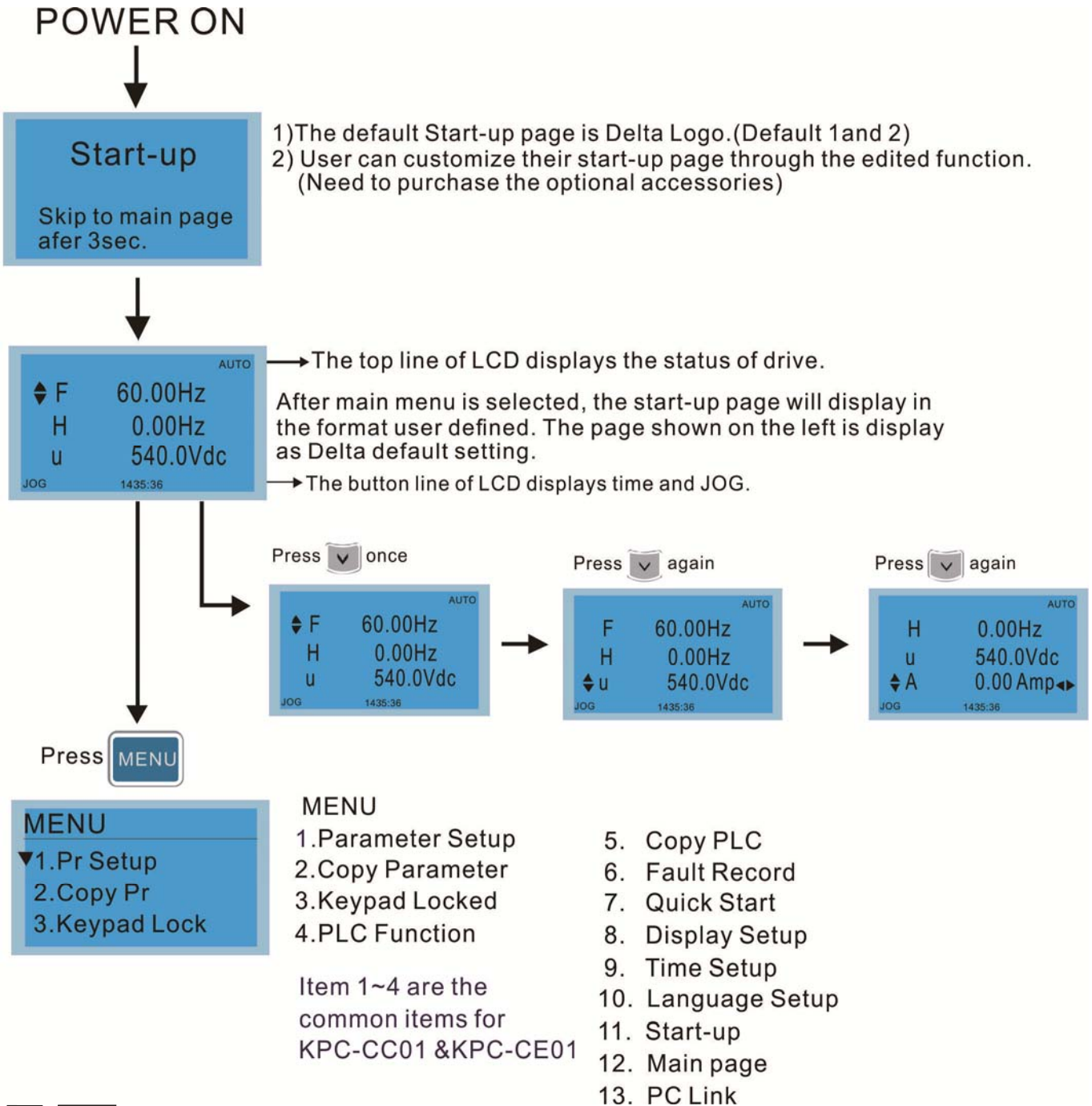

NOTE

1. Start-up page can only display pictures, no flash.
2. When Power ON, it will display startup page then the main page. The main page displays Delta's default setting F/H/A/U, the display order can be set by Pr.00.03 (Startup display). When the selected item is U page, use left key and right key to switch between the items, the display order of U page is set by Pr.00.04 (User display).
3. **VFD-ED doesn't support Function 3, 4 and 5.**

Display Icon

Start-up

◆ 1.Default 1 ●

2.Default 2

3.User define

● : present setting

◆ : roll down the page for more options

Press for more options.

Pr setup

◆ 00:SYSTEM PARAM

01:BASIC PARAM

02:DIGITAL IN/ ▶

▶ : show complete sentence

Press for complete information

Display Item

MENU

◆ 1.Pr Setup

2.Copy Pr

3.Keypad Lock

MENU

- 1.Parameter Setup
- 2.Copy Parameter
- 3.Keypad Locked
- 4.PLC Function
- 5. Copy PLC
- 6. Fault Record
- 7. Quick Start
- 8. Display Setup
- 9. Time Setup
- 10. Language Setup
- 11. Start-up
- 12. Main page
- 13. PC Link

Item 1~4 are the common items for KPC-CC01 &KPC-CE01

1. Parameter Setup





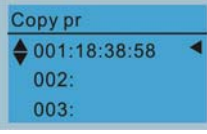

<div style="border: 1px solid black; padding: 5px; margin-bottom: 10px;"> <p>Pr setup</p> <p>◆ 00:SYSTEM PARAM</p> <p>01:BASIC PARAM</p> <p>02:DIGITAL IN/ ▶</p> </div> <p>Press to select.</p> <p>Press to select a parameter group.</p> <p>Once a parameter group is selected, press to go into that group.</p>	<p>For example: Setup source of master frequency command.</p> <div style="border: 1px solid black; padding: 5px; margin-bottom: 5px;"> <p>00- SYSTEM PARAME</p> <p>◆ 00: Identity Co ▶</p> <p>01: Rated Curren</p> <p>02: Parameter Re</p> </div> <p>Once in the Group 00 Motor Drive Parameter, Use Up/Down key to select parameter 20: Auto Frequency Command.</p> <div style="border: 1px solid black; padding: 5px; margin-bottom: 5px;"> <p>00- SYSTEM PARAME</p> <p>◆ 20: Source of F ▶</p> <p>21: Source of OP</p> <p>22: Stop Methods</p> </div> <p>When this parameter is selected, press ENTER key to go to this parameter's setting menu.</p> <div style="border: 1px solid black; padding: 5px; margin-bottom: 5px;"> <p>00-20</p> <p style="text-align: center;">2</p> <p>Analog Input</p> <p>0~8 ADD</p> </div> <p>Use Up/Down key to choose a setting. For example: Choose "2 Analogue Input, then press the ENTER key.</p> <div style="border: 1px solid black; padding: 5px;"> <p>00-20</p> <p style="text-align: center;">END</p> <p>Analog Input</p> </div> <p>After pressing the ENTER key, an END will be displayed which means that the parameter setting is done.</p>
--	--

2. Copy Parameter



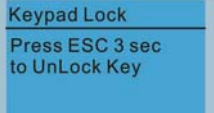

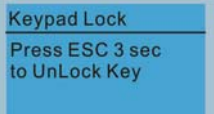
	<p>4 duplicates are provided The steps are shown in the example below. Example: Saved in the motor drive.</p>				
<p>Press ENTER key to go to 001~004: content storage</p>	<table border="1"> <tr> <td data-bbox="719 264 935 387"> </td> <td data-bbox="954 264 1492 387"> <p>1 Go to Copy Parameter 2 Select the parameter group which needs to be copied and press ENTER key.</p> </td> </tr> <tr> <td data-bbox="719 398 935 504"> </td> <td data-bbox="954 414 1500 504"> <p>1 Select 1: Save in the motor drive. 2. Press ENTER key to go to "Save in the motor drive" screen.</p> </td> </tr> </table>		<p>1 Go to Copy Parameter 2 Select the parameter group which needs to be copied and press ENTER key.</p>		<p>1 Select 1: Save in the motor drive. 2. Press ENTER key to go to "Save in the motor drive" screen.</p>
	<p>1 Go to Copy Parameter 2 Select the parameter group which needs to be copied and press ENTER key.</p>				
	<p>1 Select 1: Save in the motor drive. 2. Press ENTER key to go to "Save in the motor drive" screen.</p>				
	<table border="1"> <tr> <td data-bbox="719 533 935 656"> </td> <td data-bbox="954 589 1444 622"> <p>Begin to copy parameters until it is done.</p> </td> </tr> </table>		<p>Begin to copy parameters until it is done.</p>		
	<p>Begin to copy parameters until it is done.</p>				
	<table border="1"> <tr> <td data-bbox="719 667 935 779"> </td> <td data-bbox="954 689 1500 757"> <p>Once copying parameters is done, keypad will automatically be back to this screen.</p> </td> </tr> </table>		<p>Once copying parameters is done, keypad will automatically be back to this screen.</p>		
	<p>Once copying parameters is done, keypad will automatically be back to this screen.</p>				
	<p>Example: Saved in the keypad.</p>				
	<table border="1"> <tr> <td data-bbox="719 853 935 976"> </td> <td data-bbox="954 853 1500 976"> <p>1. Once copying parameters is done, keypad will automatically be back to this screen. 2. Select the parameter group which needs to be copied and press ENTER key.</p> </td> </tr> </table>		<p>1. Once copying parameters is done, keypad will automatically be back to this screen. 2. Select the parameter group which needs to be copied and press ENTER key.</p>		
	<p>1. Once copying parameters is done, keypad will automatically be back to this screen. 2. Select the parameter group which needs to be copied and press ENTER key.</p>				
	<table border="1"> <tr> <td data-bbox="719 999 935 1111"> </td> <td data-bbox="954 1021 1500 1088"> <p>Press ENTER key to go to "Save in the motor drive" screen.</p> </td> </tr> </table>		<p>Press ENTER key to go to "Save in the motor drive" screen.</p>		
	<p>Press ENTER key to go to "Save in the motor drive" screen.</p>				
	<table border="1"> <tr> <td data-bbox="719 1133 935 1245"> </td> <td data-bbox="954 1155 1500 1245"> <p>Use Up/Down key to select a symbol. Use Left/Right key to move the cursor to select a file name.</p> </td> </tr> </table>		<p>Use Up/Down key to select a symbol. Use Left/Right key to move the cursor to select a file name.</p>		
	<p>Use Up/Down key to select a symbol. Use Left/Right key to move the cursor to select a file name.</p>				
	<p>String & Symbol Table: !"#\$%&'()*+,-./0123456789:;<=>?@ABCDEFGHIJKLMN OPQRSTUVWXYZ [\] ^ _ ` a b c d e f g h i j k l m n o p q r s t u v w x y z { } ~</p>				
	<table border="1"> <tr> <td data-bbox="719 1447 935 1559"> </td> <td data-bbox="954 1480 1500 1547"> <p>Once the file name is confirmed, press ENTER key.</p> </td> </tr> </table>		<p>Once the file name is confirmed, press ENTER key.</p>		
	<p>Once the file name is confirmed, press ENTER key.</p>				
	<table border="1"> <tr> <td data-bbox="719 1581 935 1715"> </td> <td data-bbox="954 1637 1484 1671"> <p>To begin copying parameters until it is done.</p> </td> </tr> </table>		<p>To begin copying parameters until it is done.</p>		
	<p>To begin copying parameters until it is done.</p>				
	<table border="1"> <tr> <td data-bbox="719 1738 935 1850"> </td> <td data-bbox="954 1749 1500 1850"> <p>When copying parameters is completed, keypad will automatically be back to this screen.</p> </td> </tr> </table>		<p>When copying parameters is completed, keypad will automatically be back to this screen.</p>		
	<p>When copying parameters is completed, keypad will automatically be back to this screen.</p>				
	<table border="1"> <tr> <td data-bbox="719 1872 935 1995"> </td> <td data-bbox="954 1906 1500 1973"> <p>Press Right key to see the date of copying parameters.</p> </td> </tr> </table>		<p>Press Right key to see the date of copying parameters.</p>		
	<p>Press Right key to see the date of copying parameters.</p>				

		<p>Press Right key to see the time of copying parameters.</p>
--	---	---

3. Lock the Keypad



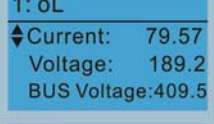

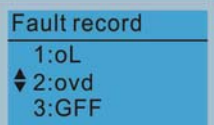
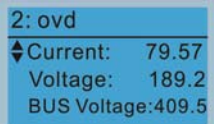
<p>Keypad Lock</p> <p>Press ENTER to Lock Key</p>	<p>Keypad Locked</p> <p>This function is used to lock the keypad. The main page would not display "keypad locked" when the keypad is locked, however it will display the message "please press ESC and then ENTER to unlock the keypad" when any key is pressed.</p>
<p>Press  to lock</p>	<p> AUTO ♦F 60.00Hz H 0.00Hz u 540.0Vdc JOG 14:35:58</p> <p>When the keypad is locked, the main screen doesn't display any status to show that.</p>
	<p> Keypad Lock Press ESC 3 sec to UnLock Key</p> <p>Press any key on the keypad; a screen as shown in image on the left will be displayed.</p>
	<p> AUTO ♦F 60.00Hz H 0.00Hz u 540.0Vdc JOG 14:35:58</p> <p>If ESC key is not pressed, the keypad will automatically be back to this screen.</p>
	<p> Keypad Lock Press ESC 3 sec to UnLock Key</p> <p>The keypad is still locked at this moment. By pressing any key, a screen as shown in the image on the left will still be displayed.</p>
	<p> AUTO ♦F 60.00Hz H 0.00Hz u 540.0Vdc JOG 14:35:58</p> <p>Press ESC for 3 seconds to unlock the keypad and the keypad will be back to this screen. Then each key on the keypad is functional.</p>
	<p>Turn off the power and turn on the power again will not lock keypad.</p>

4. Fault Record

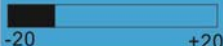

<p>Fault record</p> <p>▼ 1:oL 2:ovd 3:GFF</p>	<p>Able to store 6 error code (Keypad V1.02 and previous versions) Able to store 20 error code(Keypad V1.0e3 and previous version) The most recent error record is shown as the first record. Select an error record to see its detail such as date, tme, frequency, current, voltage, DCBUS voltage)</p>
<p>Press  to select.</p>	<p> Fault record ▼ 1:oL 2:ovd 3:GFF</p> <p>Press Up/Down key to select an error record. After selecting an error code, press ENTER to see that error record's detail</p>
<p>KPC-CE01 does not support this function.</p>	<p> 1: oL ♦Current: 79.57 Voltage: 189.2 BUS Voltage:409.5</p> <p>Press Up/Down key to see an error record's detail such as date, time, frequency, current, voltage, DCBus voltage.</p>
	<p> 1: oL ♦Date: 01/20/2014 Time: 21:02:24 Outfreq: 32.61</p>
	<p> Fault record 1:oL ♦ 2:ovd 3:GFF</p> <p>Press Up/Down key to select an error record. After selecting an error code, press ENTER to see that error record's detail</p>
	<p> 2: ovd ♦Current: 79.57 Voltage: 189.2 BUS Voltage:409.5</p> <p>Press Up/Down key to see an error record's detail such as date, time, frequency, current, voltage, DCBus voltage.</p>

	<div style="border: 1px solid black; padding: 5px; margin-bottom: 5px;"> 2: ovd ◆Date: 01/20/2014 Time: 21:02:24 Outfreq: 32.61 </div> <div style="border: 1px solid black; padding: 5px;">  NOTE Fault actions of AC motor drive are record and save to KPC-CC01. When KPC-CC01 is removed and apply to another AC motor drive, the previous fault records will not be deleted. The new fault records of the present AC motor drive will accumulate to KPC-CC01. </div>
--	--

5. Display Setup

<div style="border: 1px solid black; padding: 5px; margin-bottom: 10px;"> Displ Setup ▼1:Contrast 2:Back-Light 3:Text Color </div> <p>Press  to setting menu.</p>	<p>1. Contrast</p> <div style="border: 1px solid black; padding: 5px; margin-bottom: 5px;"> Contrast +0  -20 +20 </div> <p>Use Up/Down key to adjust the setting value.</p> <div style="border: 1px solid black; padding: 5px; margin-bottom: 5px;"> Contrast +10  -20 +20 </div> <p>After selecting a setting value. Press ENTER to see screen's display after contrast is adjusted to be +10.</p> <div style="border: 1px solid black; padding: 5px; margin-bottom: 5px;"> Displ Setup ▼1:Contrast 2:Back-Light 3:Text Color </div> <p>When the setting value is 0 Min, the back light will be steady on.</p> <div style="border: 1px solid black; padding: 5px; margin-bottom: 5px;"> Contrast -10  -20 +20 </div> <p>Then press ENTER.</p> <div style="border: 1px solid black; padding: 5px;"> Displ Setup ▼1:Contrast 2:Back-Light 3:Text Color </div> <p>After select a setting value Press ENTER to see screen's display result after contrast is adjusted to be -10.</p> <p>2. Back-light</p> <div style="border: 1px solid black; padding: 5px; margin-bottom: 5px;"> Displ Setup 1:Contrast ◆2:Back-Light 3:Text Color </div> <p>Press ENTER to go to Back Light Time Setting screnn.</p> <div style="border: 1px solid black; padding: 5px; margin-bottom: 5px;"> Back-Light Min 5  0 10 </div> <p>Use Up/Down key to adjust the setting value.</p> <div style="border: 1px solid black; padding: 5px; margin-bottom: 5px;"> Back-Light Min 0  0 10 </div> <p>When the setting value is 0 Min, the back light will be steady on.</p> <div style="border: 1px solid black; padding: 5px;"> Displ Setup 1:Contrast ◆2:Back-Light 3:Text Color </div> <p>When the setting value is 10 Min, the backlight will be off in 10 minutes.</p>
--	---

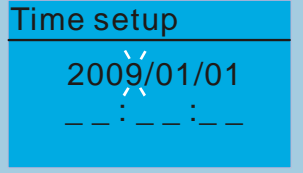
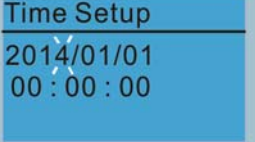
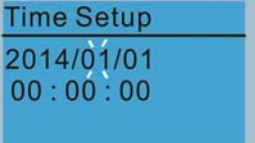
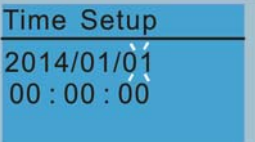
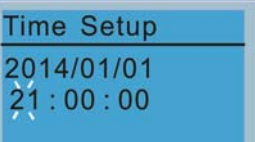
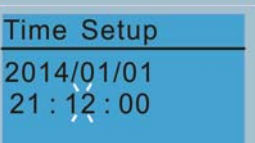
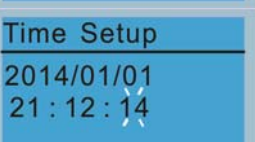
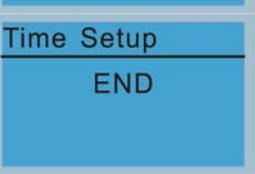

6. Time Setting

 <p>Use Left/Right key to select Year, Month, Day, Hour, Minute or Second to set up</p>	 <p>Use Up/Down key to set up Year</p>  <p>Use Up/Down key to set up Month</p>  <p>Use Up/Down key to set up day</p>  <p>Use Up/Down key to set up hour</p>  <p>Use Up/Down key to set up Minute</p>  <p>Use Up/Down key to set up Second</p>  <p>After setting up, press ENTER to confirm the setup.</p>
<p> NOTE</p> <p>When the digital keypad is removed, the time setting will be in standby status for 7 days. After this period, the time needs to be reset.</p>	

7. Language setup

 <p>Use Up/Down key to select language, than press ENTER.</p>	<p>Language setting option is displayed in the language of the user's choice.</p> <p>Language setting options:</p> <table border="0"> <tr> <td>1. English</td> <td>5.</td> </tr> <tr> <td>2. 繁體中文</td> <td>6. Espanol</td> </tr> <tr> <td>3. 简体中文</td> <td>7. Portugues</td> </tr> <tr> <td>4. Turkce</td> <td></td> </tr> </table>	1. English	5.	2. 繁體中文	6. Espanol	3. 简体中文	7. Portugues	4. Turkce	
1. English	5.								
2. 繁體中文	6. Espanol								
3. 简体中文	7. Portugues								
4. Turkce									

8. Startup

<p>Start-up</p> <ul style="list-style-type: none"> ▼ 1.Default 1 ● 2.Default 2 3.User Define 	<p>1. Default 1 DELTA LOGO</p>  <p>2. Default 2 DELTA Text</p>  <p>3. User Defined: optional accessory is require (TPEditor & USB/RS-485 Communication Interface-IFD6530)</p> <p>Install an editing accessory would allow users to design their own start-up page.If editor accessory is not installed, “user defined” option will display a blank page.</p>  <p><u>USB/RS-485 Communication Interface-IFD6530</u> Please refer to Chapter 07 Optional Accessories for more detail.</p> <p><u>TPEditor</u> Go to Delta’s website to download TPEditor V1.30.6 or later versions. http://www.delta.com.tw/ch/product/em/download/download_main.asp?act=3&pid=1&cid=1&tpid=3</p>
--	--

9. Mian Pge

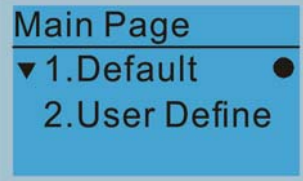

Default picture and editable picture are available upon selection.

Press  to select.

1. Default page

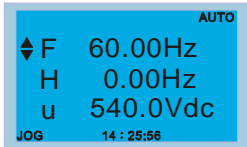

F 600.00Hz >>> H >>> A >>> U (circulate)

2. User Defined: optional accessory is require (TPEditor & USB/RS-485 Communication Interface-IFD6530)
Install an editing accessory would allow users to design their own start-up page.If editor accessory is not installed, "user defined" option will dispay a blank page.

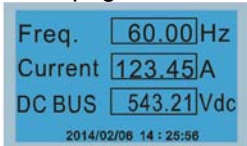
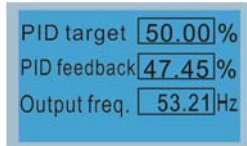
USB/RS-485 Communication Interface-IFD6530
Please refer to Chapter 07 Optional Acessories for more detail.

TPEditor
Go to Delta's website to download TPEditor V1.30.6 or later versions.
http://www.delta.com.tw/ch/product/em/download/download_main.asp?act=3&pid=1&cid=1&tpid=3

10. PC Link

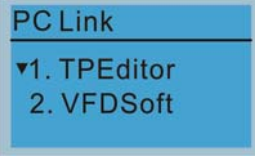

1. TPEditor: This function allows users to connect the keypad to a computer then to download and edit user defined pages.

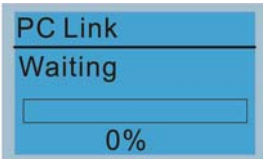

Click ENTER to go to <Waiting to connect to PC>

In TPEditor, choose <Communication>, then choose "Write to HMI"

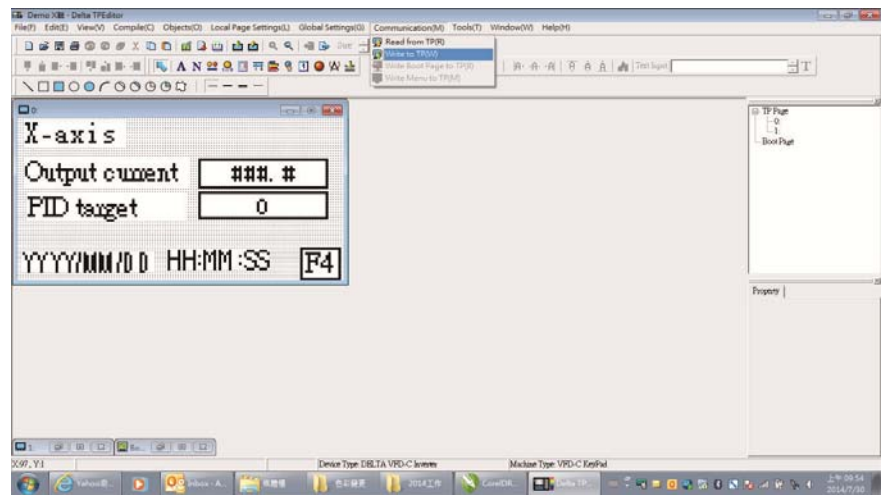

Choose <YES> in the <Confirm to Write> dialogue box.

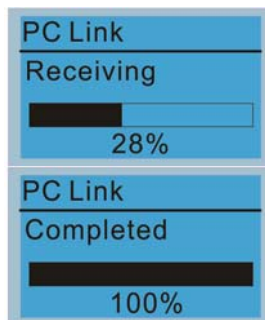
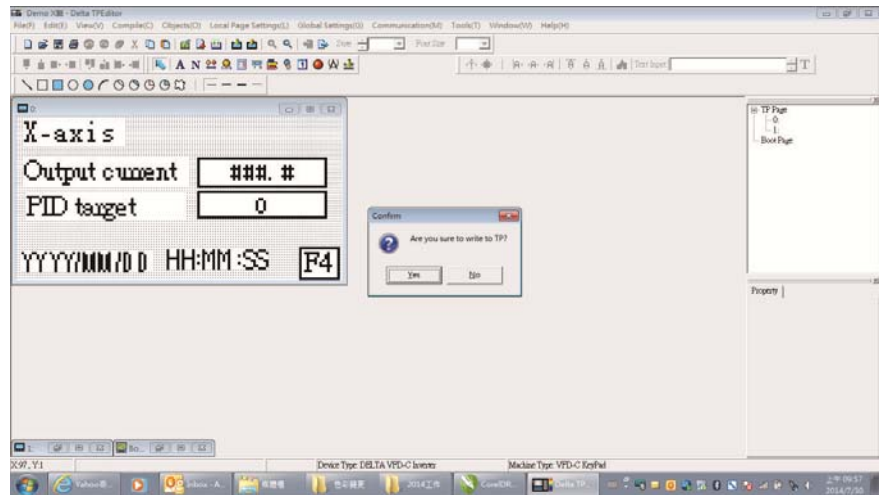

Start downloading pages to edit KPC-CC01.

Download completed

2. VFDSOft: this function allows user to link to the VFDSOft Operating software then to upload data
Copy parameter 1~4 in KPC-CC01
Connect KPC-CC01 to a computer

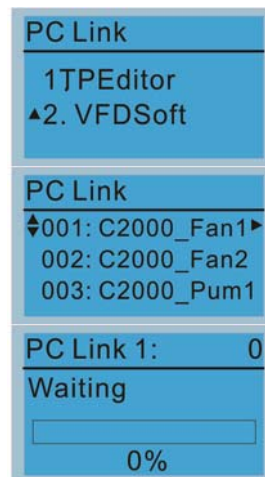

Start downloading pages to edit to KPC-CC01

Use Up/Down key to select a parameter group to upload to VFDSOft. Press ENTER

Waiting to connect to PC

Open VFDSOft, choose <Parameter Manager function>

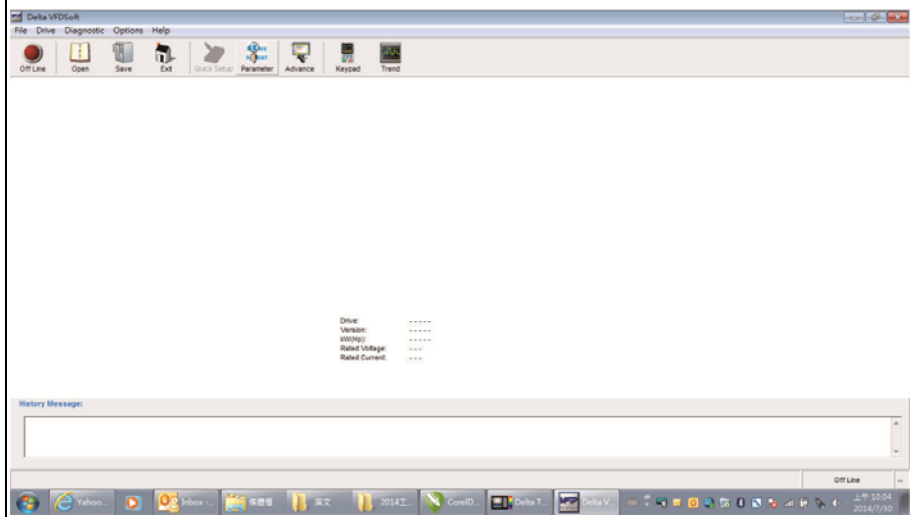

In Parameter Manager, choose <Load parameter table from KPC-CC01>

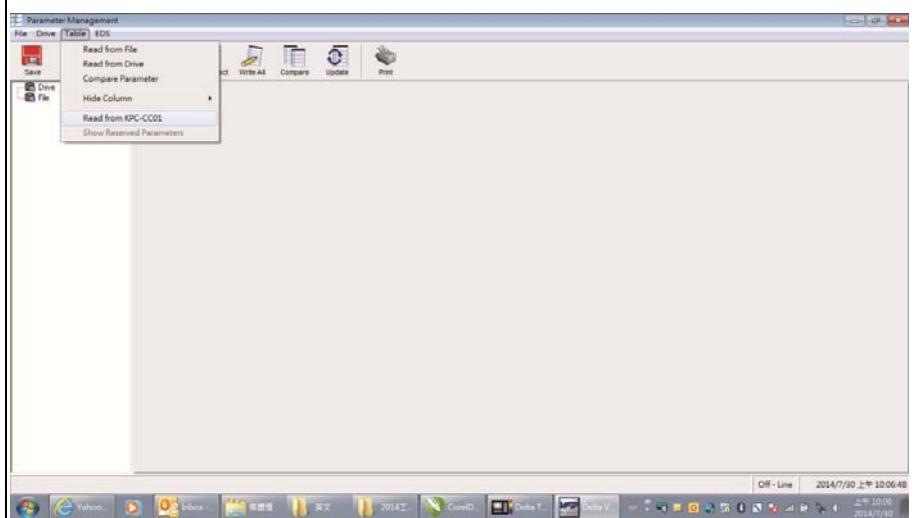

Choose the right communication port and click OK

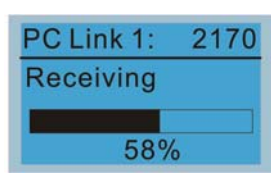
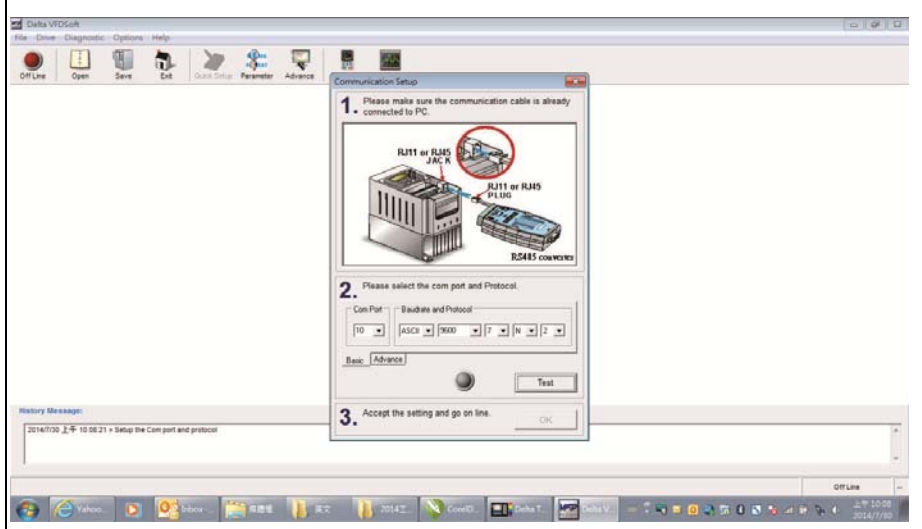

Start to upload parameters to VFDSOft

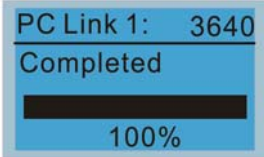
	 <p>Uploading parameter is completed</p> <p>Before using the user defined starting screen and user defined main screen, the starting screen setup and the main screen setup have to be preset as user defined.</p> <p>If the user defined page are not downloaded to KPC-CC01, the starting screen and the main screen will be blank.</p>
--	--

Other Display

When fault occur, the menu will display:

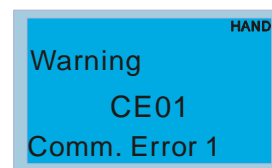
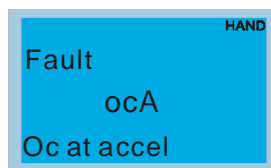

1. Press ENTER and start RESET. If still no response, please contact local distributor or return to the factory. To view the fault DC BUS voltage, output current and output voltage, press "MENU"→"Fault Record".
2. Press ENTER again, if the screen returns to main page, the fault is clear.
3. When fault or warning message appears, backlight LED will blinks until the fault or the warning is cleared.

Optional accessory: RJ45 Extension Lead for Digital Keypad

Part No.	Description
CBC-K3FT	RJ45 extension lead, 3 feet (approximately 0.9m)
CBC-K5FT	RJ45 extension lead, 5 feet (approximately 1.5 m)
CBC-K7FT	RJ45 extension lead, 7 feet (approximately 2.1 m)
CBC-K10FT	RJ45 extension lead, 10 feet (approximately 3 m)
CBC-K16FT	RJ45 extension lead, 16 feet (approximately 4.9 m)

Note: When you need to buy communication cables, buy non-shielded , 24 AWG, 4 twisted pair, 100 ohms communication cables.

9-5 Digital Keypad KPC-CC01 Fault Codes and Descriptions

Fault Codes:

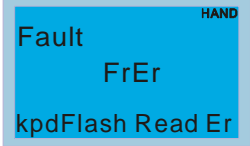
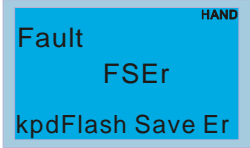
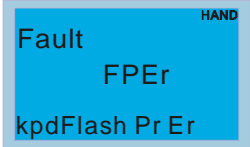
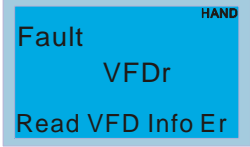
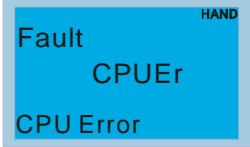
LCM Display *	Description	Corrective Actions
	Keypad flash memory read error	<p>An error has occurred on keypad's flash memory.</p> <ol style="list-style-type: none"> 1. Press RESET on the keypad to clear errors. 2. Verify what kind of error has occurred on keypad's flash memory. 3. Shut down the system, wait for ten minutes, and then power on again the system. <p>If none of the solution above works, contact your authorized local dealer.</p>
	Keypad flash memory save error	<p>An error has occurred on keypad's flash memory.</p> <ol style="list-style-type: none"> 1. Press RESET on the keypad to clear errors. 2. Press RESET on the keypad to clear errors. 3. Shut down the system, wait for ten minutes, and then power on again the system. <p>If none of the solution above works, contact your authorized local dealer.</p>
	Keypad flash memory parameter error	<p>Errors occurred on parameters of factory setting. It might be caused by firmware update.</p> <ol style="list-style-type: none"> 1. Press RESET on the keypad to clear errors. 2. Verify if there's any problem on Flash IC. 3. Shut down the system, wait for ten minutes, and then power on again the system. <p>If none of the solution above works, contact your local authorized dealer.</p>
	Keypad flash memory read AC drive data error	<p>Keypad can't read any data sent from VFD.</p> <ol style="list-style-type: none"> 1. Verify if the keypad is properly connect to the motor drive by a communication cable such as RJ-45. 2. Press RESET on the keypad to clear errors. 3. Shut down the system, wait for ten minutes, and then power on again the system. <p>If none of the solution above works, contact your local authorized dealer.</p>
	and then power on again the system.	<p>A Serious error has occurred on keypad's CPU.</p> <ol style="list-style-type: none"> 1. Verify if there's any problems on CPU clock? 2. Verify if there's any problem on Flash IC? 3. Verify if there's any problem on RTC IC? 4. Verify if the communication quality of the RS485 is good? 5. Shut down the system, wait for ten minutes, and then power on again the system. If none of the solution above works, contact your local authorized dealer.

Warning Codes:

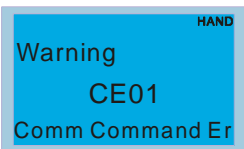
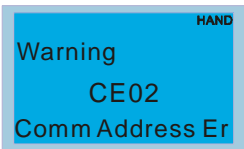
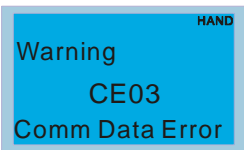
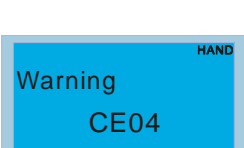
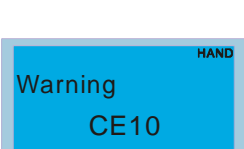
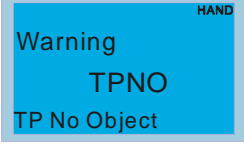
LCM Display *	Description	Corrective Actions
 <p>Warning CE01 Comm Command Er</p>	Modbus function code error	<p>Motor drive doesn't accept the communication command sent from keypad.</p> <ol style="list-style-type: none"> 1. Verify if the keypad is properly connected to the motor drive on the communication contact by a communication cable such as RJ-45. 2. Press RESET on the keypad to clear errors. <p>If none of the solution above works, contact your local authorized dealer.</p>
 <p>Warning CE02 Comm Address Er</p>	Modbus data address error	<p>Motor rive doesn't accept keypad's communication address.</p> <ol style="list-style-type: none"> 1. Verify if the keypad is properly connected to the motor drive on the communication contact by a communication cable such as RJ-45. 2. Press RESET on the keypad to clear errors. <p>If none of the solution above works, contact your local authorized dealer.</p>
 <p>Warning CE03 Comm Data Error</p>	Modbus data value error	<p>Motor drive doesn't accept the communication data sent from keypad.</p> <ol style="list-style-type: none"> 1. Verify if the keypad is properly connected to the motor drive on the communication contact by a communication cable such as RJ-45. 2. Press RESET on the keypad to clear errors. <p>If none of the solution above works, contact your local authorized dealer.</p>
 <p>Warning CE04 Comm Slave Error</p>	Modbus slave drive error	<p>Motor drive cannot process the communication command sent from keypad.</p> <ol style="list-style-type: none"> 1. Verify if the keypad is properly connected to the motor drive on the communication contact by a communication cable such as RJ-45. 2. Press RESET on the keypad to clear errors. 3. Shut down the system, wait for ten minutes, and then power on again the system. <p>If none of the solution above works, contact your local authorized dealer.</p>
 <p>Warning CE10 KpdComm Time Out</p>	Modbus transmission time-Out	<p>Motor drive doesn't respond to the communication command sent from keypad.</p> <ol style="list-style-type: none"> 1. Verify if the keypad is properly connected to the motor drive on the communication contact by a communication cable such as RJ-45. 2. Press RESET on the keypad to clear errors. 3. Shut down the system, wait for ten minutes, and then power on again the system. <p>If none of the solution above works, contact your local authorized dealer.</p>
 <p>Warning TPNO TP No Object</p>	Object not supported by TP Editor	<p>Keypad's TP Editor uses unsupported object.</p> <ol style="list-style-type: none"> 1. Verify how the TP editor should use that object. Delete unsupported object and unsupported setting. 2. Reedit the TP editor and then download it. <p>If none of the solution above works, contact your local authorized dealer.</p>

File Copy Setting Fault Description

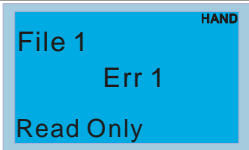
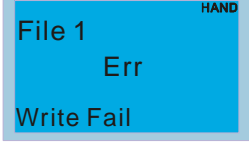
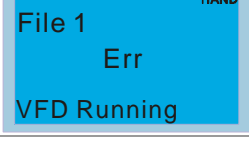
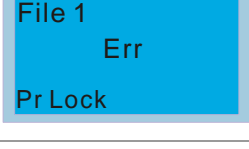
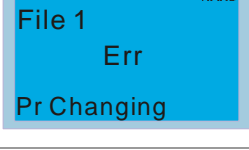
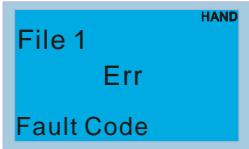
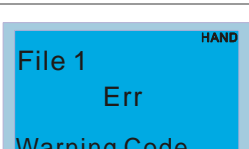
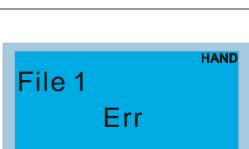
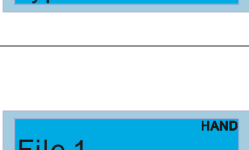
LCM Display *	Description	Corrective Actions
	Parameter and file are read only	The property of the parameter/file is read-only and cannot be written to. 1. Verify the specification on the user manual. If the solution above doesn't work, contact your local authorized dealer.
	Fail to write parameter and file	An error occurred while write to a parameter/file. 1. Verify if there's any problem on the Flash IC. 2. Shut down the system, wait for ten minutes, and then power on again the system. If none of the solution above work, contact your local authorized dealer.
	AC drive is in operating status	A setting cannot be made while motor drive is in operation. 1. Verify if the drive is not in operation. If the solution above doesn't work, contact your local authorized dealer.
	AC drive parameter is locked	A setting cannot be made because a parameter is locked. 1. Verify if the parameter is locked or not. If it is locked, unlock it and try to set up the parameter again. If the solution above doesn't work, contact your local authorized dealer.
	AC drive parameter changing	A setting cannot be made because a parameter is being modified. 1. Verify if the parameter is being modified. If it is not being modified, try to set up that parameter again. If the solution above doesn't work, contact your local authorized dealer.
	Fault code	A setting cannot be made because an error has occurred on the motor drive. 1. Verify if there's any error occurred on the motor drive. If there isn't any error, try to make the setting again. If the solution above doesn't work, contact your local authorized dealer.
	Warning code	A setting cannot be made because of a warning message given to the motor drive. 1. Verify if there's any warning message given to the motor drive. If the solution above doesn't work, contact your local authorized dealer.
	File type dismatch	Data need to be copied are not same type, so the setting cannot be made. 1. Verify if the products' serial numbers need to be copied fall in the category. If they are in the same category, try to make the setting again. If the solution above doesn't work, contact your authorized dealer.
	File is locked with password	A setting cannot be made, because some data are locked. 1. Verify if the data are unlocked or able to be unlocked. If the data are unlocked, try to make the setting again. 2. Shut down the system, wait for ten minutes, and then power on again the system. If none of the solution above works, contact your local authorized dealer.

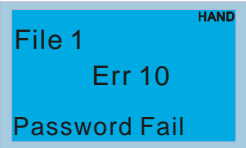
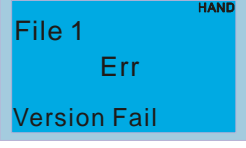
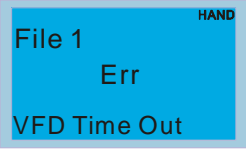
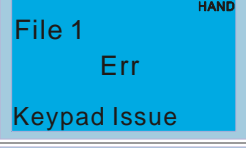
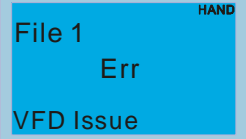
LCM Display *	Description	Corrective Actions
	File version mismatch	<p>A setting cannot be made because the password is incorrect.</p> <ol style="list-style-type: none"> 1. Verify if the password is correct. If the password is correct, try to make the setting again. 2. Shut down the system, wait for ten minutes, and then power on again the system. <p>If none of the solution above works, contact your local authorized dealer.</p>
	AC drive copy function time-out	<p>A setting cannot be made, because the version of the data is incorrect.</p> <ol style="list-style-type: none"> 1. Verify if the version of the data matches the motor drive. If it matches, try to make the setting again. <p>If none of the solution above works, contact your local authorized dealer.</p>
	Other keypad error	<p>A setting cannot be made, because data copying timeout expired.</p> <ol style="list-style-type: none"> 1. Redo data copying. 2. Verify if copying data is authorized. If it is authorized, try again to copy data. 3. Shut down the system, wait for ten minutes, and then power on again the system. <p>If none of the solution above works, contact your local authorized dealer.</p>
	Other AC drive error	<p>This setting cannot be made, due to other keypad issues. (Reserved functions)</p> <p>If such error occurred, contact your local authorized dealer.</p>
	File is locked with password	<p>This setting cannot be made, due to other motor drive issues. (Reserved functions).</p> <p>If such error occurred, contact your local authorized dealer.</p>

※ The content in this chapter only applies on V1.01 and above of KPC-CC01 keypad.

9-6 TPEditor Installation

TPEditor can edit up to 256 HMI (Human-Machine Interface) pages with a total storage capacity of 256kb. Each page can edit 50 normal objects and 10 communication objects.

1) TPEditor: Setup & Basic Functions

1. Run TPEditor version 1.60 or later.



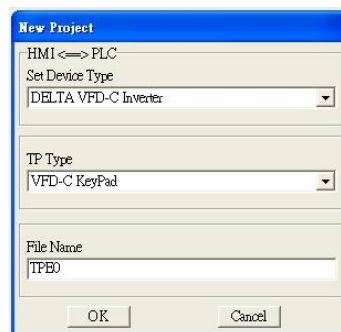

2. Go to File(F)→Click on New. The Window below will pop up. At the device type, click on the drop down menu and choose DELTA VFD-C Inverter. At the TP type, click on the drop down menu and choose VFD-C KeyPad. As for File Name, enter TPE0. Now click on OK.



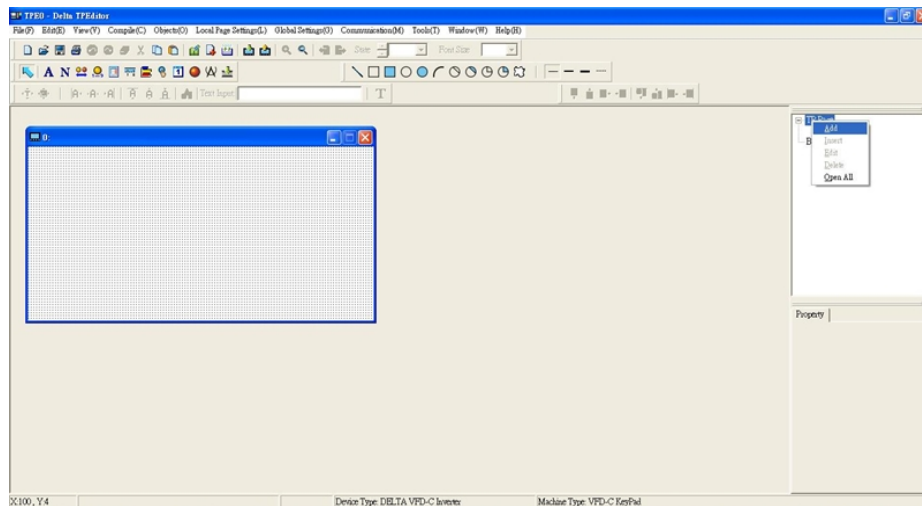

3. You are now at the designing page. Go to Edit (E)→Click on Add a New Page (A) or go to the TP page on the upper right side, right click once on TP page and choose Add to increase one more page for editing. The current firmware of Keypad is version1.00 and can support up to 4 pages.

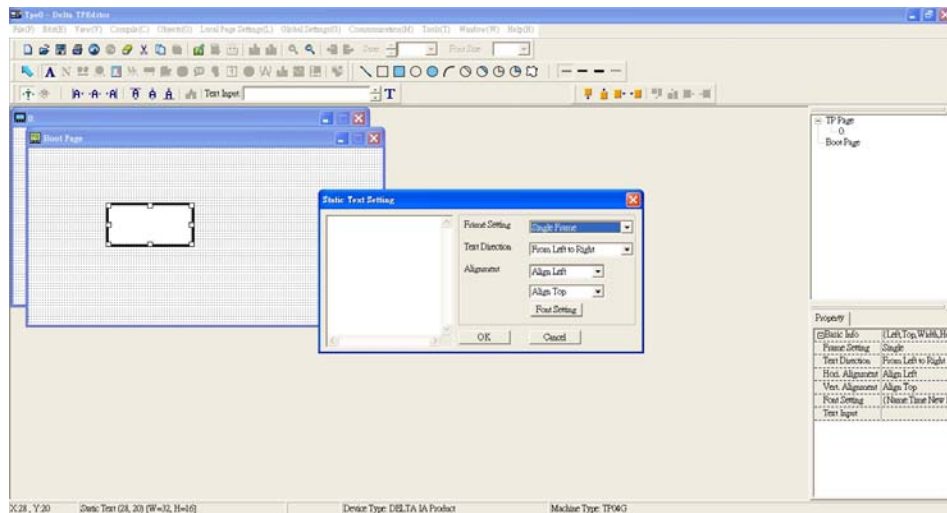

4. Edit Startup Page

5. Static Text  . Open a blank page, click once on this button  , and then double click on that blank page. The following windows will pop up.



6. Static Bitmap  → Open a blank page, then click once on this button  and then double click on that blank page. The following window will pop up.

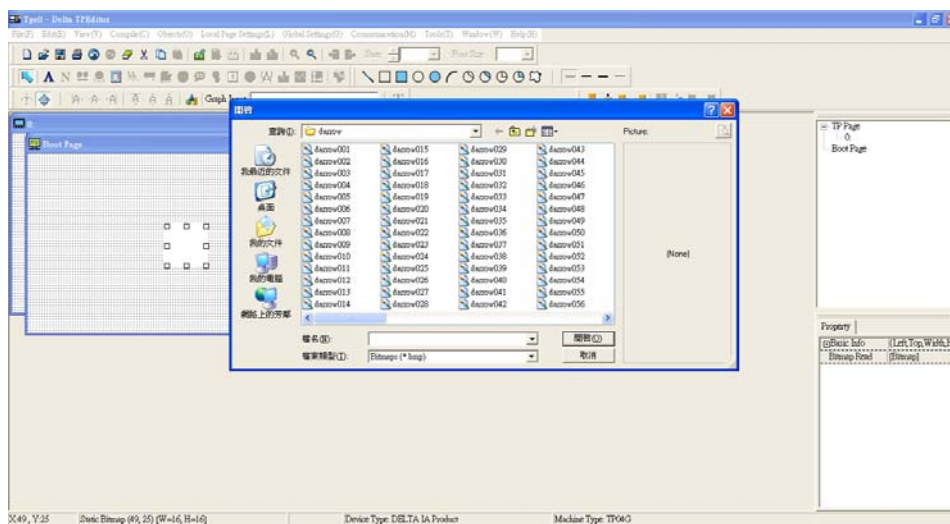

Please note that Static Bitmap setting support only images in BMP format. Now choose a image that you need and click open, then that image will appear in the Static Bitmap window.

7. Geometric Bitmap  → As shown in the picture on the left side, there are 11 kinds of geometric bitmap to choose. Open a new blank page then click once on a geometric bitmap icon that you need. Then drag that icon and enlarge it to the size that you need on that blank page.

8. Finish editing the keypad starting screen and select **Communication>Input User Defined Keypad Starting Screen**.

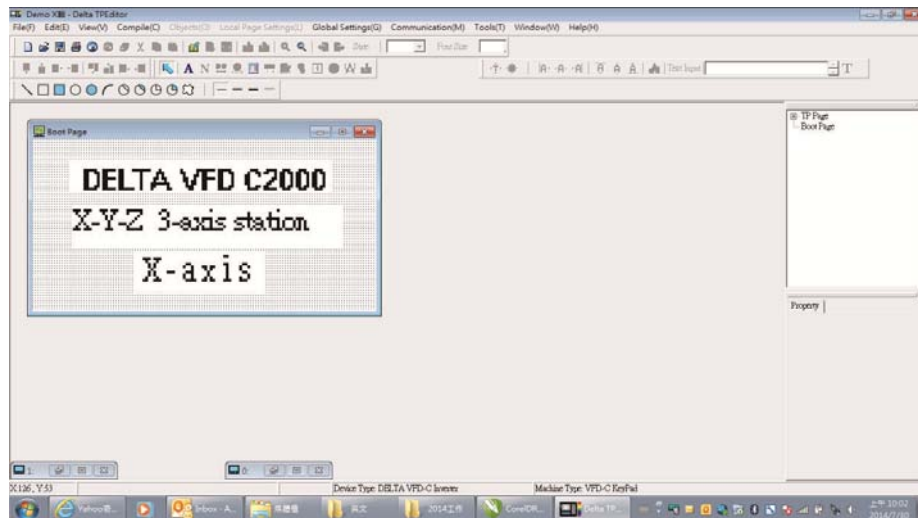

9. Downloading setting: Go to Tool > Communication. Set up communication port and speed of IFD6530.
 10. Only three speed selections are available: 9600 bps, 19200 bps and 38400 bps.

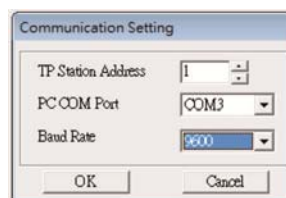

11. When a dialogue box displayed on the screen asking to confirm writing or not, press buttons on the keypad to go to MENU, select PC LINK and then press ENTER and wait for few seconds. Then select YES on the screen to start downloading.

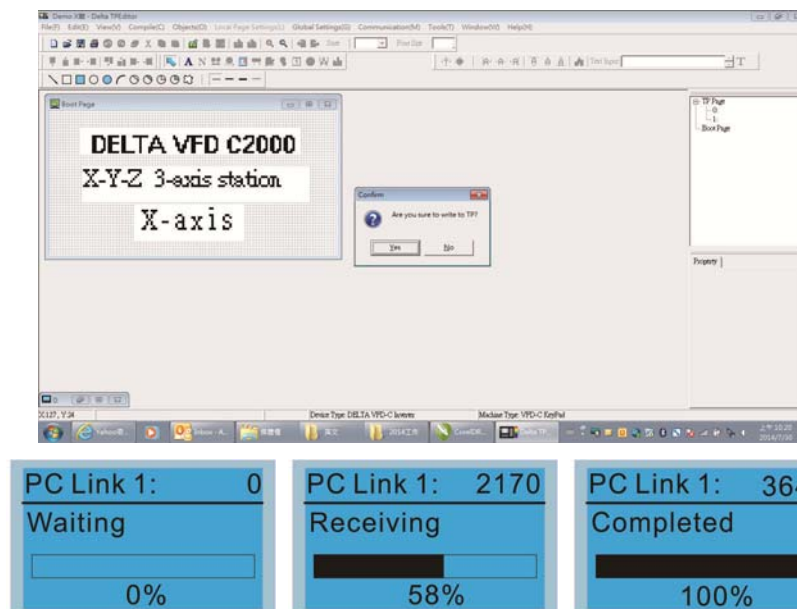

2) Edit Main Page & Example of Download

1. Go to editing page, select Edit→Add one page or press the button ADD on the right hand side of the HMI page to increase number of pages to edit. This keypad currently support up to 256 pages.

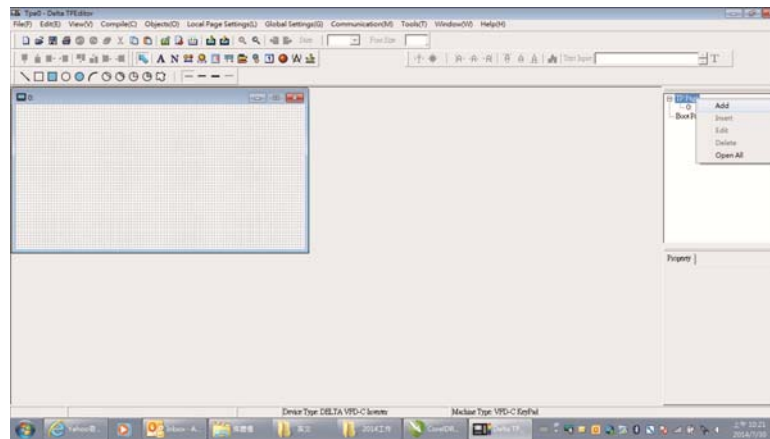

2. On the bottom right-hand corner of the HMI, click on a page number to edit or go to VIEW >HMI page to start editing main page. As shown in the image, the following objects are available. From left to right: Static Text, ASCII Display, Static Bitmap, Scale, Bar Graph, Button, Clock Display, Multi-state bit map, Units, Numeric Input and 11 geometric bitmaps and lines of different width. The application of Static Text, Static Bitmap, and geometric bitmap is the same as the editing startup page.



3. Numeric/ASCII Display : To add a Numeric/ASCII Display object to a screen, double click on the object to set up Related Devices, Frame Setting , Fonts and Alignment.

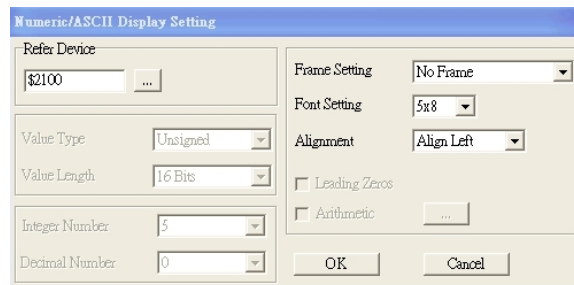

Related Device: Choose the VFD Communication Port that you need, if you want to read output frequency (H), set the VFD Communication Port to \$2202. For other values, please refer to ACMD ModBus Comm Address List.



4. Scale Setting  : On the Tool Bar, click on this  for Scale Setting. You can also edit Scale Setting in the Property Window on the right hand side of your computer screen.

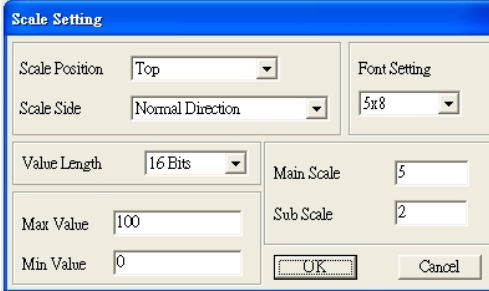

The Scale Setting dialog box contains the following fields and controls:

- Scale Position: Top (dropdown)
- Scale Side: Normal Direction (dropdown)
- Font Setting: 5x8 (dropdown)
- Value Length: 16 Bits (dropdown)
- Main Scale: 5 (text input)
- Sub Scale: 2 (text input)
- Max Value: 100 (text input)
- Min Value: 0 (text input)
- Buttons: OK, Cancel

- Scale Position: Click on the drop down list to choose which position that you need to place a scale.
- Scale Side: Click on the drop down list to choose if you want to number your scale from smaller number to bigger number or from big to small. Click OK to accept this setting or click Cancel to abort.
- Font Setting: Click on the drop down list to choose the Font setting that you need then click OK to accept the setting or click Cancel to abort.
- Value Length: Click on the drop down to choose 16bits or 32 bits. Then click OK to accept the setting or click Cancel to abort.
- Main Scale & Sub Scale: In order to divide the whole scale into equal parts, key in the numbers of your choices for main scale and sub scale.
- Maximum value & Minimum Value are the numbers on the two ends of a scale. They can be negative numbers. But the values allowed to be input are limited by the length of value. For example, when the length of value is set to **be hexadecimal**, the maximum and the minimum value cannot be input as -4000.
Follow the Scale setting mentioned above; you will have a scale as shown below.

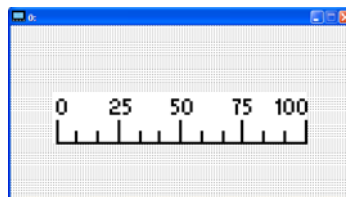

5. Bar Graph setting  :

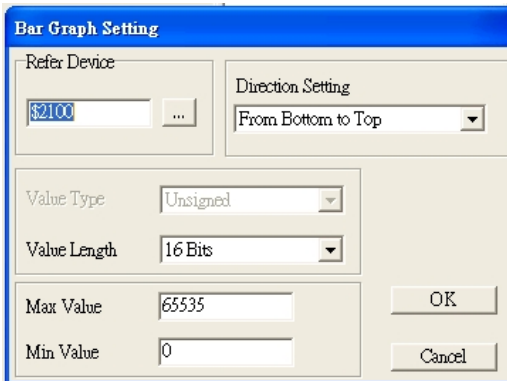

The Bar Graph Setting dialog box contains the following fields and controls:

- Refer Device: \$2100 (text input)
- Direction Setting: From Bottom to Top (dropdown)
- Value Type: Unsigned (dropdown)
- Value Length: 16 Bits (dropdown)
- Max Value: 65535 (text input)
- Min Value: 0 (text input)
- Buttons: OK, Cancel

- Related Device: Choose the VFD Communication Port that you need.
- Direction Setting: Click on the drop down menu to choose one of the following directions: From Bottom to Top, From Top to Bottom, From Left to Right or From Right to Left.
- Maximum Value & Minimum Value: They define the range covered by the maximum value and minimum value. If a value is smaller than or equal to the minimum value, then the bar graph will be blank. If a value is bigger or equal to the maximum value, then the bar graph will be full. If a value is between minimum and maximum value, then the bar graph will be filled proportionally.

6. Button  : Currently this function only allows the Keypad to switch pages, other functions are not yet available. Text input function and Image inserted functions are not yet supported.

Double click on  to open set up window.

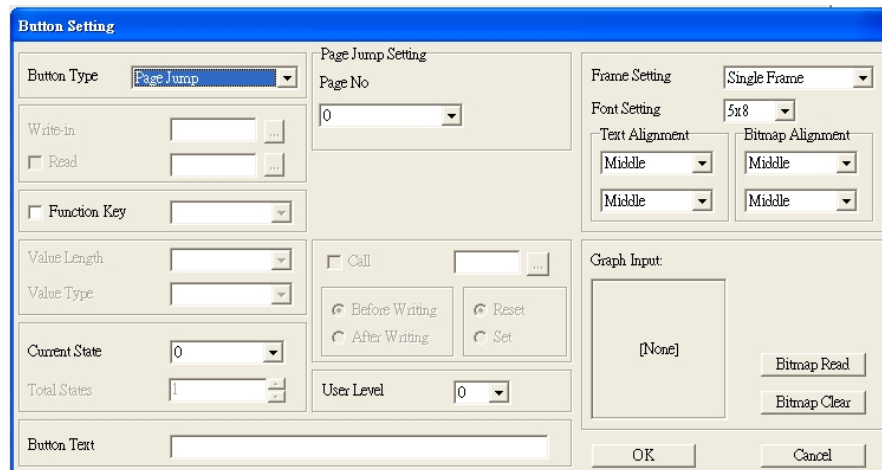

<Button Type> allows users set up buttons' functions. <Page Jump> and <Constant Setting> are the only two currently supported functions.

A [Page Jump] function setting

- Page Jump setting: After you choose the Page Jump function in the drop down list, you will see this Page Jump Setting Menu
- <Function Key> allows you to assign functions to the following keys on the KPC-CC01 keypad: F1, F2, F3, F4, Up, Down, Left and Right. Please note that the Up and Down keys are locked by TPEditor. These two keys cannot be programmed. If you want to program Up and Down keys, go to Tool→Function Key Settings (F)→Re-Define Up/Down Key(R).

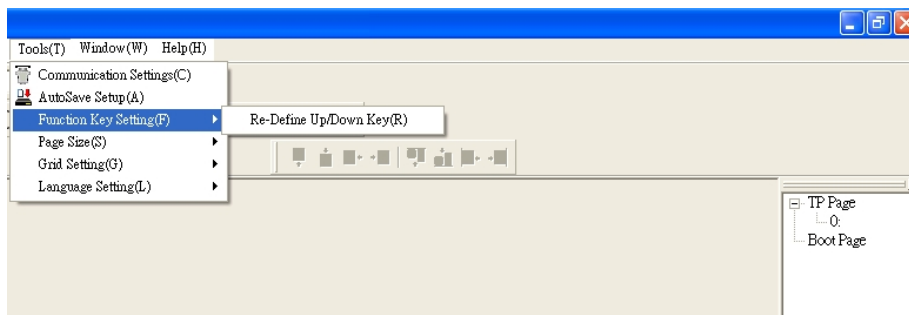

- Button Text: This function allows user to name buttons. For example, key in <Next Page> in the empty space, a button will have the wording <Next Page> displayed on it.

B [Constant setting] function

This function is to set up the memory address' value of the VFD or PLC. When pressing the <function button> set up in before, a value will be written to the memory address of the <Constant Setting>. This function can be used as initializing a variable.



7. Clock Display Setting  : The setup window of the Clock Display is shown as the image below. Time, Day or Date can be displayed on the keypad.
Open a new file and click once in that window, you will see the following
In the clock display setting, you can choose to display Time, Day or Date on the Keypad. To adjust time, go to #9 on the Keypad's menu. You can also adjust Frame Setting, Font Setting and Alignment.

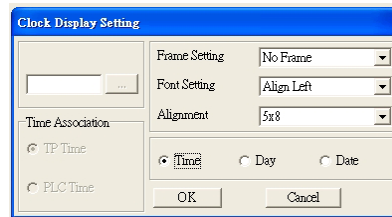

8. Multi-state bitmap  : The setup window of the multi-state is shown as the image below. This object reads the bit's property value of the PLC. It defines what image or wording is when this bit is 0 or when this bit is 1. Set the initial status to be 0 or 1 to define the displayed image or wording.

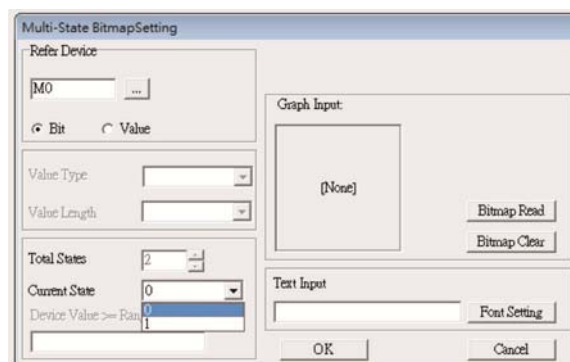

9. Unit Measurement  : Click once on this Button:
Open a new file and double click on that window, you will see the following

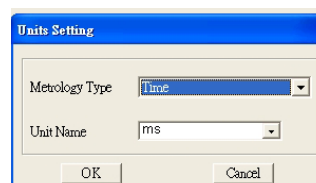

Choose from the drop down list the Metrology and the Unity Name that you need.
As for Metrology, you have the following choices Length, Square Measure, Volume/Solid Measure, Weight, Speed, Time and Temperature. The unit name changes automatically when you change metrology type.

10. Numeric Input Setting

This menu allows you to provide parameters or communication ports and to input numbers.

Click once on this button .

Open a new file and double click on that window, you will see the following:

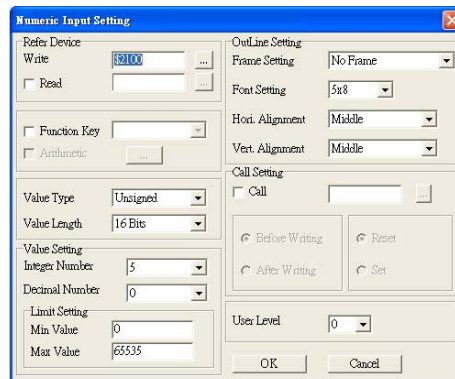

- Related Device: There are two blank spaces to fill in, one is <Write> and another one is <Read>. Input the numbers that you want to display and the corresponding numbers of a parameter and that of a communication port. For example, input 012C to Read and Write Parameter P01-44.
- OutLine Setting: The Frame setting, Font setting, Vertical Alignment and Horizontal Alignment are the same as mentioned before. Click on the drop down menu and choose the setting that you need.
- Function key: The setting here allows you to program keys on the keypad. Press the key on the menu then the corresponding key on the keypad will start to blink, then press Enter to confirm the setting.
- Value Type & Value Length: These two factors influence the range of the Minimum and Maximum Value of the Limit Setting. Please note that the corresponding supporting values for C2000 have to be 16bits. The 32bits values are not supported.
- Value Setting: This part is set automatically by the keypad itself.
- Limit Setting: Input the range the security setting here.
- For example, if you set Function Key as F1, Minimum Value as 0 and Maximum Value as 4, then press F1 on Keypad Then you can press Up and Down key on the keypad to increase or decrease the value. Press Enter Key on the keypad to confirm your setting. You can also go to parameter table 01-44 to verify if your input correctly the value.

11. Download TP Page : Press Up or Down key on the keypad until you reach #13 PC Link.

Then press Enter on the keypad and you will see the word "Waiting" on keypad's screen. Now choose a page that you have created then go to Communication (M)→Write to TP(W) to start downloading the page to the keypad

When you see the word Completed on the keypad's screen, that means the download is done. Then you can press ESC on the keypad to go back to the menu of the keypad.

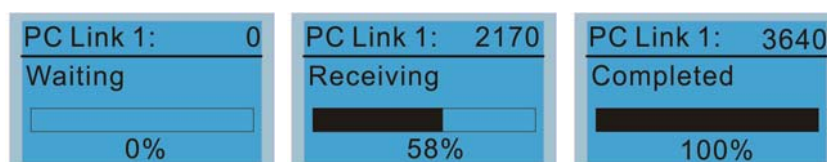
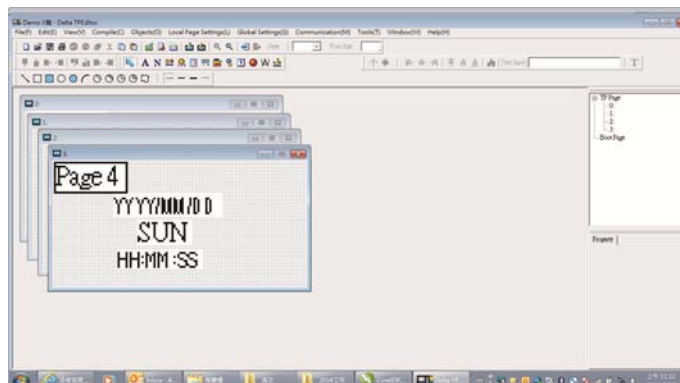

3) Edit Main Page

1. On the bottom right-hand corner of the HMI, click on a page number to edit or go to VIEW >HMI page to start editing main page. As shown in the image, the following objects are available. From left to right: Static Text, ASCII Display, Static Bitmap, Scale, Bar Graph, Button, Clock Display, Multi-state bit map, Units, Numeric Input and 11 geometric bitmaps and lines of different width. The application of Static Text, Static Bitmap, and geometric bitmap is the same as the editing startup page.

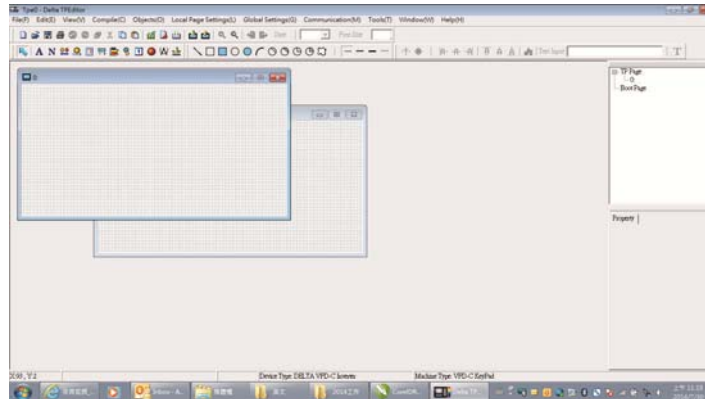

2. Numeric/ASCII Display : To add a Numeric/ASCII Display object to a screen, double click on the object to set up Related Devices, Frame Setting , Fonts and Alignment.

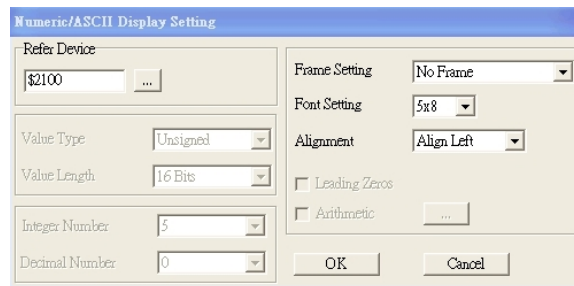

Related Device: Choose the VFD Communication Port that you need, if you want to read output frequency (H), set the VFD Communication Port to \$2202. For other values, please refer to ACMD ModBus Comm Address List.



3. Scale Setting  : On the Tool Bar, click on this  for Scale Setting. You can also edit Scale Setting in the Property Window on the right hand side of your computer screen.

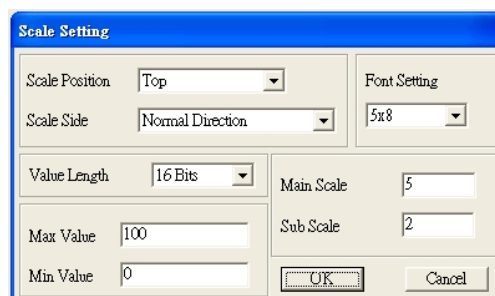

- i. Scale Position: Click on the drop down list to choose which position that you need to place a scale.
- ii. Scale Side: Click on the drop down list to choose if you want to number your scale from smaller number to bigger number or from big to small. Click OK to accept this setting or click Cancel to abort.
- iii. Font Setting: Click on the drop down list to choose the Font setting that you need then click OK to accept the setting or click Cancel to abort.
- iv. Value Length: Click on the drop down to choose 16bits or 32 bits. Then click OK to accept the setting or click Cancel to abort.
- v. Main Scale & Sub Scale: In order to divide the whole scale into equal parts, key in the numbers of your choices for main scale and sub scale.
- vi. Maximum value & Minimum Value are the numbers on the two ends of a scale. They can be negative numbers. But the values allowed to be input are limited by the length of value. For example, when the length of value is set to **be hexadecimal**, the maximum and the minimum value cannot be input as -4000.

Follow the Scale setting mentioned above; you will have a scale as shown below.

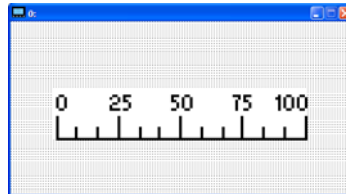

4. Bar Graph setting :

- i. Related Device: Choose the VFD Communication Port that you need.
- ii. Direction Setting: Click on the drop down menu to choose one of the following directions: From Bottom to Top, From Top to Bottom, From Left to Right or From Right to Left.
- iii. Maximum Value & Minimum Value: They define the range covered by the maximum value and minimum value. If a value is smaller than or equal to the minimum value, then the bar graph will be blank. If a value is bigger or equal to the maximum value, then the bar graph will be full. If a value is between minimum and maximum value, then the bar graph will be filled proportionally.

5. Button : Currently this function only allows the Keypad to switch pages, other functions are not yet available. Text input function and Image inserted functions are not yet supported.

Double click on  to open set up window.

<Button Type> allows users set up buttons' functions. <Page Jump> and <Constant Setting> are the only two currently supported functions.

A [Page Jump] function setting

- Page Jump setting: After you choose the Page Jump function in the drop down list, you will see this Page Jump Setting Menu
- <Function Key> allows you to assign functions to the following keys on the KPC-CC01 keypad: F1, F2, F3, F4, Up, Down, Left and Right. Please note that the Up and Down keys are locked by TPEditor. These two keys cannot be programmed. If you want to program Up and Down keys, go to Tool→Function Key Settings (F)→Re-Define Up/Down Key(R).

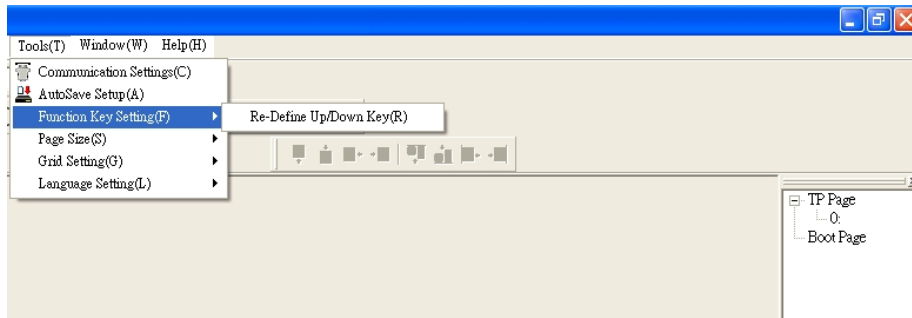

- Button Text: This function allows user to name buttons. For example, key in <Next Page> in the empty space, a button will have the wording <Next Page> displayed on it.

B [Constant setting] function

This function is to set up the memory address' value of the VFD or PLC. When pressing the <function button> set up in before, a value will be written to the memory address of the <Constant Setting>. This function can be used as initializing a variable.



11. Clock Display Setting 1: The setup window of the Clock Display is shown as the image below. Time, Day or Date can be displayed on the keypad.

Open a new file and click once in that window, you will see the following

In the clock display setting, you can choose to display Time, Day or Date on the Keypad. To adjust time, go to #9 on the Keypad's menu. You can also adjust Frame Setting, Font Setting and Alignment.

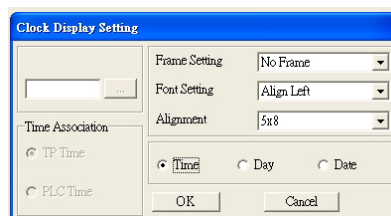

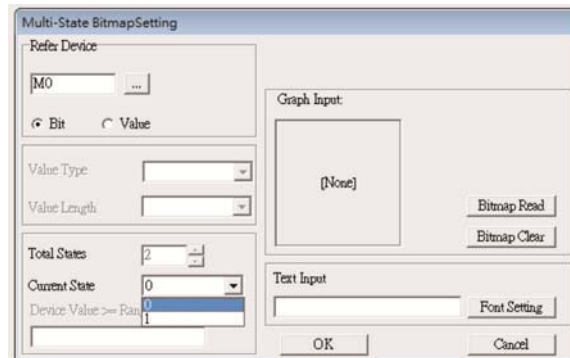

12. Multi-state bitmap : The setup window of the multi-state is shown as the image below. This object reads the bit's property value of the PLC. It defines what image or wording is when this bit is 0 or when this bit is 1. Set the initial status to be 0 or 1 to define the displayed image or wording.

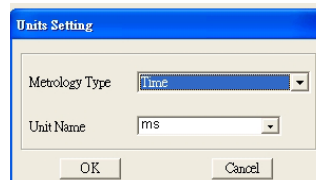

13. Unit Measurement : Click once on this Button:
Open a new file and double click on that window, you will see the following



Choose from the drop down list the Metrology and the Unity Name that you need. As for Metrology, you have the following choices Length, Square Measure, Volume/Solid Measure, Weight, Speed, Time and Temperature. The unit name changes automatically when you change metrology type.

14. Numeric Input Setting :
This menu allows you to provide parameters or communication ports and to input numbers.
Click once on this button .
Open a new file and double click on that window, you will see the following:

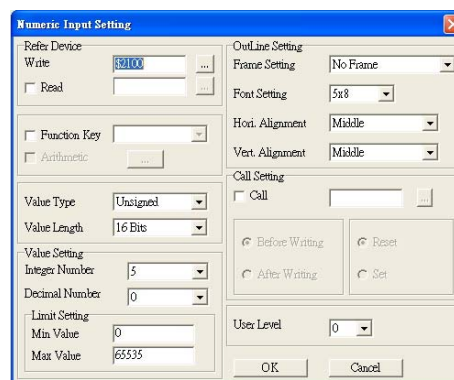

- h. Related Device: There are two blank spaces to fill in, one is <Write> and another one is <Read>. Input the numbers that you want to display and the corresponding numbers of a parameter and that of a communication port. For example, input 012C to Read and Write Parameter P01-44.
- i. OutLine Setting: The Frame setting, Font setting, Vertical Alignment and Horizontal Alignment are the same as mentioned before. Click on the drop down menu and choose the setting that you need.
- j. Function key: The setting here allows you to program keys on the keypad. Press the key on the menu then the corresponding key on the keypad will start to blink, then press Enter to confirm the setting.
- k. Value Type & Value Length: These two factors influence the range of the Minimum and Maximum Value of the Limit Setting. Please note that the corresponding supporting values for C2000 have to be 16bits. The 32bits values are not supported.
- l. Value Setting: This part is set automatically by the keypad itself.

- m. Limit Setting: Input the range the security setting here.
- n. For example, if you set Function Key as F1, Minimum Value as 0 and Maximum Value as 4, then press F1 on Keypad Then you can press Up and Down key on the keypad to increase or decrease the value. Press Enter Key on the keypad to confirm your setting. You can also go to parameter table 01-44 to verify if your input correctly the value.

15. Download TP Page : Press Up or Down key on the keypad until you reach #13 PC Link.

Then press Enter on the keypad and you will see the word "Waiting" on keypad's screen. Now choose a page that you have created then go to Communication (M)→Write to TP(W) to start downloading the page to the keypad

When you see the word Completed on the keypad's screen, that means the download is done. Then you can press ESC on the keypad to go back to the menu of the keypad.

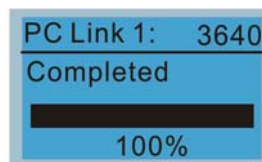
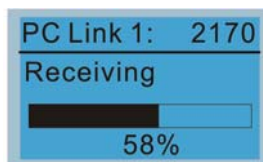
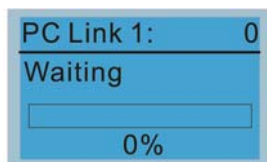
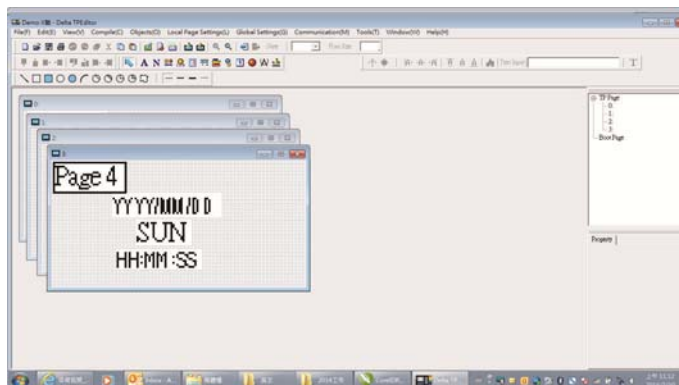

10 Auto-tuning Process

■ Flow Chart

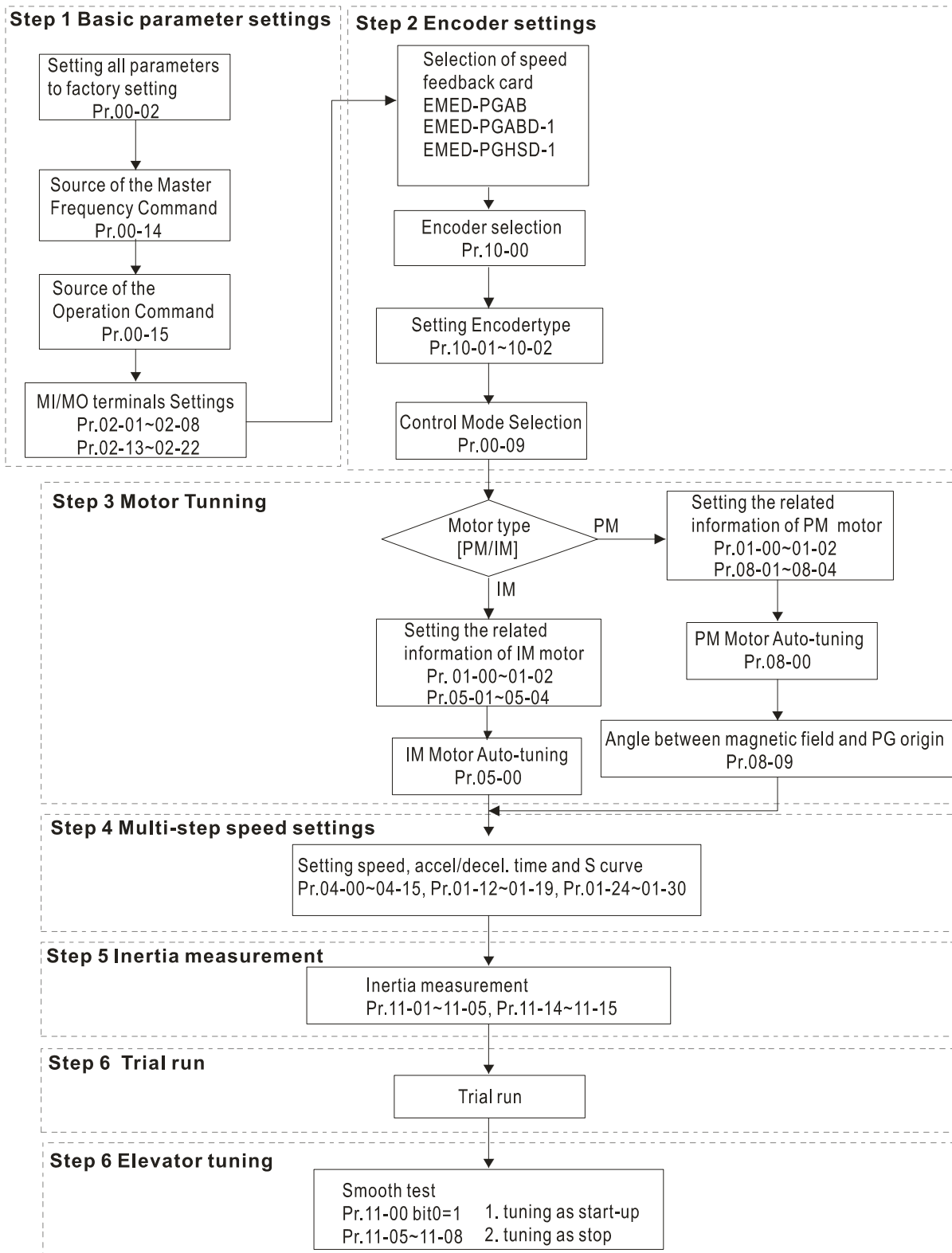

■ Explanations for the Auto-tuning Steps

Step1

Basic Parameters Settings

- Make sure that Pr.00-00 (identity code of the AC motor drive) corresponds with the nameplate indicated on the AC motor drive.
-
- Make sure that all parameters are reset to factory setting (Pr.00-02 is set to 9 or 10).

Pr00-02	0: No function
Parameter	1: Read only
Reset	8: Keypad lock
	9: All parameters are reset to factory settings (base frequency = 50Hz)
	10: All parameters are reset to factory settings (base frequency = 60Hz)

■

- Source of the Master Frequency Command: It is user-defined. (Pr.00-14)

■

Pr00-14	1: RS-485 serial communication or digital keypad (KPC-CC01)
Source of	2: External analog input (Pr. 03-00)
the Master	3: Digital terminals input (Pr04-00 ~ Pr.04-15)
Frequency	
Command	

■

- Source of the Operation Command: It is user-defined. (Pr.00-15)

■

Pr00-15	1: External terminals
Source of	2: RS-485 serial communication or digital keypad (KPC-CC01)
the operation	
frequency	

- MI/MO External Terminal Settings:

Refer to Pr.02-01~Pr02-08 for setting of the external input terminals MI1~MI8.

NOTE: The factory setting of Pr.02-08 is 40 (Enable drive function).

Disable this function, if you don't need to use it.

Settings of	0: No function
Pr02-01 to	1: multi-step speed command 1
Prp02-08	2: multi-step speed command 2
	3: multi-step speed command 3
	4: multi-step speed command 4
	5: Reset
	6: JOG command
	7: Acceleration/ Deceleration Speed inhibit
	8: the 1st, 2nd acceleration/deceleration time selection
	9: the 3rd, 4th acceleration/deceleration time selection
	10: EF input (07-28)
	11: Reserved
	12: Stop Output
	13: Reserved
	14: Reserved
	15: Operation speed command form AUI1
	16: Reserved
	17: operation speed command form AUI2
	18: Emergency stop (Pr07-28)
	19~23: Reserved
	24: FWD JOG command

25: REV JOG command
 26: Reserved
 27: ASR1/ASR2 selection
 28: Emergency stop (EF1) (Motor coasts to stop)
 29-30: Reserved
 31: High torque bias (by Pr.07-21)
 32: Middle torque bias (by Pr.07-22)
 33: Low torque bias (by Pr.07-23)
 34-37: Reserved
 38: Disable write EEPROM function
 39: Torque command direction
 40: Enable drive function
 41: Detection for magnetic contactor
 42: Mechanical brake
 43: EPS function

Refer to Pr02-15 and Pr02-16 for the settings of MO1~MO8

Pr02-15~ 0: No function
 Pr02-16 1: Operation indication
 2: Operation speed attained
 3: Desired frequency attained 1 (Pr.02-25)
 4: Desired frequency attained 2 (Pr.02-27)
 5: Zero speed (frequency command)
 6: Zero speed with stop (frequency command)
 7: Over torque (OT1) (Pr.06-05~06-07)
 8: Over torque (OT2) (Pr.06-08~06-10)
 9: Drive ready
 10: User-defined Low-voltage Detection (LV)
 11: Malfunction indication
 12: Mechanical brake release (Pr.02-29, Pr.02-30)
 13: Overheat (Pr.06-14)
 14: Brake chopper signal
 15: Motor-controlled magnetic contactor output
 16: Slip error (oSL)
 17: Malfunction indication
 18: Reserved
 19: Brake chopper output error
 20: Warning output
 21: Over voltage warning
 22: Over-current stall prevention warning
 23: Over-voltage stall prevention warning
 24: Operation mode indication (Pr.00-15≠0)
 25: Forward command
 26: Reverse command
 27: Output when current \geq Pr.02-33
 28: Output when current $<$ Pr.02-33
 29: Output when frequency \geq Pr.02-34
 30: Output when frequency $<$ Pr.02-34
 31-32: Reserved
 33: Zero speed (actual output frequency)
 34: Zero speed with Stop (actual output frequency)
 35: Error output selection 1 (Pr.06-22)
 36: Error output selection 2 (Pr.06-23)
 37: Error output selection 3 (Pr.06-24)
 38: Error output selection 4 (Pr.06-25)
 39: Reserved
 40: Speed attained (including zero speed)
 41: Reserved
 42: SO logic A output

Step2

Encoder Settings

- Selection of speed feedback cards
 - Refer to CH07 Speed Feedback Card Selection. Delta provides 2 kinds of PG card for user to choose, including EMED-PGABD-1 and EMED-PGHSD-1.

Pr10-00	0: No function
Type of PG signal	1: ABZ
	2: ABZ+Hall
	3: SIN/COS + Sinusoidal
	4: SIN/COS + Endat
	5: SIN/COS
	6: SIN/COS + Hiperface

- Encoder settings: Pr.10-01~Pr.10-02

Detection for the magnetic pole position of motor

The detection method will be different by the setting of Pr.10-00 PG Signal Type.

The detection methods: (refer to Pr.10-00)

- Setting 1 or 5: The AC motor drive will output short circuit to detect the position of the magnetic pole. At this moment, the motor will generate a little noise.
- Setting 2: The AC motor drive will detect the position of the magnetic pole by the UVW signal of PG.
- Setting 3: The AC motor drive will detect the position of the magnetic pole by the sine signal of PG.
- Setting 4: The AC motor drive will detect the position of the magnetic pole by the communication signal of PG.

Pr10-01	1~25000
Encoder Pulse	

Type of Encoder Input Setting. The setting of this parameter is normally 1, if the motor doesn't run at setting 1, change to setting 2.

Pr10-02	0: No function
Type of Encoder Input Setting	1: Phase A leads in a forward run command and phase B leads in a reverse run command
	2: Phase B leads in a forward run command and phase A leads in a reverse run command
	3: Phase A is a pulse input and phase B is a direction input. (low input=reverse direction, high input=forward direction)
	4: Phase A is a pulse input and phase B is a direction input. (low input=forward direction, high input=reverse direction)
	5: Single-phase input

Step 3

Motor tuning

- Setting the parameters according to the motor type (PM or IM)
- Motor Auto-tuning: When the Source of the Operation Command is set to digital keypad (Pr.00-15=2, refer to step 1)
- Control method: Please set Pr.00-09 to 8.

Pr00-09 Control Method	0: V/f Control
	1: V/f Control + Encoder (VFPG)
	2: Sensorless vector control (SVC)
	3: FOC vector control + Encoder (FOCPG)
	4: Torque control + Encoder (TQCPG)
	8: FOC PM control (FOCPM)

- NOTE: Setting parameter by the motor type (PM or IM).
- Inputting the nameplate information on the motor into Pr.01-00~01-02

Pr01-00 Maximum Output Frequency	10.00~400.00Hz
-------------------------------------	----------------

Pr01-01 1st Output Frequency Setting 1 (base frequency/ motor rated frequency)	0.00~400.00Hz
--	---------------

Pr.01-02 1st Output Voltage Setting 1 (base voltage/ motor rated voltage)	230V models: 0.0V~255.0V 460V models: 0.0V~510.0V
---	--

【IM (Induction Motor)】

- Motor Auto-tuning: When the Source of the Operation Command is set to digital keypad (Pr.00-15=2, refer to step 1) and setting Pr.05-00=2
-

Pr05-00 Motor Auto Tuning	0: No function
	1: Rolling test (Rs, Rr, Lm, Lx, no-load current) , (Motor runs)
	2: Static Test (Motor doesn't run)

NOTE 1: It doesn't need to release the brake in this auto tuning operation. Please make sure that the electromagnetic valve is ON when it is used between the AC motor drive and motor. When Pr.05-00 is set to 2, no-load current of motor must be entered into Pr.05-05. The warning message "Auto tuning" will be displayed on the digital keypad during tuning until it is finished. Then, the measure result will be saved into Pr.05-06~Pr.05-09.

NOTE 2: It needs to finish motor auto tuning before measuring the angle between magnetic pole and PG origin.

Pr05-01 Full-load Current of Motor	(40~120%) *00-01 Amps
---------------------------------------	-------------------------

Pr05-02 Rated Power of Motor	0.00~655.35kW
---------------------------------	---------------

Pr05-03 Rated Speed of Motor(rpm)	0~65535
--------------------------------------	---------

Pr05-04 Number of Motor Poles	2~9
-------------------------------------	-----

【Permanent Magnet Motor】

- Motor Auto-tuning: When the Source of the Operation Command is set to digital keypad (Pr.00-15=2, refer to step 1) and setting Pr.08-00=2

Pr08-00 Motor Auto Tuning	0: No function 1: Only for the unloaded motor, auto measure the Angle between magnetic pole and PG origin (08-09) 2: For PM parameters 3: Auto measure the Angle between magnetic pole and PG origin (08-09)
------------------------------	---

NOTE 1: It doesn't need to release the brake in this auto tuning operation. Please make sure that the electromagnetic valve is ON when it is used between the AC motor drive and motor. The warning message "Auto tuning" will be displayed on the digital keypad during tuning until it is finished. Then, the measure result will be saved into Pr.08-05 and Pr.08-07. (Pr.08-05 is Rs of Motor and Pr.08-07 is Lq of Motor)

NOTE 2: It is recommended to set Pr.08-00 to 1 (unloaded motor) for the most accurate calculation. If it needs to execute this function with loaded motor, please balance the carriage before execution.

When Pr.08-00=1, please note:

- When executing the function of auto measure the Angle between magnetic pole and PG origin, it is recommended to stop the carriage car at the middle level.
- Make sure that the electromagnetic valve and mechanical brake are OFF before executing this function.
- When Pr.08-00=1, please execute this function with unloaded motor to get the most accurate result. If it needs to execute this function with loaded motor, please balance the carriage before execution. Make sure the balance by releasing the brake manually before running. This balance will affect the accuracy and the accuracy will influence the power efficiency in driving the motor.

■
NOTE 3: If it doesn't allow balancing carriage in the measured environment, it can set Pr.08-00 to 3 for executing this function. It will have a difference of 15~30° by the different encoder type.

- When Pr.08-00 is set to 3, the driver will execute the function by the setting of Pr.10-00. The difference between Pr.08-00=3 and Pr.08-00=1 is it doesn't need to put the balanced carriage when Pr.08-00=3. Besides, the operation status of the motor will be as shown in the above table (Pr.10-00=1, 2, 3 and 5, the motor will run. Pr.10-00=4 and 6, the motor won't run)
- When Pr.08-00=3, please make sure if the setting of Pr.10-02 is correct. The incorrect setting will result in the wrong position of the magnetic pole and make the wrong angle between magnetic pole and PG origin.

■
NOTE 4: The warning message "Auto tuning" will be displayed on the digital keypad during tuning until it is finished. Then, the measure result will be saved into Pr.08-09.

NOTE 5: If the warning message "Auto Tuning Err" displayed on the digital keypad during tuning due to abnormal drive or human factor, please check if the wiring is correct. When the warning message "PG Fbk Error" displayed on the digital keypad, please change the setting of Pr.10-02 (for example: if it was set to 1, please change it to 2). When the warning message "PG Fbk Loss" is displayed on the digital keypad, please check the feedback of Z-phase pulse.

Pr.08-01 Full-load Current of Motor	(40~120%)*00-01 Amps
Pr.08-02 Rated power of Motor	0.00~655.35 kW
Pr.08-03 Rated speed of Motor (rpm)	0~65535
Pr.08-04 Number of Motor Poles	2~96

■ Measure the angle between magnetic pole and PG origin

It can execute "RUN" by keypad or digital terminals:

1. Using digital keypad: setting Pr.08-00 to 1 and press "RUN" to execute "auto measure the angle between magnetic pole and PG origin". Please note that if the electromagnetic valve and brake are not controlled by the AC motor drive, please release it by manual.
2. Using external terminals: setting Pr.00-14=3 (frequency source) and Pr.00-15=1 (operation source). Please use "inspection" function to execute "auto measure the angle between magnetic pole and PG origin".

For the IM, it doesn't need to detect the position of the magnetic pole, this function (auto measure the Angle between magnetic pole and PG origin) doesn't have to be executed.

Measure the angle between magnetic pole and PG origin: Pr.08-00=1 or 3

Pr.08-00 Motor Auto tuning	<p>0: No function</p> <p>1: Only for the unloaded motor, auto measure the Angle between magnetic pole and PG origin (08-09)</p> <p>2: For PM parameters</p> <p>3: Auto measure the Angle between magnetic pole and PG origin (08-09)</p>
-------------------------------	--

NOTE: The function of "auto measure the angle between magnetic pole and Pg origin" only can be enabled after finishing motor auto-tuning.

Step 4**Multi-Step Speed setting or Analog setting****(Do not wire the two settings at the same time)****A. Multi-step speed settings**

- Confirm the total speed steps (high speed, middle speed, low speed, creep, inspection and level auto-learning)
- Make sure that the setting of step speeds and the action of the corresponding terminals of multi-function input commands are correct.
- Setting multi-step speeds in Pr.04-00 to Pr.04-15

■

Settings of Pr.04-00 to Pr.04-15	Zero Step Speed Frequency	0.00~400.00Hz
	1st Step Speed Frequency	0.00~400.00Hz
	2nd Step Speed Frequency	0.00~400.00Hz
	3rd Step Speed Frequency	0.00~400.00Hz
	4th Step Speed Frequency	0.00~400.00Hz
	5th Step Speed Frequency	0.00~400.00Hz
	6th Step Speed Frequency	0.00~400.00Hz
	7th Step Speed Frequency	0.00~400.00Hz
	8th Step Speed Frequency	0.00~400.00Hz
	9th Step Speed Frequency	0.00~400.00Hz
	10th Step Speed Frequency	0.00~400.00Hz
	11th Step Speed Frequency	0.00~400.00Hz
	12th Step Speed Frequency	0.00~400.00Hz
	13th Step Speed Frequency	0.00~400.00Hz
	14th Step Speed Frequency	0.00~400.00Hz
15th Step Speed Frequency	0.00~400.00Hz	

■

NOTE: It is recommended to set the max. operating frequency to the half of max. operating frequency before confirming the setting of each step speed and the action of the corresponding terminals of multi-function input commands.

- Setting the acceleration/deceleration with Pr.01-23 and the setting 08 (the 1st, 2nd acceleration/deceleration time selection) and 09 (the 3rd, 4th acceleration/deceleration time selection) of multi-function input command Pr.02-01~02-08.
- Settings of acceleration/deceleration time: Pr.01-12~Pr.01-19

Settings of Pr.01-12 to Pr.01-19	Accel Time 1	0.00~600.00 sec
	Decel Time 1	0.00~600.00 sec
	Accel Time 2	0.00~600.00 sec
	Decel Time 2	0.00~600.00 sec
	Accel Time 3	0.00~600.00 sec
	Decel Time 3	0.00~600.00 sec
	Accel Time 4	0.00~600.00 sec
	Decel Time 4	0.00~600.00 sec



NOTE: it is recommended to set the Pr.01-31 (deceleration time) to the small value in the trial run and execute smooth test after all the actions are correct.

■ Settings of S curve: Pr.01-24~Pr.01-30

Settings of Pr.01-24 to Pr.01-30	S-curve for Acceleration Departure Time S1	0.00~25.00 sec
	S-curve for Acceleration Arrival Time S2	0.00~25.00 sec
	S-curve for Deceleration Departure Time S3	0.00~25.00 sec
	S-curve for Deceleration Arrival Time S4	0.00~25.00 sec
	Mode Selection when Frequency < Fmin	0: Output waiting 1: Zero-speed operation 2: Fmin (4th output frequency setting)
	Switch Frequency for S3/S4 Changes to S5	0.00~400.00Hz
	S-curve for Deceleration Arrival Time S5	0.00~25.00 sec

NOTE: it is recommended to set the S curve time to 0 in trial run and execute smooth test after all the actions are correct.

B. Analog setting

1. Set Pr00-14=2, frequency command is assigned by the external analog signal.
2. Set Pr00-15 =1, operating command is assigned by the external terminals.
3. In order to work with the control terminal, set up Pr03-23 or Pr03-24 in accordance with the output mode of the controller
4. Set up Pr03-03, PR03-05 or Pr03-06 to work with the connecting port. Set F to display 0Hz when the motor drive is going to stop.

Step5**Inertia**

Pr.11-05 Inertial Ratio	1~300%
----------------------------	--------

Step 6**Trial run**

This step is used to trial run after finishing the settings of Step 1 to Step 5 to check if it runs normally after executing the inspection with the loaded motor. At the same time, please also check if the operations of multi-function output terminals is normal, such as the action of the brake release and electromagnetic valve correspond to the host controller.

It needs to check the switch between each step speed, current value, the noise in the carriage and noise source during operation.

Step 7

Elevator tuning

1. Setting Pr. 11-00 to bit 0=1

Pr.11-00 System control	Bit 0=0: disable Bit 0=1: ASR Auto tuning, PDFF enable Bit 7=1: When position control is enabled, it doesn't need to set Pr.07-02 (DC Brake Current Level) Bit 15=0: when power is applied, it will detect the position of magnetic pole again Bit 15=1: when power is applied, it will start from the magnetic pole position of previous power failure
----------------------------	---

NOTE: bit 15=0, it will detect the position of magnetic pole when the power is applied. (it will detect every time when the power is applied.)

Bit 15=1: when power is applied, it will start from the magnetic pole position of previous power failure. Please make sure that the motor is not manually rotated during power off. If the motor has been rotated during power off, please set Pr.08-10=1 for magnetic pole re-orientation.

2. Smooth test for general operation

- Adjust the setting of Pr.11-05

Pr.11-05 Inertial Ratio	1~300%
----------------------------	--------

- Adjust the settings of Pr.11-06 to Pr.11-08

Settings of Pr.11-06 to Pr.11-08	Zero-speed Bandwidth	0~40Hz
	Low-speed Bandwidth	0~40Hz
	High-speed Bandwidth	0~40Hz

3. Start-up adjustment (only for PM)

- Control by the zero-speed position

Setting Pr.11-00, 10-19, 10-22, 10-23, 02-29 and 10-24

Pr.11-00 System control	Bit 0=0: disable Bit 0=1: ASR Auto tuning, PDFF enable Bit 7=1: When position control is enabled, it doesn't need to set Pr.07-02 (DC Brake Current Level) Bit 15=0: when power is applied, it will detect the position of magnetic pole again Bit 15=1: when power is applied, it will start from the magnetic pole position of previous power failure
Pr.10-19 Zero Speed Gain (P)	0~655.00%

NOTE: refer to the explanations in Pr.02-32

Pr.10-22 Operation Time of Zero Speed	0.000~65.535sec
--	-----------------

Pr.10-23 Filter Time of Zero Speed	0.000~65.535sec
---------------------------------------	-----------------

Pr.10-24 Time for Zero Speed Execution	0: after the brake release set in Pr.02-29 1: after the brake signal input (Pr.02-01~02-08 is set to 42)
---	---

Pr.02-29 Brake Release Delay Time when Elevator Starts	0.000~65.000 Sec
---	------------------

NOTE: When Pr.10-24=0, the zero speed control needs to be used with Pr.02-29. (refer to the explanations in Pr.02-32)

■ Function of the preload input

Connect the signal of the preload signal to the external terminal of the AC motor drive (AUI1) and setting Pr.03-00=11, 07-19=1, 03-03, 03-06 and 03-09.

Pr.03-00 Analog Input 1 (AUI1)	0: No function 1: Frequency command (torque limit under TQR control mode) 2: Torque command (torque limit under speed mode) 3: Torque compensation command 4-5: Reserved 6: P.T.C. thermistor input value 7: Positive torque limit 8: Negative torque limit 9: Regenerative torque limit 10: Positive/negative torque limit
-----------------------------------	--

Pr.07-19 Source of Torque Offset	0: Disable 1: Analog input (Pr.03-00) 2: Torque offset setting (Pr.07-20) 3: Control by external terminal (by Pr.07-21 to Pr.07-23)
-------------------------------------	--

Pr.03-03 Analog Input Bias 1 (AUI1)	-100.0~100.0%
--	---------------

Pr.03-06 Positive/negative Bias Mode (AUI1)	0: Zero bias 1: Lower than bias=bias 2: Greater than bias=bias 3: The absolute value of the bias voltage while serving as the center 4: Serve bias as the center
--	--

Pr.03-09 Analog Input Gain 1 (AUI1)	-500.0~500.0%
--	---------------

NOTE: Pr.03-03, 03-06 and 03-09 are used to adjust the analog input signal.

- 07-19: Source of torque offset
- 03-00~02: Analog input selections (AUI1/ACI/AUI2)
- 03-03~05: Analog input bias (AUI1/ACI/AUI2)
- 03-06~08: AUI1/ACI/AUI2 bias mode

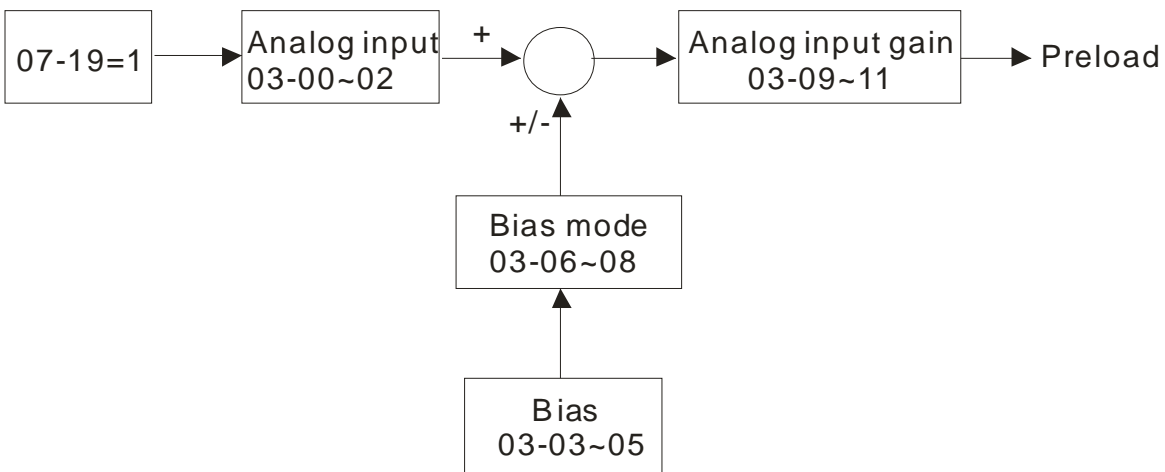

4. Setting of drive stop

Adjusting Pr.01-29, Pr.01-30, Pr.01-31 and Pr.11-06

Pr.01-29 Switch Frequency for S3/S4 Changes to S5	0.00~400.00Hz
Pr.01-30 S-curve for Deceleration Arrival Time S5	0.00~25.00 sec
Pr.11-06 Zero-speed Bandwidth	0~40Hz
Pr.01-31 Deceleration Time	0.00~600.00 sec

11 Summary of Parameter Settings

This chapter provides summary of parameter settings for user to gather the parameter setting ranges, factory settings and set parameters. The parameters can be set, changed and reset by the digital keypad.

NOTE

- 1) : the parameter can be set during operation
- 2) For more detail on parameters, please refer to Ch12 Description of Parameter Settings.

00 Drive Parameters

 NOTE IM: Induction Motor; PM: Permanent Magnet Motor

Pr.	Explanation	Setting Range	Factory Setting	VF	VFP	SVC	FOCPG	TQCPG	FOCPM
				<input type="radio"/>	<input type="radio"/>	<input type="radio"/>	<input type="radio"/>	<input type="radio"/>	<input type="radio"/>
00-00	Identity Code of the AC Motor Drive	108 : 220V · 3HP (single phase) 110 : 220V · 5HP (Single phase) 8 : 230V · 3HP 10 : 230V · 5HP 11 : 460 V · 5HP (4.0kW) 12 : 230V · 7.5HP 13 : 460 V · 7.5HP 14 : 230V, 10HP 15 : 460V, 10HP 16 : 230V, 15HP 17 : 460V, 15HP 18 : 230V, 20HP 19 : 460V, 20HP 20 : 230V, 25HP 21 : 460V, 25HP 22 : 230V, 30HP 23 : 460V, 30HP 24 : 230V, 40HP 25 : 460V, 40HP 26 : 230V, 50HP 27 : 460V, 50HP 29 : 460V, 60HP 31 : 460V, 75HP 33 : 460V, 100HP	Read Only	<input type="radio"/>	<input type="radio"/>	<input type="radio"/>	<input type="radio"/>	<input type="radio"/>	<input type="radio"/>
00-01	Display AC Motor Drive Rated Current	Display by models	Read only	<input type="radio"/>	<input type="radio"/>	<input type="radio"/>	<input type="radio"/>	<input type="radio"/>	<input type="radio"/>
00-02	Parameter Reset	0: No function 1: Read only 8: No function 9: All parameters are reset to factory settings(base frequency is 50Hz) 10: All parameters are reset to factory settings (base frequency is 60Hz)	0	<input type="radio"/>	<input type="radio"/>	<input type="radio"/>	<input type="radio"/>	<input type="radio"/>	<input type="radio"/>

Pr.	Explanation	Setting Range	Factory Setting	VF	VFP	SVC	FOCPG	TQCPG	FOCPM
00-03	Start-up Display Selection	0: Frequency command 1: Output frequency 2: DC BUS voltage 3: Output current 4: Output voltage 5: User defined (00-04)	0	<input type="radio"/>	<input type="radio"/>	<input type="radio"/>	<input type="radio"/>	<input type="radio"/>	<input type="radio"/>
00-04	Content of Multi-function Display	0: Display output current (A) (Unit: Amps) 1: Reserved 2: Display actual output frequency (H.) (Unit: Hz) 3: Display DC-BUS voltage (v) (Unit: Vdc) 4: Display output voltage (E) (Unit: Vac) 5: Display output power angle (n) (Unit: deg) 6: Display output power in kW (P) (Unit: kW) 7: Display actual motor speed rpm (r) (Unit: rpm) 8: Display estimate output torque % (t) (Unit: %) 9: Display PG feedback (G) (refer to Pr.10-00,10-01) (Unit: PLS) 10: Display PID feedback (b) (Unit: %) 11: Display AUI1 in % (1.) (Unit: %) 12: Reserved 13: Display AUI2 in % (2.) (Unit: %) 14: Display the temperature of heat sink in °C (c.) (Unit: °C) 15: Display the temperature of IGBT in °C (c.) (Unit: °C) 16: The status of digital input (ON/OFF) (i) 17: The status of digital output (ON/OFF) (o) 18: Multi-step speed (S) 19: The corresponding CPU pin status of digital input (d)	0	<input type="radio"/>	<input type="radio"/>	<input type="radio"/>	<input type="radio"/>	<input type="radio"/>	<input type="radio"/>

		20: The corresponding CPU pin status of digital output (0.) 21~23: Reserved 24: AC output voltage when error occurred 25: DC-side voltage when error occurred 26: Motor's frequency when error occurred 27: Output current when error occurred 28: Output frequency when error occurred 29: Frequency command when error occurred 30: Output power when error occurred 31: Output torque when error occurred 32: Input terminal status when error occurred 33: Output terminal status when error occurred 34: Status of motor drive when error occurred 35: Display MI status & MO status on LED keypad.								
✓	00-05	User-Defined Coefficient K	Digit 4: decimal point number (0 to 3) Digit 3-0: 40 to 9999	0	<input type="radio"/>	<input type="radio"/>	<input type="radio"/>	<input type="radio"/>	<input type="radio"/>	<input type="radio"/>
	00-06	Software Version	READ ONLY	#. #	<input type="radio"/>	<input type="radio"/>	<input type="radio"/>	<input type="radio"/>	<input type="radio"/>	<input type="radio"/>
✓	00-07	Password Input	1 to 9998 and 10000 to 65535 0 to 2: times of wrong password	0	<input type="radio"/>	<input type="radio"/>	<input type="radio"/>	<input type="radio"/>	<input type="radio"/>	<input type="radio"/>
✓	00-08	Password Set	1 to 9998 and 10000 to 65535 0: No password set or successful input in Pr.00-07 1: Password has been set	0	<input type="radio"/>	<input type="radio"/>	<input type="radio"/>	<input type="radio"/>	<input type="radio"/>	<input type="radio"/>
	00-09	Control Method	0: V/f Control 1: V/f Control + Encoder (VFPG) 2: Sensorless vector control (SVC) 3: FOC vector control + Encoder (FOCPG) 4: Torque control + Encoder (TQCPG) 8: FOC PM control (FOCPM)	0	<input type="radio"/>	<input type="radio"/>	<input type="radio"/>	<input type="radio"/>	<input type="radio"/>	<input type="radio"/>
✓	00-10	Speed Unit	0: Hz 1: m/s 2: ft/s	0	<input type="radio"/>	<input type="radio"/>	<input type="radio"/>	<input type="radio"/>	<input type="radio"/>	<input type="radio"/>
	00-11	Output Direction Selection	0: FWD: counterclockwise, REV: clockwise 1: FWD: clockwise, REV: counterclockwise	0	<input type="radio"/>	<input type="radio"/>	<input type="radio"/>	<input type="radio"/>	<input type="radio"/>	<input type="radio"/>
✓	00-12	Carrier Frequency	2~15KHz	12	<input type="radio"/>	<input type="radio"/>	<input type="radio"/>	<input type="radio"/>	<input type="radio"/>	<input type="radio"/>
✓	00-13	Auto Voltage Regulation (AVR) Function	0: Enable AVR 1: Disable AVR 2: Disable AVR when deceleration stop	0	<input type="radio"/>	<input type="radio"/>	<input type="radio"/>	<input type="radio"/>	<input type="radio"/>	<input type="radio"/>
✓	00-14	Source of the Master Frequency Command	1: RS-485 serial communication or digital keypad (KPC-CC01) 2: External analog input (Pr. 03-00) 3: Digital terminals input (Pr. 04-00~04-15)	1	<input type="radio"/>	<input type="radio"/>	<input type="radio"/>	<input type="radio"/>	<input type="radio"/>	<input type="radio"/>
✓	00-15	Source of the Operation Command	1: External terminals 2: RS-485 serial communication or digital keypad (KPC-CC01)	1	<input type="radio"/>	<input type="radio"/>	<input type="radio"/>	<input type="radio"/>	<input type="radio"/>	<input type="radio"/>

01 Basic Parameters

Pr.	Explanation	Setting Range	Factory Setting	V/F	V/PG	SVC	FOCPG	TQCPG	FOCPM
				<input type="checkbox"/>	<input type="checkbox"/>	<input type="checkbox"/>	<input type="checkbox"/>	<input type="checkbox"/>	<input type="checkbox"/>
01-00	Maximum Output Frequency	10.00~400.00Hz	60.00/ 50.00	<input type="checkbox"/>	<input type="checkbox"/>	<input type="checkbox"/>	<input type="checkbox"/>	<input type="checkbox"/>	<input type="checkbox"/>
01-01	1st Output Frequency Setting 1 (base frequency /motor's rated frequency)	0.00~400.00Hz	60.00/ 50.00	<input type="checkbox"/>	<input type="checkbox"/>	<input type="checkbox"/>	<input type="checkbox"/>	<input type="checkbox"/>	<input type="checkbox"/>
01-02	1st Output Voltage Setting 1 (base voltage/ motor's rated voltage)	230V serie: 0.0V~255.0V 460V serie: 0.0V~510.0V	220.0 440.0	<input type="checkbox"/>	<input type="checkbox"/>	<input type="checkbox"/>	<input type="checkbox"/>	<input type="checkbox"/>	<input type="checkbox"/>
01-03	2 nd Output Frequency Setting 1	0.00~400.00Hz	0.50	<input type="checkbox"/>	<input type="checkbox"/>				
✓ 01-04	2 nd Output Voltage Setting 1	230V serie: 0.0V~255.0V 460V serie: 0.0V~510.0V	5.0 10.0	<input type="checkbox"/>	<input type="checkbox"/>				
01-05	3 rd Output Frequency Setting 1	0.00~400.00Hz	0.50	<input type="checkbox"/>	<input type="checkbox"/>				
✓ 01-06	3 rd Output Voltage Setting 1	230V serie: 0.0V~255.0V 460V serie: 0.0V~510.0V	5.0 10.0	<input type="checkbox"/>	<input type="checkbox"/>				
01-07	4 th Output Frequency Setting 1	0.00~400.00Hz	0.00	<input type="checkbox"/>	<input type="checkbox"/>	<input type="checkbox"/>	<input type="checkbox"/>	<input type="checkbox"/>	
✓ 01-08	4 th Output Voltage Setting 1	230V serie: 0.0V~255.0V 460V serie: 0.0V~510.0V	5.0 10.0	<input type="checkbox"/>	<input type="checkbox"/>				
01-09	Starting Frequency	0.00~400.00Hz	0.50	<input type="checkbox"/>	<input type="checkbox"/>	<input type="checkbox"/>	<input type="checkbox"/>		
✓ 01-10	Output Frequency Upper Limit	0.00~400.00Hz	120.00	<input type="checkbox"/>	<input type="checkbox"/>	<input type="checkbox"/>	<input type="checkbox"/>		<input type="checkbox"/>
✓ 01-11	Output Frequency Lower Limit	0.00~400.00Hz	0.00	<input type="checkbox"/>	<input type="checkbox"/>	<input type="checkbox"/>	<input type="checkbox"/>		<input type="checkbox"/>
✓ 01-12	Accel Time 1	0.00~600.00 sec.	3.00	<input type="checkbox"/>	<input type="checkbox"/>	<input type="checkbox"/>	<input type="checkbox"/>		<input type="checkbox"/>
✓ 01-13	Decel Time 1	0.00~600.00 sec	2.00	<input type="checkbox"/>	<input type="checkbox"/>	<input type="checkbox"/>	<input type="checkbox"/>		<input type="checkbox"/>
✓ 01-14	Accel Time 2	0.00~600.00 sec	3.00	<input type="checkbox"/>	<input type="checkbox"/>	<input type="checkbox"/>	<input type="checkbox"/>		<input type="checkbox"/>
✓ 01-15	Decel Time 2	0.00~600.00 sec	2.00	<input type="checkbox"/>	<input type="checkbox"/>	<input type="checkbox"/>	<input type="checkbox"/>		<input type="checkbox"/>
✓ 01-16	Accel Time 3	0.00~600.00 sec	3.00	<input type="checkbox"/>	<input type="checkbox"/>	<input type="checkbox"/>	<input type="checkbox"/>		<input type="checkbox"/>
✓ 01-17	Decel Time 3	0.00~600.00 sec	2.00	<input type="checkbox"/>	<input type="checkbox"/>	<input type="checkbox"/>	<input type="checkbox"/>		<input type="checkbox"/>
✓ 01-18	Accel Time 4	0.00~600.00 sec	3.00	<input type="checkbox"/>	<input type="checkbox"/>	<input type="checkbox"/>	<input type="checkbox"/>		<input type="checkbox"/>
✓ 01-19	Decel Time 4	0.00~600.00 sec	2.00	<input type="checkbox"/>	<input type="checkbox"/>	<input type="checkbox"/>	<input type="checkbox"/>		<input type="checkbox"/>
✓ 01-20	JOG Acceleration Time	0.00~600.00 sec	1.00	<input type="checkbox"/>	<input type="checkbox"/>	<input type="checkbox"/>	<input type="checkbox"/>		<input type="checkbox"/>
✓ 01-21	JOG Deceleration Time	0.00~600.00 sec	1.00	<input type="checkbox"/>	<input type="checkbox"/>	<input type="checkbox"/>	<input type="checkbox"/>		<input type="checkbox"/>
✓ 01-22	JOG Frequency	0.00~400.00Hz	6.00	<input type="checkbox"/>	<input type="checkbox"/>	<input type="checkbox"/>	<input type="checkbox"/>	<input type="checkbox"/>	<input type="checkbox"/>
✓ 01-23	Switch Frequency between 1st/4th Accel/dec	0.00~400.00Hz	0.00	<input type="checkbox"/>	<input type="checkbox"/>	<input type="checkbox"/>	<input type="checkbox"/>		<input type="checkbox"/>
✓ 01-24	S-curve for Acceleration Departure Time S1	0.00~25.00 sec	1.00	<input type="checkbox"/>	<input type="checkbox"/>	<input type="checkbox"/>	<input type="checkbox"/>		<input type="checkbox"/>
✓ 01-25	S-curve for Acceleration Arrival Time S2	0.00~25.00 sec	1.00	<input type="checkbox"/>	<input type="checkbox"/>	<input type="checkbox"/>	<input type="checkbox"/>		<input type="checkbox"/>
✓ 01-26	S-curve for Deceleration Departure Time S3	0.00~25.00sec.	1.00	<input type="checkbox"/>	<input type="checkbox"/>	<input type="checkbox"/>	<input type="checkbox"/>		<input type="checkbox"/>
✓ 01-27	S-curve for Deceleration Arrival Time S4	0.00~25.00sec.	1.00	<input type="checkbox"/>	<input type="checkbox"/>	<input type="checkbox"/>	<input type="checkbox"/>		<input type="checkbox"/>
01-28	Mode of Selection when Frequency < Fmin	0: Output waiting 1: Zero-speed operation 2: Fmin (4th output frequency setting)	1	<input type="checkbox"/>	<input type="checkbox"/>	<input type="checkbox"/>			
✓ 01-29	Switch Frequency for S3/S4 Changes to S5	0.00~400.00Hz	0.00	<input type="checkbox"/>	<input type="checkbox"/>	<input type="checkbox"/>	<input type="checkbox"/>		<input type="checkbox"/>
✓ 01-30	S-curve for Deceleration Arrival Time S5	0.00~25.00sec.	1.00	<input type="checkbox"/>	<input type="checkbox"/>	<input type="checkbox"/>	<input type="checkbox"/>		<input type="checkbox"/>

↗ 01-31	Deceleration Time when Operating without RUN Command	0.00~600.00sec.	2.00	<input type="radio"/>	<input type="radio"/>	<input type="radio"/>	<input type="radio"/>	<input type="radio"/>	<input type="radio"/>
---------	--	-----------------	------	-----------------------	-----------------------	-----------------------	-----------------------	-----------------------	-----------------------

02 Digital Input/ Output Parametes

Pr.	Explanation	Setting Range	Factory Setting	VF	VFG	SVC	FOCPG	TQCPG	FOCPM
02-00	2-wire/3-wire Operation Control	0: FWD/STOP, REV/STOP 1: FWD/STOP, REV/STOP (Line Start Lockout) 2: RUN/STOP, REV/FWD 3: RUN/STOP, REV/FWD (Line Start Lockout) 4: 3-wire 5: 3-wire (Line Start Lockout)	0	<input type="radio"/>	<input type="radio"/>	<input type="radio"/>	<input type="radio"/>	<input type="radio"/>	<input type="radio"/>
02-01	Multi-Function Input Command 1 (MI1) (it is Stop terminal for 3-wire operation)	0: no function	1	<input type="radio"/>	<input type="radio"/>	<input type="radio"/>	<input type="radio"/>	<input type="radio"/>	<input type="radio"/>
		1: multi-step speed command 1		<input type="radio"/>	<input type="radio"/>	<input type="radio"/>	<input type="radio"/>	<input type="radio"/>	<input type="radio"/>
02-02	Multi-Function Input Command 2 (MI2)	2: multi-step speed command 2	2	<input type="radio"/>	<input type="radio"/>	<input type="radio"/>	<input type="radio"/>	<input type="radio"/>	<input type="radio"/>
02-03	Multi-Function Input Command 3 (MI3)	3: multi-step speed command 3	3	<input type="radio"/>	<input type="radio"/>	<input type="radio"/>	<input type="radio"/>	<input type="radio"/>	<input type="radio"/>
02-04	Multi-Function Input Command 4 (MI4)	4: multi-step speed command 4	4	<input type="radio"/>	<input type="radio"/>	<input type="radio"/>	<input type="radio"/>	<input type="radio"/>	<input type="radio"/>
02-05	Multi-Function Input Command 5 (MI5)	5: Reset	0	<input type="radio"/>	<input type="radio"/>	<input type="radio"/>	<input type="radio"/>	<input type="radio"/>	<input type="radio"/>
02-06	Multi-Function Input Command 6 (MI6)	6: JOG command	0	<input type="radio"/>	<input type="radio"/>	<input type="radio"/>	<input type="radio"/>	<input type="radio"/>	<input type="radio"/>
02-07	Multi-Function Input Command 7 (MI7)	7: acceleration/deceleration speed inhibit	0	<input type="radio"/>	<input type="radio"/>	<input type="radio"/>	<input type="radio"/>	<input type="radio"/>	<input type="radio"/>
02-08	Multi-Function Input Command 8 (MI8)	8: the 1st, 2nd acceleration/deceleration time selection	40	<input type="radio"/>	<input type="radio"/>	<input type="radio"/>	<input type="radio"/>	<input type="radio"/>	<input type="radio"/>
		9: the 3rd, 4th acceleration/deceleration time selection		<input type="radio"/>	<input type="radio"/>	<input type="radio"/>	<input type="radio"/>	<input type="radio"/>	<input type="radio"/>
		10: EF input (07-28)		<input type="radio"/>	<input type="radio"/>	<input type="radio"/>	<input type="radio"/>	<input type="radio"/>	<input type="radio"/>
		11: Reserved		<input type="radio"/>	<input type="radio"/>	<input type="radio"/>	<input type="radio"/>	<input type="radio"/>	<input type="radio"/>
		12: Stop output		<input type="radio"/>	<input type="radio"/>	<input type="radio"/>	<input type="radio"/>	<input type="radio"/>	<input type="radio"/>
		13~14: Reserved		<input type="radio"/>	<input type="radio"/>	<input type="radio"/>	<input type="radio"/>	<input type="radio"/>	<input type="radio"/>
		15: operation speed command form AUI1		<input type="radio"/>	<input type="radio"/>	<input type="radio"/>	<input type="radio"/>	<input type="radio"/>	<input type="radio"/>
		16: Reserved		<input type="radio"/>	<input type="radio"/>	<input type="radio"/>	<input type="radio"/>	<input type="radio"/>	<input type="radio"/>
		17: Operation speed command form AUI2		<input type="radio"/>	<input type="radio"/>	<input type="radio"/>	<input type="radio"/>	<input type="radio"/>	<input type="radio"/>
		18: Emergency Stop (07-28)		<input type="radio"/>	<input type="radio"/>	<input type="radio"/>	<input type="radio"/>	<input type="radio"/>	<input type="radio"/>
		19~23: Reserved		<input type="radio"/>	<input type="radio"/>	<input type="radio"/>	<input type="radio"/>	<input type="radio"/>	<input type="radio"/>
		24: FWD JOG command		<input type="radio"/>	<input type="radio"/>	<input type="radio"/>	<input type="radio"/>	<input type="radio"/>	<input type="radio"/>
		25: REV JOG command		<input type="radio"/>	<input type="radio"/>	<input type="radio"/>	<input type="radio"/>	<input type="radio"/>	<input type="radio"/>
		26: Reserved		<input type="radio"/>	<input type="radio"/>	<input type="radio"/>	<input type="radio"/>	<input type="radio"/>	<input type="radio"/>
		27: ASR1/ASR2 selection		<input type="radio"/>	<input type="radio"/>	<input type="radio"/>	<input type="radio"/>	<input type="radio"/>	<input type="radio"/>
		28: Emergency stop (EF1) (Motor coasts to stop)		<input type="radio"/>	<input type="radio"/>	<input type="radio"/>	<input type="radio"/>	<input type="radio"/>	<input type="radio"/>
		29-30: Reserved		<input type="radio"/>	<input type="radio"/>	<input type="radio"/>	<input type="radio"/>	<input type="radio"/>	<input type="radio"/>
		31: High torque bias (by Pr.07-21)		<input type="radio"/>	<input type="radio"/>	<input type="radio"/>	<input type="radio"/>	<input type="radio"/>	<input type="radio"/>
		32: Middle torque bias (by Pr.07-22)		<input type="radio"/>	<input type="radio"/>	<input type="radio"/>	<input type="radio"/>	<input type="radio"/>	<input type="radio"/>
		33: Low torque bias (by Pr.07-23)		<input type="radio"/>	<input type="radio"/>	<input type="radio"/>	<input type="radio"/>	<input type="radio"/>	<input type="radio"/>
		34-37: Reserved		<input type="radio"/>	<input type="radio"/>	<input type="radio"/>	<input type="radio"/>	<input type="radio"/>	<input type="radio"/>
38: Disable write EEPROM function	<input type="radio"/>	<input type="radio"/>	<input type="radio"/>	<input type="radio"/>	<input type="radio"/>	<input type="radio"/>			
39: Torque command direction	<input type="radio"/>	<input type="radio"/>	<input type="radio"/>	<input type="radio"/>	<input type="radio"/>	<input type="radio"/>			
40: Enable drive function	<input type="radio"/>	<input type="radio"/>	<input type="radio"/>	<input type="radio"/>	<input type="radio"/>	<input type="radio"/>			
41: Detection of magnetic contactor	<input type="radio"/>	<input type="radio"/>	<input type="radio"/>	<input type="radio"/>	<input type="radio"/>	<input type="radio"/>			
42: Mechanical brake	<input type="radio"/>	<input type="radio"/>	<input type="radio"/>	<input type="radio"/>	<input type="radio"/>	<input type="radio"/>			
43: EPS function	<input type="radio"/>	<input type="radio"/>	<input type="radio"/>	<input type="radio"/>	<input type="radio"/>	<input type="radio"/>			

↗	02-09	Digital Input Response Time	0.001~ 30.000sec.	0.005	<input type="checkbox"/>	<input type="checkbox"/>	<input type="checkbox"/>	<input type="checkbox"/>	<input type="checkbox"/>	<input type="checkbox"/>
↗	02-10	Digital Input Operation Direction	0~65535	0	<input type="checkbox"/>	<input type="checkbox"/>	<input type="checkbox"/>	<input type="checkbox"/>	<input type="checkbox"/>	<input type="checkbox"/>
↗	02-11	Multi-function Output 1 RA, RB, RC(Relay1)	0: No function	11	<input type="checkbox"/>	<input type="checkbox"/>	<input type="checkbox"/>	<input type="checkbox"/>	<input type="checkbox"/>	<input type="checkbox"/>
			1: Operation indication		<input type="checkbox"/>	<input type="checkbox"/>	<input type="checkbox"/>	<input type="checkbox"/>	<input type="checkbox"/>	<input type="checkbox"/>
↗	02-12	Multi-function Output 2 MRA, MRC (Relay2)	2: Operation speed attained	1	<input type="checkbox"/>	<input type="checkbox"/>	<input type="checkbox"/>	<input type="checkbox"/>	<input type="checkbox"/>	<input type="checkbox"/>
			3: Desired frequency attained 1 (Pr.02-25)		<input type="checkbox"/>	<input type="checkbox"/>	<input type="checkbox"/>	<input type="checkbox"/>	<input type="checkbox"/>	<input type="checkbox"/>
			4: Desired frequency attained 2 (Pr.02-27)		<input type="checkbox"/>	<input type="checkbox"/>	<input type="checkbox"/>	<input type="checkbox"/>	<input type="checkbox"/>	<input type="checkbox"/>
↗	02-13	Multi-function Output 3 (Relay3)	5: Zero speed (frequency command)	0	<input type="checkbox"/>	<input type="checkbox"/>	<input type="checkbox"/>	<input type="checkbox"/>	<input type="checkbox"/>	<input type="checkbox"/>
↗	02-14	Multi-function Output 4 (Relay4)	6: Zero speed with stop (frequency command)	0	<input type="checkbox"/>	<input type="checkbox"/>	<input type="checkbox"/>	<input type="checkbox"/>	<input type="checkbox"/>	<input type="checkbox"/>
↗	02-15	Multi-fucntion Output 5 (MO1)	7: Over torque (OT1) (Pr.06-05~06-07)	0	<input type="checkbox"/>	<input type="checkbox"/>	<input type="checkbox"/>	<input type="checkbox"/>	<input type="checkbox"/>	<input type="checkbox"/>
↗	02-16	Multi-function Output 6 (MO2)	8: Over torque (OT2) (Pr.06-08~06-10)	0	<input type="checkbox"/>	<input type="checkbox"/>	<input type="checkbox"/>	<input type="checkbox"/>	<input type="checkbox"/>	<input type="checkbox"/>
			9: Drive ready	0	<input type="checkbox"/>	<input type="checkbox"/>	<input type="checkbox"/>	<input type="checkbox"/>	<input type="checkbox"/>	<input type="checkbox"/>
			10: User-defined Low-voltage Detection (LV)	0	<input type="checkbox"/>	<input type="checkbox"/>	<input type="checkbox"/>	<input type="checkbox"/>	<input type="checkbox"/>	<input type="checkbox"/>
			11: Malfunction indication	0	<input type="checkbox"/>	<input type="checkbox"/>	<input type="checkbox"/>	<input type="checkbox"/>	<input type="checkbox"/>	<input type="checkbox"/>
			12: Mechanical brake release (Pr.02-29, Pr.02-30)	0	<input type="checkbox"/>	<input type="checkbox"/>	<input type="checkbox"/>	<input type="checkbox"/>	<input type="checkbox"/>	<input type="checkbox"/>
			13: Overheat (Pr.06-14)	0	<input type="checkbox"/>	<input type="checkbox"/>	<input type="checkbox"/>	<input type="checkbox"/>	<input type="checkbox"/>	<input type="checkbox"/>
			14: Brake chopper signal		<input type="checkbox"/>	<input type="checkbox"/>	<input type="checkbox"/>	<input type="checkbox"/>	<input type="checkbox"/>	<input type="checkbox"/>
			15: Motor-controlled magnetic contactor output		<input type="checkbox"/>	<input type="checkbox"/>	<input type="checkbox"/>	<input type="checkbox"/>	<input type="checkbox"/>	<input type="checkbox"/>
			16: Slip error (oSL)		<input type="checkbox"/>	<input type="checkbox"/>	<input type="checkbox"/>	<input type="checkbox"/>	<input type="checkbox"/>	<input type="checkbox"/>
			17: Malfunction indication 1	0	<input type="checkbox"/>	<input type="checkbox"/>	<input type="checkbox"/>	<input type="checkbox"/>	<input type="checkbox"/>	<input type="checkbox"/>
			18: Reserved							
			19: Brake chopper output error		<input type="checkbox"/>	<input type="checkbox"/>	<input type="checkbox"/>	<input type="checkbox"/>	<input type="checkbox"/>	<input type="checkbox"/>
			20: Warning output		<input type="checkbox"/>	<input type="checkbox"/>	<input type="checkbox"/>	<input type="checkbox"/>	<input type="checkbox"/>	<input type="checkbox"/>
			21: Over voltage warning		<input type="checkbox"/>	<input type="checkbox"/>	<input type="checkbox"/>	<input type="checkbox"/>	<input type="checkbox"/>	<input type="checkbox"/>
			22: Over-current stall prevention warning		<input type="checkbox"/>	<input type="checkbox"/>	<input type="checkbox"/>	<input type="checkbox"/>	<input type="checkbox"/>	<input type="checkbox"/>
			23: Over-voltage stall prevention warning		<input type="checkbox"/>	<input type="checkbox"/>	<input type="checkbox"/>	<input type="checkbox"/>	<input type="checkbox"/>	<input type="checkbox"/>
			24: Operation mode indication (Pr.00-15≠0 and PU LED on KPC-CC01 is off)		<input type="checkbox"/>	<input type="checkbox"/>	<input type="checkbox"/>	<input type="checkbox"/>	<input type="checkbox"/>	<input type="checkbox"/>
			25: Forward command		<input type="checkbox"/>	<input type="checkbox"/>	<input type="checkbox"/>	<input type="checkbox"/>	<input type="checkbox"/>	<input type="checkbox"/>
			26: Reverse command		<input type="checkbox"/>	<input type="checkbox"/>	<input type="checkbox"/>	<input type="checkbox"/>	<input type="checkbox"/>	<input type="checkbox"/>
			27: Output when current >= Pr.02-33		<input type="checkbox"/>	<input type="checkbox"/>	<input type="checkbox"/>	<input type="checkbox"/>	<input type="checkbox"/>	<input type="checkbox"/>
			28: Output when current < Pr.02-33		<input type="checkbox"/>	<input type="checkbox"/>	<input type="checkbox"/>	<input type="checkbox"/>	<input type="checkbox"/>	<input type="checkbox"/>
			29: Output when frequency >= Pr.02-34		<input type="checkbox"/>	<input type="checkbox"/>	<input type="checkbox"/>	<input type="checkbox"/>	<input type="checkbox"/>	<input type="checkbox"/>
			30: Output when frequency < Pr.02-34		<input type="checkbox"/>	<input type="checkbox"/>	<input type="checkbox"/>	<input type="checkbox"/>	<input type="checkbox"/>	<input type="checkbox"/>
			31: Power generation direction and status verify		<input type="checkbox"/>	<input type="checkbox"/>	<input type="checkbox"/>	<input type="checkbox"/>	<input type="checkbox"/>	<input type="checkbox"/>
			32: Power generation direction		<input type="checkbox"/>	<input type="checkbox"/>	<input type="checkbox"/>	<input type="checkbox"/>	<input type="checkbox"/>	<input type="checkbox"/>
			33: Zero speed (actual output frequency)		<input type="checkbox"/>	<input type="checkbox"/>	<input type="checkbox"/>	<input type="checkbox"/>	<input type="checkbox"/>	<input type="checkbox"/>
			34: Zero speed with Stop (actual output frequency)		<input type="checkbox"/>	<input type="checkbox"/>	<input type="checkbox"/>	<input type="checkbox"/>	<input type="checkbox"/>	<input type="checkbox"/>
			35: Fault output option 1 (Pr.06-22)		<input type="checkbox"/>	<input type="checkbox"/>	<input type="checkbox"/>	<input type="checkbox"/>	<input type="checkbox"/>	<input type="checkbox"/>
			36: Fault output option 2 (Pr.06-23)		<input type="checkbox"/>	<input type="checkbox"/>	<input type="checkbox"/>	<input type="checkbox"/>	<input type="checkbox"/>	<input type="checkbox"/>
			37: Fault output option 3 (Pr.06-24)		<input type="checkbox"/>	<input type="checkbox"/>	<input type="checkbox"/>	<input type="checkbox"/>	<input type="checkbox"/>	<input type="checkbox"/>
			38: Fault output option 4 (Pr.06-25)		<input type="checkbox"/>	<input type="checkbox"/>	<input type="checkbox"/>	<input type="checkbox"/>	<input type="checkbox"/>	<input type="checkbox"/>
			39: Reserved							
			40: Speed attained (including zero speed)		<input type="checkbox"/>	<input type="checkbox"/>	<input type="checkbox"/>	<input type="checkbox"/>	<input type="checkbox"/>	<input type="checkbox"/>
			41: Reserved							
			42: SO Logice Output							
	02-17~	02-22	Reserved							
↗	02-23	Multi-output Direction	0~65535	0	<input type="checkbox"/>	<input type="checkbox"/>	<input type="checkbox"/>	<input type="checkbox"/>	<input type="checkbox"/>	<input type="checkbox"/>
	02-24	Serial Start Signal Selection	0: by FWD/REV; 1: by Enable	0	<input type="checkbox"/>	<input type="checkbox"/>	<input type="checkbox"/>	<input type="checkbox"/>	<input type="checkbox"/>	<input type="checkbox"/>
↗	02-25	Desired Frequency	0.00~400.00Hz	60.00/ 50.00	<input type="checkbox"/>	<input type="checkbox"/>	<input type="checkbox"/>	<input type="checkbox"/>	<input type="checkbox"/>	<input type="checkbox"/>

	Attained 1									
↘	02-26	The Width of the Desired Frequency Attained 1	0.00~400.00Hz	2.00	○	○	○	○		○
↘	02-27	Desired Frequency Attained 2	0.00~400.00Hz	60.00/ 50.00	○	○	○	○		○
↘	02-28	The Width of the Desired Frequency Attained 2	0.00~400.00Hz	2.00	○	○	○	○		○
	02-29	Brake Release Delay Time when Elevator Starts	0.000~65.000sec.	0.250	○	○	○	○	○	○
	02-30	Brake Engage Delay Time when Elevator Stops	0.000~65.000sec.	0.250	○	○	○	○	○	○
↘	02-31	Turn On Delay of Magnetic Contactor between Drive and Motor	0.000~65.000sec.	0.200	○	○	○	○	○	○
↘	02-32	Turn Off Delay of Magnetic Contactor between Drive and Motor	0.000~65.000sec.	0.200	○	○	○	○	○	○
↘	02-33	Output Current Level Setting for External Terminals	0~100%	0	○	○	○	○	○	○
↘	02-34	Output Boundary for External Terminals	0.00~+-400.00Hz (it is motor speed when using with PG)	0.00	○	○	○	○	○	○
↘	02-35	Detection Time of Mechanical Brake	0.00~10.00sec.	0.00	○	○	○	○	○	○
↘	02-36	Detection Time of Contactor	0.00~10.00sec.	0.00	○	○	○	○	○	○
	02-37	Check Torque Output Function	0: Enable 1: Disable	0	○	○	○	○	○	○

03 Analog Input/Output Parameter

Pr.	Explanation	Setting Range	Factory Setting	VF	VFG	SVC	FOCPG	TQCPG	FOCPM		
03-00	Analog Input 1 (AUI1)	0: No function	1	<input type="radio"/>	<input type="radio"/>	<input type="radio"/>	<input type="radio"/>	<input type="radio"/>	<input type="radio"/>		
03-01	Reserved	1: Frequency command (torque limit under TQR control mode)									
03-02	Analog Input 3 (AUI2)	2: Torque command (torque limit under speed mode)	0					<input type="radio"/>			
		3: Preload Input		<input type="radio"/>	<input type="radio"/>	<input type="radio"/>	<input type="radio"/>	<input type="radio"/>	<input type="radio"/>		
		4-5: Reserved									
		6: P.T.C. thermistor input value		<input type="radio"/>	<input type="radio"/>	<input type="radio"/>	<input type="radio"/>	<input type="radio"/>	<input type="radio"/>		
		7: Positive torque limit					<input type="radio"/>		<input type="radio"/>		
		8: Negative torque limit					<input type="radio"/>		<input type="radio"/>		
		9: Regenerative torque limit					<input type="radio"/>		<input type="radio"/>		
		10: Positive/negative torque limit					<input type="radio"/>		<input type="radio"/>		
		03-03		Analog Input Bias 1 (AUI1)	-100.0~100.0%	0.0	<input type="radio"/>	<input type="radio"/>	<input type="radio"/>	<input type="radio"/>	<input type="radio"/>
		03-04		Reserved							
03-05	Analog Input Bias 3 (AUI2)	-100.0~100.0%	0.0	<input type="radio"/>	<input type="radio"/>	<input type="radio"/>	<input type="radio"/>	<input type="radio"/>			
03-06	Positive/negative Bias Mode (AUI1)	0: Zero bias	0	<input type="radio"/>	<input type="radio"/>	<input type="radio"/>	<input type="radio"/>	<input type="radio"/>			
03-07	Reserved	1: Serve bias as the center, lower than bias=bias									
03-08	Positive/negative Bias Mode (AUI2)	2: Serve bias as the center, greater than bias=bias 3: The absolute value of the bias voltage while serving as the center (single polar) 4: Serve bias as the center (single polar)	0	<input type="radio"/>	<input type="radio"/>	<input type="radio"/>	<input type="radio"/>	<input type="radio"/>			
03-09	Analog Input Gain 1 (AUI1)	0.0~500.0%	100.0	<input type="radio"/>	<input type="radio"/>	<input type="radio"/>	<input type="radio"/>	<input type="radio"/>			
03-10	Reserved										
03-11	Analog Input Gain 3 (AUI2)	0.0~500.0%	100.0	<input type="radio"/>	<input type="radio"/>	<input type="radio"/>	<input type="radio"/>	<input type="radio"/>			
03-12	Analog Input Delay Time (AUI1)	0.00~2.00sec.	0.01	<input type="radio"/>	<input type="radio"/>	<input type="radio"/>	<input type="radio"/>	<input type="radio"/>			
03-13	Reserved										
03-14	Analog Input Filter Time (AUI2)	0.00~2.00sec.	0.01	<input type="radio"/>	<input type="radio"/>	<input type="radio"/>	<input type="radio"/>	<input type="radio"/>			
03-15	Reserved										
03-16	Reserved										
03-17	Analog Output Selection 1	0: Output frequency (Hz)	0	<input type="radio"/>	<input type="radio"/>	<input type="radio"/>	<input type="radio"/>	<input type="radio"/>	<input type="radio"/>		
		1: Frequency command (Hz)		<input type="radio"/>	<input type="radio"/>	<input type="radio"/>	<input type="radio"/>	<input type="radio"/>			
		2: Motor speed (RPM)		<input type="radio"/>	<input type="radio"/>	<input type="radio"/>	<input type="radio"/>	<input type="radio"/>			
		3: Output current (rms)		<input type="radio"/>	<input type="radio"/>	<input type="radio"/>	<input type="radio"/>	<input type="radio"/>			
		4: Output voltage		<input type="radio"/>	<input type="radio"/>	<input type="radio"/>	<input type="radio"/>	<input type="radio"/>			
		5: DC Bus Voltage		<input type="radio"/>	<input type="radio"/>	<input type="radio"/>	<input type="radio"/>	<input type="radio"/>			
		6: Power factor		<input type="radio"/>	<input type="radio"/>	<input type="radio"/>	<input type="radio"/>	<input type="radio"/>			
		7: Power		<input type="radio"/>	<input type="radio"/>	<input type="radio"/>	<input type="radio"/>	<input type="radio"/>			
		8: Output torque		<input type="radio"/>	<input type="radio"/>	<input type="radio"/>	<input type="radio"/>	<input type="radio"/>			
		9: AUI1		<input type="radio"/>	<input type="radio"/>	<input type="radio"/>	<input type="radio"/>	<input type="radio"/>			
		10: ACI									
		11: AUI2		<input type="radio"/>	<input type="radio"/>	<input type="radio"/>	<input type="radio"/>	<input type="radio"/>			
		12: q-axis current		<input type="radio"/>	<input type="radio"/>	<input type="radio"/>	<input type="radio"/>	<input type="radio"/>			
		13: q-axis feedback value		<input type="radio"/>	<input type="radio"/>	<input type="radio"/>	<input type="radio"/>	<input type="radio"/>			
		14: d-axis current		<input type="radio"/>	<input type="radio"/>	<input type="radio"/>	<input type="radio"/>	<input type="radio"/>			
		15: d-axis feedback value		<input type="radio"/>	<input type="radio"/>	<input type="radio"/>	<input type="radio"/>	<input type="radio"/>			
		16: q-axis voltage		<input type="radio"/>	<input type="radio"/>	<input type="radio"/>	<input type="radio"/>	<input type="radio"/>			
17: d-axis voltage	<input type="radio"/>	<input type="radio"/>	<input type="radio"/>	<input type="radio"/>	<input type="radio"/>						

		18: Torque command		<input type="radio"/>	<input type="radio"/>	<input type="radio"/>	<input type="radio"/>	<input type="radio"/>	<input type="radio"/>
		19-20: Reserved							
		21: Power Output		<input type="radio"/>	<input type="radio"/>	<input type="radio"/>	<input type="radio"/>	<input type="radio"/>	<input type="radio"/>
↗	03-18	Analog Output Gain 1	0~200.0%	100.0	<input type="radio"/>	<input type="radio"/>	<input type="radio"/>	<input type="radio"/>	<input type="radio"/>
↗	03-19	Analog Output Value in REV Direction 1	0: Absolute value in REV direction 1: Output 0V in REV direction 2: Enable output voltage in REV direction	0	<input type="radio"/>	<input type="radio"/>	<input type="radio"/>	<input type="radio"/>	<input type="radio"/>
↗	03-20	Analog Output Selection 2	0: Output frequency (Hz)	0	<input type="radio"/>	<input type="radio"/>	<input type="radio"/>	<input type="radio"/>	<input type="radio"/>
		1: Frequency command (Hz)			<input type="radio"/>	<input type="radio"/>	<input type="radio"/>	<input type="radio"/>	<input type="radio"/>
		2: Motor speed (RPM)			<input type="radio"/>	<input type="radio"/>	<input type="radio"/>	<input type="radio"/>	<input type="radio"/>
		3: Output current (rms)			<input type="radio"/>	<input type="radio"/>	<input type="radio"/>	<input type="radio"/>	<input type="radio"/>
		4: Output voltage			<input type="radio"/>	<input type="radio"/>	<input type="radio"/>	<input type="radio"/>	<input type="radio"/>
		5: DC Bus Voltage			<input type="radio"/>	<input type="radio"/>	<input type="radio"/>	<input type="radio"/>	<input type="radio"/>
		6: Power factor			<input type="radio"/>	<input type="radio"/>	<input type="radio"/>	<input type="radio"/>	<input type="radio"/>
		7: Power			<input type="radio"/>	<input type="radio"/>	<input type="radio"/>	<input type="radio"/>	<input type="radio"/>
		8: Output torque			<input type="radio"/>	<input type="radio"/>	<input type="radio"/>	<input type="radio"/>	<input type="radio"/>
		9: AVI			<input type="radio"/>	<input type="radio"/>	<input type="radio"/>	<input type="radio"/>	<input type="radio"/>
		10: ACI							
		11: AUI			<input type="radio"/>	<input type="radio"/>	<input type="radio"/>	<input type="radio"/>	<input type="radio"/>
		12: q-axis current			<input type="radio"/>	<input type="radio"/>	<input type="radio"/>	<input type="radio"/>	<input type="radio"/>
		13: q-axis feedback value			<input type="radio"/>	<input type="radio"/>	<input type="radio"/>	<input type="radio"/>	<input type="radio"/>
		14: d-axis current			<input type="radio"/>	<input type="radio"/>	<input type="radio"/>	<input type="radio"/>	<input type="radio"/>
		15: d-axis feedback value			<input type="radio"/>	<input type="radio"/>	<input type="radio"/>	<input type="radio"/>	<input type="radio"/>
		16: q-axis voltage			<input type="radio"/>	<input type="radio"/>	<input type="radio"/>	<input type="radio"/>	<input type="radio"/>
		17: d-axis voltage			<input type="radio"/>	<input type="radio"/>	<input type="radio"/>	<input type="radio"/>	<input type="radio"/>
		18: Torque command			<input type="radio"/>	<input type="radio"/>	<input type="radio"/>	<input type="radio"/>	<input type="radio"/>
		19-20: Reserved							
		21: Power Output			<input type="radio"/>	<input type="radio"/>	<input type="radio"/>	<input type="radio"/>	<input type="radio"/>
↗	03-21	Analog Output Gain 2	0~200.0%	100.0	<input type="radio"/>	<input type="radio"/>	<input type="radio"/>	<input type="radio"/>	<input type="radio"/>
↗	03-22	Analog Output Value in REV Direction 2	0: Absolute value in REV direction 1: Output 0V in REV direction 2: Enable output voltage in REV direction	0	<input type="radio"/>	<input type="radio"/>	<input type="radio"/>	<input type="radio"/>	<input type="radio"/>
	03-23	Analog Input Type (AUI1)	0: Bipolar (±10V) 1: Unipolar (0-10V)	0	<input type="radio"/>	<input type="radio"/>	<input type="radio"/>	<input type="radio"/>	<input type="radio"/>
	03-24	Analog Input Type (AUI2)	0: Bipolar (±10V) 1: Unipolar (0-10V)	0	<input type="radio"/>	<input type="radio"/>	<input type="radio"/>	<input type="radio"/>	<input type="radio"/>

04 Multi-Step Speed Parameters

Pr.	Explanation	Setting Range	Factory Setting	VF	VFG	SVC	FOCPG	TQCPG	FOCPM
				<input type="radio"/>	<input type="radio"/>	<input type="radio"/>	<input type="radio"/>	<input type="radio"/>	<input type="radio"/>
↘ 04-00	Zero Step Speed Frequency	0.00~400.00Hz	0.00	<input type="radio"/>	<input type="radio"/>	<input type="radio"/>	<input type="radio"/>	<input type="radio"/>	<input type="radio"/>
↘ 04-01	1st Step Speed Frequency	0.00~400.00Hz	0.00	<input type="radio"/>	<input type="radio"/>	<input type="radio"/>	<input type="radio"/>	<input type="radio"/>	<input type="radio"/>
↘ 04-02	2nd Step Speed Frequency	0.00~400.00Hz	0.00	<input type="radio"/>	<input type="radio"/>	<input type="radio"/>	<input type="radio"/>	<input type="radio"/>	<input type="radio"/>
↘ 04-03	3rd Step Speed Frequency	0.00~400.00Hz	0.00	<input type="radio"/>	<input type="radio"/>	<input type="radio"/>	<input type="radio"/>	<input type="radio"/>	<input type="radio"/>
↘ 04-04	4th Step Speed Frequency	0.00~400.00Hz	0.00	<input type="radio"/>	<input type="radio"/>	<input type="radio"/>	<input type="radio"/>	<input type="radio"/>	<input type="radio"/>
↘ 04-05	5th Step Speed Frequency	0.00~400.00Hz	0.00	<input type="radio"/>	<input type="radio"/>	<input type="radio"/>	<input type="radio"/>	<input type="radio"/>	<input type="radio"/>
↘ 04-06	6th Step Speed Frequency	0.00~400.00Hz	0.00	<input type="radio"/>	<input type="radio"/>	<input type="radio"/>	<input type="radio"/>	<input type="radio"/>	<input type="radio"/>
↘ 04-07	7th Step Speed Frequency	0.00~400.00Hz	0.00	<input type="radio"/>	<input type="radio"/>	<input type="radio"/>	<input type="radio"/>	<input type="radio"/>	<input type="radio"/>
↘ 04-08	8th Step Speed Frequency	0.00~400.00Hz	0.00	<input type="radio"/>	<input type="radio"/>	<input type="radio"/>	<input type="radio"/>	<input type="radio"/>	<input type="radio"/>
↘ 04-09	9th Step Speed Frequency	0.00~400.00Hz	0.00	<input type="radio"/>	<input type="radio"/>	<input type="radio"/>	<input type="radio"/>	<input type="radio"/>	<input type="radio"/>
↘ 04-10	10th Step Speed Frequency	0.00~400.00Hz	0.00	<input type="radio"/>	<input type="radio"/>	<input type="radio"/>	<input type="radio"/>	<input type="radio"/>	<input type="radio"/>
↘ 04-11	11th Step Speed Frequency	0.00~400.00Hz	0.00	<input type="radio"/>	<input type="radio"/>	<input type="radio"/>	<input type="radio"/>	<input type="radio"/>	<input type="radio"/>
↘ 04-12	12th Step Speed Frequency	0.00~400.00Hz	0.00	<input type="radio"/>	<input type="radio"/>	<input type="radio"/>	<input type="radio"/>	<input type="radio"/>	<input type="radio"/>
↘ 04-13	13th Step Speed Frequency	0.00~400.00Hz	0.00	<input type="radio"/>	<input type="radio"/>	<input type="radio"/>	<input type="radio"/>	<input type="radio"/>	<input type="radio"/>
↘ 04-14	14th Step Speed Frequency	0.00~400.00Hz	0.00	<input type="radio"/>	<input type="radio"/>	<input type="radio"/>	<input type="radio"/>	<input type="radio"/>	<input type="radio"/>
↘ 04-15	15th Step Speed Frequency	0.00~400.00Hz	0.00	<input type="radio"/>	<input type="radio"/>	<input type="radio"/>	<input type="radio"/>	<input type="radio"/>	<input type="radio"/>

05 IM Parameters

Pr.	Explanation	Setting Range	Factory Setting	VF	VFP	SVC	FOCPG	TQCPG	FOCPM
05-00	Motor Auto Tuning	0: No function 1: Rolling test (Rs, Rr, Lm, Lx, no-load current) 2: Static test	0	<input type="radio"/>					
05-01	Full-load Current of Motor	(40~120%) *00-01 Amps	###	<input type="radio"/>	<input type="radio"/>	<input type="radio"/>	<input type="radio"/>	<input type="radio"/>	
05-02	Rated power of Motor	0.00~655.35kW	###			<input type="radio"/>	<input type="radio"/>	<input type="radio"/>	
05-03	Rated speed of Motor (rpm)	0~65535	1710		<input type="radio"/>	<input type="radio"/>	<input type="radio"/>	<input type="radio"/>	
05-04	Number of Motor Poles	2~48	4	<input type="radio"/>	<input type="radio"/>	<input type="radio"/>	<input type="radio"/>	<input type="radio"/>	
05-05	No-load Current of Motor	0~ Pr05-01 <factory setting>	###		<input type="radio"/>	<input type="radio"/>	<input type="radio"/>	<input type="radio"/>	
05-06	Rs of Motor	0.000~65.535Ω	0.000			<input type="radio"/>	<input type="radio"/>	<input type="radio"/>	
05-07	Rr of Motor	0.000~65.535Ω	0.000			<input type="radio"/>	<input type="radio"/>	<input type="radio"/>	
05-08	Lm of Motor	0.0~6553.5mH	0.0			<input type="radio"/>	<input type="radio"/>	<input type="radio"/>	
05-09	Lx of Motor	0.0~6553.5mH	0.0			<input type="radio"/>	<input type="radio"/>	<input type="radio"/>	
✓ 05-10	Torque Compensation Time Constant	0.001~10.000sec.	0.020			<input type="radio"/>			
✓ 05-11	Slip Compensation Time Constant	0.001~10.000sec.	0.100			<input type="radio"/>			
✓ 05-12	Torque Compensation Gain	0~10	0	<input type="radio"/>	<input type="radio"/>				
✓ 05-13	Slip Compensation Gain	0.00~10.00	0.00	<input type="radio"/>	<input type="radio"/>	<input type="radio"/>			
✓ 05-14	Slip Deviation Level	0~1000% (0: disable)	0		<input type="radio"/>	<input type="radio"/>	<input type="radio"/>		
✓ 05-15	Detection Time of Slip Deviation	0.0~10.0sec.	1.0		<input type="radio"/>	<input type="radio"/>	<input type="radio"/>		
✓ 05-16	Over Slip Treatment	0: Warn and keep operation 1: Warn and ramp to stop 2: Warn and coast to stop	0		<input type="radio"/>	<input type="radio"/>	<input type="radio"/>		
✓ 05-17	Hunting Gain	0~10000 (0: disable)	2000	<input type="radio"/>	<input type="radio"/>	<input type="radio"/>			
05-18	Accumulative Motor Operation Time (Min.)	00~1439	00	<input type="radio"/>	<input type="radio"/>	<input type="radio"/>	<input type="radio"/>	<input type="radio"/>	<input type="radio"/>
05-19	Accumulative Motor Operation Time (day)	00~65535	00	<input type="radio"/>	<input type="radio"/>	<input type="radio"/>	<input type="radio"/>	<input type="radio"/>	<input type="radio"/>
✓ 05-20	Core Loss Compensation	0~250%	10			<input type="radio"/>			
05-21	Accumulative Drive Power-on Time (Min.)	00~1439	00	<input type="radio"/>	<input type="radio"/>	<input type="radio"/>	<input type="radio"/>	<input type="radio"/>	<input type="radio"/>
05-22	Accumulative Drive Power-on Time (day)	00~65535	00	<input type="radio"/>	<input type="radio"/>	<input type="radio"/>	<input type="radio"/>	<input type="radio"/>	<input type="radio"/>

06 Protection Parameters

Pr.	Explanation	Setting Range	Factory Setting	VF	VFG	SVC	FOCPG	TQCPG	FOCPM
✓ 06-00	Low Voltage Level	160.0~220.0Vdc 320.0~440.0Vdc	180.0 360.0	<input type="radio"/>	<input type="radio"/>	<input type="radio"/>	<input type="radio"/>	<input type="radio"/>	<input type="radio"/>
✓ 06-01	Phase-loss protection	0: Fault and keep operation 1: Fault and ramp to stop 2: Fault and coast to stop	2	<input type="radio"/>	<input type="radio"/>	<input type="radio"/>	<input type="radio"/>	<input type="radio"/>	<input type="radio"/>
✓ 06-02	Over-Current Stall Prevention during Acceleration	00: disable 00~250%	00	<input type="radio"/>	<input type="radio"/>	<input type="radio"/>			
✓ 06-03	Over-current Stall Prevention during Operation	00: disable 00~250%	00	<input type="radio"/>	<input type="radio"/>	<input type="radio"/>			
✓ 06-04	Accel./Decel. Time Selection of Stall Prevention at constant speed	0: by current accel/decel time 1: by the 1st accel/decel time 2: by the 2nd accel/decel time 3: by the 3rd accel/decel time 4: by the 4th accel/decel time 5: by auto accel/decel time	0	<input type="radio"/>	<input type="radio"/>	<input type="radio"/>			
✓ 06-05	Over-torque Detection Selection (OT1)	0: disable 1: over-torque detection during constant speed operation, continue to operate after detection 2: over-torque detection during constant speed operation, stop operation after detection 3: over-torque detection during operation, continue to operate after detection 4: over-torque detection during operation, stop operation after detection	0	<input type="radio"/>	<input type="radio"/>	<input type="radio"/>	<input type="radio"/>	<input type="radio"/>	<input type="radio"/>
✓ 06-06	Over-torque Detection Level (OT1)	10~250%	150	<input type="radio"/>	<input type="radio"/>	<input type="radio"/>	<input type="radio"/>	<input type="radio"/>	<input type="radio"/>
✓ 06-07	Over-torque Detection Time (OT1)	0.0~60.0sec.	0.1	<input type="radio"/>	<input type="radio"/>	<input type="radio"/>	<input type="radio"/>	<input type="radio"/>	<input type="radio"/>
✓ 06-08	Over-torque Detection Selection (OT2)	0: disable 1: over-torque detection during constant speed operation, continue to operate after detection 2: over-torque detection during constant speed operation, stop operation after detection 3: over-torque detection during operation, continue to operate after detection 4: over-torque detection during operation, stop operation after detection	0	<input type="radio"/>	<input type="radio"/>	<input type="radio"/>	<input type="radio"/>	<input type="radio"/>	<input type="radio"/>
✓ 06-09	Over-torque Detection Level (OT2)	10~250%	150	<input type="radio"/>	<input type="radio"/>	<input type="radio"/>	<input type="radio"/>	<input type="radio"/>	<input type="radio"/>
✓ 06-10	Over-torque Detection Time (OT2)	0.0~60.0sec.	0.1	<input type="radio"/>	<input type="radio"/>	<input type="radio"/>	<input type="radio"/>	<input type="radio"/>	<input type="radio"/>
✓ 06-11	Current Limit	0~250%	200				<input type="radio"/>	<input type="radio"/>	<input type="radio"/>
✓ 06-12	Electronic Thermal Relay Selection	0: Inverter motor 1: Standard motor 2: Disable	2	<input type="radio"/>	<input type="radio"/>	<input type="radio"/>	<input type="radio"/>	<input type="radio"/>	<input type="radio"/>
✓ 06-13	Electronic Thermal Characteristic	30.0~600.0sec.	60.0	<input type="radio"/>	<input type="radio"/>	<input type="radio"/>	<input type="radio"/>	<input type="radio"/>	<input type="radio"/>
✓ 06-14	Heat Sink Over-heat (OH) Warning	0.0~110.0°C	85.0	<input type="radio"/>	<input type="radio"/>	<input type="radio"/>	<input type="radio"/>	<input type="radio"/>	<input type="radio"/>
✓ 06-15	Stall Prevention Limit Level	0~100% (Refer to Pr06-02, Pr06-03)	50	<input type="radio"/>	<input type="radio"/>	<input type="radio"/>			
06-16	Present Fault Record	0: No fault	0	<input type="radio"/>	<input type="radio"/>	<input type="radio"/>	<input type="radio"/>	<input type="radio"/>	<input type="radio"/>

06-17	Second Most Recent Fault Record	1: Over-current during acceleration (ocA)	0	<input type="radio"/>	<input type="radio"/>	<input type="radio"/>	<input type="radio"/>	<input type="radio"/>	<input type="radio"/>
06-18	Third Most Recent Fault Record	2: Over-current during deceleration (ocd)	0	<input type="radio"/>	<input type="radio"/>	<input type="radio"/>	<input type="radio"/>	<input type="radio"/>	<input type="radio"/>
06-19	Fourth Most Recent Fault Record	3: Over-current during constant speed (ocn)	0	<input type="radio"/>	<input type="radio"/>	<input type="radio"/>	<input type="radio"/>	<input type="radio"/>	<input type="radio"/>
06-20	Fifth Most Recent Fault Record	4: Ground fault (GFF)	0	<input type="radio"/>	<input type="radio"/>	<input type="radio"/>	<input type="radio"/>	<input type="radio"/>	<input type="radio"/>
06-21	Sixth Most Recent Fault Record	5: IGBT short-circuit (occ) 6: Over-current at stop (ocS) 7: Over-voltage during acceleration (ovA) 8: Over-voltage during deceleration (ovd) 9: Over-voltage during constant speed (ovn) 10: Over-voltage at stop (ovS) 11: Low-voltage during acceleration (LvA) 12: Low-voltage during deceleration (Lvd) 13: Low-voltage during constant speed (Lvn) 14: Low-voltage at stop (LvS) 15: Phase loss (PHL) 16: IGBT heat sink over-heat (oH1) 17: Heat sink over-heat (oH2)(for 40HP above) 18: TH1 open loop error (tH1o) 19: TH2 open loop error (tH2o) 20: Fan error signal output	0	<input type="radio"/>	<input type="radio"/>	<input type="radio"/>	<input type="radio"/>	<input type="radio"/>	<input type="radio"/>
		21: over-load (150% 1Min) 22: Motor over-load (EoL1) 23: Reserved 24: Motor PTC overheat (oH3) 25: Reserved 26: over-torque 1 (ot1) 27: over-torque 1 (ot2) 28: Reserved 29: Reserved 30: Memory write-in error (cF1) 31: Memory read-out error (cF2) 32: Isum current detection error (cd0) 33: U-phase current detection error (cd1) 34: V-phase current detection error (cd2) 35: W-phase current detection error (cd3) 36: Clamp current detection error (Hd0) 37: Over-current detection error (Hd1) 38: Over-voltage detection error (Hd2) 39: Ground current detection error (Hd3) 40: Auto tuning error (AuE) 41: PID feedback loss (AFE) 42: PG feedback error (PGF1) 43: PG feedback loss (PGF2) 44: PG feedback stall (PGF3) 45: PG slip error (PGF4) 46: PG ref input error (PGr1) 47: PG ref loss (PGr2) 48: Analog current input error (ACE) 49: External fault input (EF) 50: Emergency stop (EF1) 51: Reserved 52: Password error (PcodE) 53: Reserved 54: Communication error (cE1) 55: Communication error (cE2) 56L Communication error (cE3) 57: Communication error (cE4) 58: Communication Time-out (cE10) 59: PU time-out (cP10) 60: Brake chopper error (bF)							

		61-62: Reserved 63: Safety loop error (Sry) 64: Mechanical brake error (MBF) 65: PGF5 hardware error 66: Magnetic contactor error 67: Phase loss of drive output (MPHL) 68: CAN Bus disconnected 69: Safety Torque Off (STO) 70: Channel 1(STO1~SCM1) abnormal safety circuit 71: Channel 2(STO2~SCM2) abnormal safety circuit 72: Abnormal internal circuit									
✓	06-22	Fault Output Option 1	0~65535 (refer to bit table for fault code)	0		○	○	○	○	○	○
✓	06-23	Fault Output Option 2	0~65535 (refer to bit table for fault code)	0		○	○	○	○	○	○
✓	06-24	Fault Output Option 3	0~65535 (refer to bit table for fault code)	0		○	○	○	○	○	○
✓	06-25	Fault Output Option 4	0~65535 (refer to bit table for fault code)	0		○	○	○	○	○	○
✓	06-26	PTC (Positive Temperature Coefficient) Detection Selection	0: Warn and keep operation 1: Warn and ramp to stop	0		○	○	○	○	○	○
✓	06-27	PTC Level	0.0~100.0%	50.0		○	○	○	○	○	○
✓	06-28	Filter Time for PTC Detection	0.00~10.00sec.	0.20		○	○	○	○	○	○
	06-29	Voltage of Emergency Power	48.0~375.0Vdc 96.0~750.0Vdc	48.0 96.0		○	○	○	○	○	○
✓	06-30	Setting Method of Fault Output	0: By settings of Pr.06-22~06-25 1: By the binary setting	0		○	○	○	○	○	○
	06-31	Phase Loss Detection of Drive Output at Start up(MPHL)	0: Disable 1: Enable	0		○	○	○	○	○	○
	06-32	Accumulative Drive Power-on Time at the First Fault (min.)	00~1439	00		○	○	○	○	○	
	06-33	Accumulative Drive Power-on Time at the First Fault (day)	00-65535	00		○	○	○	○	○	
	06-34	Accumulative Drive Power-on Time at the Second Fault (min.)	00~1439	00		○	○	○	○	○	
	06-35	Accumulative Drive Power-on Time at the Second Fault (day)	00-65535	00		○	○	○	○	○	
	06-36	Accumulative Drive Power-on Time at the Third Fault (min.)	00~1439	00		○	○	○	○	○	
	06-37	Accumulative Drive Power-on Time at the Third Fault (day)	00-65535	00		○	○	○	○	○	
	06-38	Accumulative Drive Power-on Time at the Fourth Fault (min.)	00~1439	00		○	○	○	○	○	
	06-39	Accumulative Drive Power-on Time at the Fourth Fault (day)	00-65535	00		○	○	○	○	○	
	06-40	Accumulative Drive Power-on Time at the Fifth Fault (min.)	00~1439	00		○	○	○	○	○	
	06-41	Accumulative Drive Power-on Time at the Fifth Fault (day)	00-65535	00		○	○	○	○	○	
	06-42	Accumulative Drive Power-on Time at the Sixth Fault (min.)	00~1439	00		○	○	○	○	○	
	06-43	Accumulative Drive Power-on Time at the	00-65535	00		○	○	○	○	○	

Sixth Fault (day)										
↘	06-44	Operation Speed of Emergency Power Mode	0.00~400.00Hz	Read Only	○	○	○	○	○	○
↘	06-45	Low-voltage Protection	Bit0 = 0: Display Lv fault and coast to stop Bit0 = 1: Display Lv warn and coast to stop Bit1 = 0: Fan lock, fault and coast to stop Bit1 = 1: Fan lock, warn and coast to stop	0	○	○	○	○	○	○
↘	06-46	Operation Direction for Emergency Power ON	0: Run by following the current command 1: Run by following the direction of power generating mode. 2: After determining the direction of power generating, the host computer sends the operating direction command. (When at STOP mode determine the direction of power generating mode (MO =32) but do not retain the direction of the power generating.) 3. After determining the direction of power generating, the host computer send the operating direction command. (When at STOP mode, determine the direction of power generating mode (MO =32) and retain the direction of the power generating.)	1	○	○	○	○	○	○
↘	06-47	Power Generation Direction Searching Time	0.0 ~ 5.0sec.	1.0	○	○	○	○	○	○
	06-48	Power Capacity of Emergency Power	0.0 ~ 100.0 kVA	0.0	○	○	○	○	○	○
	06-49	STO Latch Selection	0: STO Latch 1: STO No Latch	0	○	○	○	○	○	○

07 Speical Parameters

Pr.	Explanation	Setting Range	Factory Setting	VF	VFP	SVC	FOCP	TQCP	FOCP
✓ 07-00	Brake Chopper Level	230V serie: 350.0~450.0Vdc 460V serie: 700.0~900.0Vdc	380.0 760.0	<input type="radio"/>	<input type="radio"/>	<input type="radio"/>	<input type="radio"/>	<input type="radio"/>	<input type="radio"/>
07-01	Reserved								
✓ 07-02	Brake Chopper Level	0~100%	0	<input type="radio"/>	<input type="radio"/>	<input type="radio"/>			
✓ 07-03	Brake Chopper Level	0.0~60.0sec.	0.0	<input type="radio"/>	<input type="radio"/>	<input type="radio"/>	<input type="radio"/>		<input type="radio"/>
✓ 07-04	Brake Chopper Level	0.0~60.0sec.	0.0	<input type="radio"/>	<input type="radio"/>	<input type="radio"/>	<input type="radio"/>		<input type="radio"/>
✓ 07-05	Brake Chopper Level	0.00~400.00Hz	0.00	<input type="radio"/>	<input type="radio"/>	<input type="radio"/>	<input type="radio"/>		
✓ 07-06	Brake Chopper Level	1~500	50	<input type="radio"/>	<input type="radio"/>	<input type="radio"/>			
✓ 07-07	Brake Chopper Level	0.00~600.00sec.	0.00	<input type="radio"/>	<input type="radio"/>	<input type="radio"/>	<input type="radio"/>		<input type="radio"/>
✓ 07-08	Brake Chopper Level	0.00~400.00Hz	0.00	<input type="radio"/>	<input type="radio"/>	<input type="radio"/>	<input type="radio"/>		<input type="radio"/>
✓ 07-09	Brake Chopper Level	0.00~600.00sec.	0.00	<input type="radio"/>	<input type="radio"/>	<input type="radio"/>	<input type="radio"/>		<input type="radio"/>
✓ 07-10	Brake Chopper Level	0.00~400.00Hz	0.00	<input type="radio"/>	<input type="radio"/>	<input type="radio"/>	<input type="radio"/>		<input type="radio"/>
✓ 07-11	Cooling Fan Control	0: Coolign fan always ON 1: 1 minute after AC motor drive stops, cooling fan will be OFF 2: AC motor drive runs and cooling fan ON, AC motor drive stops and cooling fan OFF 3: Cooling fan ON to run when preliminary heat sink temperature attained 4: Cooling always OFF	2	<input type="radio"/>	<input type="radio"/>	<input type="radio"/>	<input type="radio"/>	<input type="radio"/>	<input type="radio"/>
✓ 07-12	Torque command	-100.0~100.0% (Pr07-14 setting =100%)	0.0					<input type="radio"/>	
✓ 07-13	Source of Torque Command	0: Digital keypad (KPC-CC01) 1: RS485 serial communication (RJ-11) 2: Analog signal (Pr.03-00)	2					<input type="radio"/>	
✓ 07-14	Maximum Torque Command	0~300%	100	<input type="radio"/>	<input type="radio"/>	<input type="radio"/>	<input type="radio"/>	<input type="radio"/>	<input type="radio"/>
✓ 07-15	Filter Time of Torque Command	0.000~1.000sec.	0.000					<input type="radio"/>	
07-16	Speed Limit Selection	0: By Pr.07-17 and Pr.07-18 1: Frequency command source (Pr.00-14)	0					<input type="radio"/>	
✓ 07-17	Torque Mode +Speed Limit	0~120%	10					<input type="radio"/>	
✓ 07-18	Torque Mode-Speed Limit	0~120%	10					<input type="radio"/>	
✓ 07-19	Source of Torque Offset	0: Disable 1: Analog input (Pr.03-00) 2: Torque offset setting (Pr.07-20) 3: Control by external terminal (by Pr.07-21 to Pr.07-23)	0			<input type="radio"/>	<input type="radio"/>	<input type="radio"/>	<input type="radio"/>
✓ 07-20	Torque Offset Setting	0.0~100.0%	0.0			<input type="radio"/>	<input type="radio"/>	<input type="radio"/>	<input type="radio"/>
✓ 07-21	High Torque Offset	0.0~100.0%	30.0			<input type="radio"/>	<input type="radio"/>	<input type="radio"/>	<input type="radio"/>
✓ 07-22	Middle Torque Offset	0.0~100.0%	20.0			<input type="radio"/>	<input type="radio"/>	<input type="radio"/>	<input type="radio"/>
✓ 07-23	Low Torque Offset	0.0~100.0%	10.0			<input type="radio"/>	<input type="radio"/>	<input type="radio"/>	<input type="radio"/>
✓ 07-24	Forward Motor Torque Limit	0~300%	200				<input type="radio"/>	<input type="radio"/>	<input type="radio"/>
✓ 07-25	Forward Regenerative Torque Limit	0~300%	200				<input type="radio"/>	<input type="radio"/>	<input type="radio"/>

↘	07-26	Reverse Motor Torque Limit	0~300%	200					○	○	○
↘	07-27	Reverse Regenerative Torque Limit	0~300%	200					○	○	○
↘	07-28	Emergency Stop (EF) & Forced Stop Selection	0: Coast to stop 1: By deceleration Time 1 2: By deceleration Time 2 3: By deceleration Time 3 4: By deceleration Time 4 5: By Pr.01-31	0	○	○	○	○	○	○	○
↘	07-29	Time for Decreasing Torque at Stop	0.000~1.000sec.	0.000					○	○	○

08 PM Parameters

Pr.	Explanation	Setting Range	Factory Setting	VF	VFP	SVC	FOCPG	TQCPG	FOCPM
08-00	Motor Auto Tuning	0: No function 1: Only for the unloaded motor, auto measure the angle between magnetic pole and PG origin (08-09) 2: For PM parameters 3: Auto measure the angle between magnetic pole and PG origin (08-09)	0						<input type="radio"/>
08-01	Full-load Current of Motor	(40~120%) *00-01 Amps	###						<input type="radio"/>
08-02	Rated power of Motor	0.00~655.35kW	###						<input type="radio"/>
08-03	Rated speed of Motor (rpm)	0~65535	1710						<input type="radio"/>
08-04	Number of Motor Poles	2~96	4						<input type="radio"/>
08-05	Rs of Motor	0.000~65.535Ω	0.000						<input type="radio"/>
08-06	Ld of Motor	0.0~6553.5mH	0.0						<input type="radio"/>
08-07	Lq of Motor	0.0~6553.5mH	0.0						<input type="radio"/>
08-08	Back Electromotive Force	0.0~6553.5Vrms	0.0						<input type="radio"/>
08-09	Angle between Magnetic Pole and PG Origin	0.0~360.0°	360.0						<input type="radio"/>
08-10	Magnetic Pole Re-orientation	0: Disable 1: Enable	0						<input type="radio"/>

09 Communication Parameters

Pr.	Explanation	Setting Range	Factory Setting	VF	VFPG	SVC	FOCPG	TQCPG	FOCPM
✓ 09-00	Communication Address	1~254	1						
✓ 09-01	Transmission Speed	4.8~115.2Kbps	9.6	<input type="radio"/>	<input type="radio"/>	<input type="radio"/>	<input type="radio"/>	<input type="radio"/>	<input type="radio"/>
✓ 09-02	Transmission Fault Treatment	0: Warn and keep operation 1: Warn and ramp to stop 2: Reserved 3: No action and no display	3	<input type="radio"/>	<input type="radio"/>	<input type="radio"/>	<input type="radio"/>	<input type="radio"/>	<input type="radio"/>
✓ 09-03	Time-out Detection	0.0~100.0sec.	0.0	<input type="radio"/>	<input type="radio"/>	<input type="radio"/>	<input type="radio"/>	<input type="radio"/>	<input type="radio"/>
✓ 09-04	Communication Protocol	0: 7N1 (ASCII) 1: 7N2 (ASCII) 2: 7E1 (ASCII) 3: 7O1 (ASCII) 4: 7E2 (ASCII) 5: 7O2 (ASCII) 6: 8N1 (ASCII) 7: 8N2 (ASCII) 8: 8E1 (ASCII) 9: 8O1 (ASCII) 10: 8E2 (ASCII) 11: 8O2 (ASCII) 12: 8N1 (RTU) 13: 8N2 (RTU) 14: 8E1 (RTU) 15: 8O1 (RTU) 16: 8E2 (RTU) 17: 8O2 (RTU)	13	<input type="radio"/>	<input type="radio"/>	<input type="radio"/>	<input type="radio"/>	<input type="radio"/>	<input type="radio"/>
✓ 09-05	Response Delay Time	0.0~200.0ms	2.0	<input type="radio"/>	<input type="radio"/>	<input type="radio"/>	<input type="radio"/>	<input type="radio"/>	<input type="radio"/>

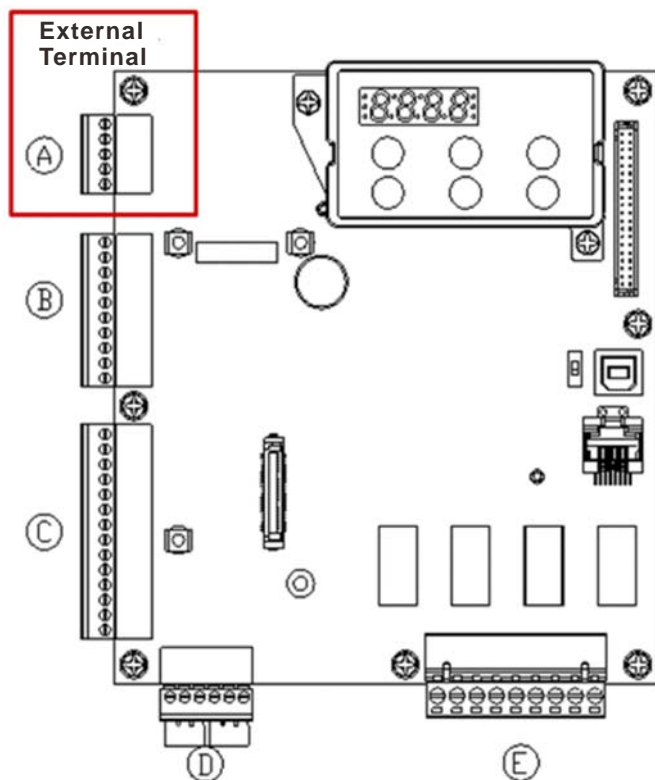

10 Speed Feedback Control Parameters

Pr.	Explanation	Setting Range	Factory Setting	VF	VFP	SVC	FOCPG	TQCPG	FOCPM
10-00	Selection of Encoder	0: No function 1: ABZ 2: ABZ+Hall 3: SIN/COS + Sinusoidal 4: SIN/COS + Endat 5: SIN/COS 6: SIN/COS + Hiperface	0		<input type="radio"/>		<input type="radio"/>	<input type="radio"/>	<input type="radio"/>
10-01	Encoder Pulse	1~25000	600		<input type="radio"/>		<input type="radio"/>	<input type="radio"/>	<input type="radio"/>
10-02	Encoder Input Type Setting	0: Disable 1: Phase A leads in a forward run command and phase B leads in a reverse run command 2: Phase B leads in a forward run command and phase A leads in a reverse run command 3: Phase A is a pulse input and phase B is a direction input. (low input=reverse direction, high input=forward direction) 4: Phase A is a pulse input and phase B is a direction input. (low input=forward direction, high input=reverse direction) 5: Single-phase input	0		<input type="radio"/>		<input type="radio"/>	<input type="radio"/>	<input type="radio"/>
✓ 10-03	Encoder Feedback Fault Treatment (PGF1, PGF2)	0: Fault and keep operation 1: Fault and ramp to stop 2: Fault and stop operation	2		<input type="radio"/>		<input type="radio"/>	<input type="radio"/>	<input type="radio"/>
✓ 10-04	Detection Time for Encoder Feedback Fault	0.0~10.0sec.	1.0		<input type="radio"/>		<input type="radio"/>	<input type="radio"/>	<input type="radio"/>
✓ 10-05	Encoder Stall Level (PGF3)	0~120% (0: Disable)	115		<input type="radio"/>	<input type="radio"/>	<input type="radio"/>		<input type="radio"/>
✓ 10-06	Encoder Stall Detection Time	0.0~2.0sec.	0.1		<input type="radio"/>	<input type="radio"/>	<input type="radio"/>		<input type="radio"/>
✓ 10-07	Encoder Slip Range (PGF4)	0~50% (0: Disable)	50		<input type="radio"/>	<input type="radio"/>	<input type="radio"/>		<input type="radio"/>
✓ 10-08	Encoder Slip Detection Time	0.0~10.0sec.	0.5		<input type="radio"/>	<input type="radio"/>	<input type="radio"/>		<input type="radio"/>
✓ 10-09	Encoder Stall and Slip Error Treatment	0: Fault and keep operation 1: Fault and ramp to stop 2: Fault and coast to stop	2		<input type="radio"/>	<input type="radio"/>	<input type="radio"/>		<input type="radio"/>
10-10	Mode Selection for UVW Input	0: Z signal is at the falling edge of U-phase 1: Z signal is at the rising edge of U-phase	0		<input type="radio"/>		<input type="radio"/>	<input type="radio"/>	<input type="radio"/>
✓ 10-11	ASR (Auto Speed Regulation) Control (P) of Zero Speed	0.0~500.0%	100.0		<input type="radio"/>	<input type="radio"/>	<input type="radio"/>	<input type="radio"/>	<input type="radio"/>
✓ 10-12	ASR (Auto Speed Regulation) Control (I) of Zero Speed	0.000~10.000sec.	0.100		<input type="radio"/>	<input type="radio"/>	<input type="radio"/>	<input type="radio"/>	<input type="radio"/>
✓ 10-13	ASR (Auto Speed Regulation) Control (P) 1	0.0~500.0%	100.0		<input type="radio"/>	<input type="radio"/>	<input type="radio"/>	<input type="radio"/>	<input type="radio"/>
✓ 10-14	ASR (Auto Speed Regulation) Control (I) 1	0.000~10.000sec.	0.100		<input type="radio"/>	<input type="radio"/>	<input type="radio"/>	<input type="radio"/>	<input type="radio"/>
✓ 10-15	ASR (Auto Speed Regulation) Control (P) 2	0.0~500.0%	100.0		<input type="radio"/>	<input type="radio"/>	<input type="radio"/>	<input type="radio"/>	<input type="radio"/>
✓ 10-16	ASR (Auto Speed	0.000~10.000sec.	0.100		<input type="radio"/>	<input type="radio"/>	<input type="radio"/>	<input type="radio"/>	<input type="radio"/>

		Regulation) Control (I) 2							
✓	10-17	ASR 1/ASR2 Switch Frequency	0.00~400.00Hz (0: Disable)	7.00	○	○	○	○	○
✓	10-18	ASR Primary Low Pass Filter Gain	0.000~0.350sec.	0.008	○	○	○	○	○
✓	10-19	Zero Speed Gain (P)	0~655.00%	80.00					○
✓	10-20	Zero Speed/ASR1 Width Adjustment	0.00~400.00Hz	5.00		○		○	○
✓	10-21	ASR1/ASR2 Width Adjustment	0.00~400.00Hz	5.00		○		○	○
✓	10-22	Zero speed Position Holding Time	0.000~65.535s	0.250					○
✓	10-23	Filter Time at Zero Speed	0.000~65.535s	0.004					○
✓	10-24	Time for Executing Zero Speed	0: after the brake release set in Pr.02-29 1: after the brake signal input (Pr.02-01~02-08 is set to 42)	0					○
✓	10-25	Elevator Leveling (Zero Speed Gain P)	0~1000.0%	100.0	○	○	○	○	○
✓	10-26	Elevator Leveling (Zero Speed Integral I)	0~10.000sec.	0.100	○	○	○	○	○
✓	10-27	Elevator Starts (Zero Speed Gain P)	0~1000.0%	100.0	○	○	○	○	○
✓	10-28	Elevator Starts (Zero Speed Integral I)	0~10.000sec.	0.100	○	○	○	○	○
✓	10-29	Setting of PG card frequency division output	0~32	0		○		○	○
✓	10-30	Type of PG card frequency division output	0x00~0x02	0		○		○	○

11 Advanced Parameters

Pr.	Explanation	Setting Range	Factory Setting	VF	VFP	SVC	FOCPG	TQCPG	FOCPM
11-00	System Control	Bit 0=0: no function Bit 0=1: ASR Auto tuning, PDFF enable Bit 7=0: no function Bit 7=1: When position control is enabled, it doesn't need to set Pr.07-02 (DC Brake Current Level) Bit 15=0: when power is applied, it will detect the position of magnetic pole again Bit 15=1: when power is applied, it will start from the magnetic pole position of previous power failure	0				<input type="radio"/>		<input type="radio"/>
✓ 11-01	Elevator Speed	0.10~4.00 m/s	1				<input type="radio"/>		<input type="radio"/>
✓ 11-02	Sheave Diameter	100~2000mm	400				<input type="radio"/>		<input type="radio"/>
✓ 11-03	Mechanical Gear Ratio	1~100	1				<input type="radio"/>		<input type="radio"/>
✓ 11-04	Suspension Ratio	0= 1:1 1= 2:1	1				<input type="radio"/>		<input type="radio"/>
✓ 11-05	Inertial Ratio	1~300%	40				<input type="radio"/>		<input type="radio"/>
✓ 11-06	Zero-speed Bandwidth	0~40Hz	10				<input type="radio"/>		<input type="radio"/>
✓ 11-07	Low-speed Bandwidth	0~40Hz	10				<input type="radio"/>		<input type="radio"/>
✓ 11-08	High-speed Bandwidth	0~40Hz	10				<input type="radio"/>		<input type="radio"/>
✓ 11-09	PDFF Gain Value	0~200%	30				<input type="radio"/>		<input type="radio"/>
✓ 11-10	Gain for Speed Feed Forward	0~500	0				<input type="radio"/>		<input type="radio"/>
✓ 11-11	Notch Filter Depth	0~20db	0				<input type="radio"/>		<input type="radio"/>
✓ 11-12	Notch Filter Frequency	0.00~200.00Hz	0.00				<input type="radio"/>		<input type="radio"/>
✓ 11-13	Low-pass Filter Time of Keypad Display	0.001~65.535s	0.500	<input type="radio"/>	<input type="radio"/>	<input type="radio"/>	<input type="radio"/>	<input type="radio"/>	<input type="radio"/>
✓ 11-14	Motor Current at Accel.	50~200%	150						<input type="radio"/>
✓ 11-15	Elevator Acceleration	0.20~2.00m/s ²	0.75						<input type="radio"/>
11-16	Reserved	0X0000~0XFFFF	0	<input type="radio"/>	<input type="radio"/>	<input type="radio"/>	<input type="radio"/>	<input type="radio"/>	<input type="radio"/>
11--17	Reserved	Read Only	###	<input type="radio"/>	<input type="radio"/>	<input type="radio"/>	<input type="radio"/>	<input type="radio"/>	<input type="radio"/>
11-18	Reserved	0X0000~0XFFFF	###	<input type="radio"/>	<input type="radio"/>	<input type="radio"/>	<input type="radio"/>	<input type="radio"/>	<input type="radio"/>

12 User Defined Parameters

User-defined Parameters with range from Group 00 to Group 11

Pr.	Explanation (Default Function)	Address	Factory setting	VF	VFP	SVC	FOCPG	TQCPG	FOCPM
				<input type="checkbox"/>	<input type="checkbox"/>	<input type="checkbox"/>	<input type="checkbox"/>	<input type="checkbox"/>	<input type="checkbox"/>
✓ 12-00	Present Fault Record	0610	Read Only	<input type="checkbox"/>	<input type="checkbox"/>	<input type="checkbox"/>	<input type="checkbox"/>	<input type="checkbox"/>	<input type="checkbox"/>
✓ 12-01	Present Fault Time of Motor Operation (min.)	0620	Read Only	<input type="checkbox"/>	<input type="checkbox"/>	<input type="checkbox"/>	<input type="checkbox"/>	<input type="checkbox"/>	<input type="checkbox"/>
✓ 12-02	Present Fault Time of Motor Operation (day)	0621	Read Only	<input type="checkbox"/>	<input type="checkbox"/>	<input type="checkbox"/>	<input type="checkbox"/>	<input type="checkbox"/>	<input type="checkbox"/>
✓ 12-03	Frequency Command at Present Fault	2120	Read Only	<input type="checkbox"/>	<input type="checkbox"/>	<input type="checkbox"/>	<input type="checkbox"/>	<input type="checkbox"/>	<input type="checkbox"/>
✓ 12-04	Output Frequency at Preset Fault	2121	Read Only	<input type="checkbox"/>	<input type="checkbox"/>	<input type="checkbox"/>	<input type="checkbox"/>	<input type="checkbox"/>	<input type="checkbox"/>
✓ 12-05	Output Current at Present Fault	2122	Read Only	<input type="checkbox"/>	<input type="checkbox"/>	<input type="checkbox"/>	<input type="checkbox"/>	<input type="checkbox"/>	<input type="checkbox"/>
✓ 12-06	Motor Frequency at Present Fault	2123	Read Only	<input type="checkbox"/>	<input type="checkbox"/>	<input type="checkbox"/>	<input type="checkbox"/>	<input type="checkbox"/>	<input type="checkbox"/>
✓ 12-07	Output Voltage at Present Fault	2124	Read Only	<input type="checkbox"/>	<input type="checkbox"/>	<input type="checkbox"/>	<input type="checkbox"/>	<input type="checkbox"/>	<input type="checkbox"/>
✓ 12-08	DC-Bus Voltage at Present Fault	2125	Read Only	<input type="checkbox"/>	<input type="checkbox"/>	<input type="checkbox"/>	<input type="checkbox"/>	<input type="checkbox"/>	<input type="checkbox"/>
✓ 12-09	Output Power at Present Fault	2126	Read Only	<input type="checkbox"/>	<input type="checkbox"/>	<input type="checkbox"/>	<input type="checkbox"/>	<input type="checkbox"/>	<input type="checkbox"/>
✓ 12-10	Output Torque at Present Fault	2127	Read Only	<input type="checkbox"/>	<input type="checkbox"/>	<input type="checkbox"/>	<input type="checkbox"/>	<input type="checkbox"/>	<input type="checkbox"/>
✓ 12-11	IGBT Temperature of Power Module at Present Fault	2128	Read Only	<input type="checkbox"/>	<input type="checkbox"/>	<input type="checkbox"/>	<input type="checkbox"/>	<input type="checkbox"/>	<input type="checkbox"/>
✓ 12-12	Multi-function Terminal Input Status at Present Fault	2129	Read Only	<input type="checkbox"/>	<input type="checkbox"/>	<input type="checkbox"/>	<input type="checkbox"/>	<input type="checkbox"/>	<input type="checkbox"/>
✓ 12-13	Multi-function Terminal Output Status at Present Fault	212A	Read Only	<input type="checkbox"/>	<input type="checkbox"/>	<input type="checkbox"/>	<input type="checkbox"/>	<input type="checkbox"/>	<input type="checkbox"/>
✓ 12-14	Drive Status at Present Fault	212B	Read Only	<input type="checkbox"/>	<input type="checkbox"/>	<input type="checkbox"/>	<input type="checkbox"/>	<input type="checkbox"/>	<input type="checkbox"/>
✓ 12-15	Second Most Recent Fault Record	0611	Read Only	<input type="checkbox"/>	<input type="checkbox"/>	<input type="checkbox"/>	<input type="checkbox"/>	<input type="checkbox"/>	<input type="checkbox"/>
✓ 12-16	Second Most Recent Fault Time of Motor Operation (min.)	0622	Read Only	<input type="checkbox"/>	<input type="checkbox"/>	<input type="checkbox"/>	<input type="checkbox"/>	<input type="checkbox"/>	<input type="checkbox"/>
✓ 12-17	Second Most Recent Fault Time of Motor Operation (day)	0623	Read Only	<input type="checkbox"/>	<input type="checkbox"/>	<input type="checkbox"/>	<input type="checkbox"/>	<input type="checkbox"/>	<input type="checkbox"/>
✓ 12-18	Third Most Recent Fault Record	0612	Read Only	<input type="checkbox"/>	<input type="checkbox"/>	<input type="checkbox"/>	<input type="checkbox"/>	<input type="checkbox"/>	<input type="checkbox"/>
✓ 12-19	Third Most Recent Fault Time of Motor Operation (min.)	0624	Read Only	<input type="checkbox"/>	<input type="checkbox"/>	<input type="checkbox"/>	<input type="checkbox"/>	<input type="checkbox"/>	<input type="checkbox"/>
✓ 12-20	Third Most Recent Fault Time of Motor Operation (day)	0625	Read Only	<input type="checkbox"/>	<input type="checkbox"/>	<input type="checkbox"/>	<input type="checkbox"/>	<input type="checkbox"/>	<input type="checkbox"/>
✓ 12-21	Fourth Most Recent Fault Record	0613	Read Only	<input type="checkbox"/>	<input type="checkbox"/>	<input type="checkbox"/>	<input type="checkbox"/>	<input type="checkbox"/>	<input type="checkbox"/>
✓ 12-22	Fourth Most Recent Fault Time of Motor Operation (min.)	0626	Read Only	<input type="checkbox"/>	<input type="checkbox"/>	<input type="checkbox"/>	<input type="checkbox"/>	<input type="checkbox"/>	<input type="checkbox"/>
✓ 12-23	Fourth Most Recent Fault Time of Motor Operation (day)	0627	Read Only	<input type="checkbox"/>	<input type="checkbox"/>	<input type="checkbox"/>	<input type="checkbox"/>	<input type="checkbox"/>	<input type="checkbox"/>
✓ 12-24	Fifth Most Recent Fault Record	0614	Read Only	<input type="checkbox"/>	<input type="checkbox"/>	<input type="checkbox"/>	<input type="checkbox"/>	<input type="checkbox"/>	<input type="checkbox"/>
✓ 12-25	Fifth Most Recent Fault Time of Motor Operation (min.)	0628	Read Only	<input type="checkbox"/>	<input type="checkbox"/>	<input type="checkbox"/>	<input type="checkbox"/>	<input type="checkbox"/>	<input type="checkbox"/>
✓ 12-26	Fifth Most Recent Fault Time of Motor Operation (day)	0629	Read Only	<input type="checkbox"/>	<input type="checkbox"/>	<input type="checkbox"/>	<input type="checkbox"/>	<input type="checkbox"/>	<input type="checkbox"/>
✓ 12-27	Sixth Most Recent Fault Record	0615	Read Only	<input type="checkbox"/>	<input type="checkbox"/>	<input type="checkbox"/>	<input type="checkbox"/>	<input type="checkbox"/>	<input type="checkbox"/>
✓ 12-28	Sixth Most Recent Fault Time of Motor Operation (min.)	062A	Read Only	<input type="checkbox"/>	<input type="checkbox"/>	<input type="checkbox"/>	<input type="checkbox"/>	<input type="checkbox"/>	<input type="checkbox"/>
✓ 12-29	Sixth Most Recent Fault Time of Motor Operation (day)	062B	Read Only	<input type="checkbox"/>	<input type="checkbox"/>	<input type="checkbox"/>	<input type="checkbox"/>	<input type="checkbox"/>	<input type="checkbox"/>
✓ 12-30	No factory setting								
✓ 12-31	No factory setting								

13 View User-defind Parameters

Pr.	Explanation	Setting Range	Factory Setting	VF	VFPG	SVC	FOCPG	TQCPG	FOCPM
13-00 ~ 13-31	View User-defined Parameters	Pr00-00~ Pr11-17	-	<input type="radio"/>	<input type="radio"/>	<input type="radio"/>	<input type="radio"/>	<input type="radio"/>	<input type="radio"/>

12 Description of Parameter Settings



↗: the parameter can be set during operation

00 Drive Parameters

00-00 Identity Code of the AC Motor Drive

Control Mode **VF VFPG SVC FOC PG TQCPG FOC PM** Factory setting: ##
Settings Read Only

00-01 Rated Current Display of the AC Motor Drive

Control Mode **VF VFPG SVC FOC PG TQCPG FOC PM** Factory setting: ##
Settings Read Only

- 📖 Pr. 00-00 displays the identity code of the AC motor drive. The capacity, rated current, rated voltage and the max. carrier frequency relate to the identity code. Users can use the following table to check how the rated current, rated voltage and max. carrier frequency of the AC motor drive correspond to the identity code.
- 📖 Pr.00-01 displays the rated current of the AC motor drive. By reading this parameter the user can check if the AC motor drive is correct.

230V series										
KW	2.2	4.0	5.5	7.5	11	15	18.5	22	30	37
HP	3	5	7.5	10	15	20	25	30	40	50
Pr00.00	8	10	12	14	16	18	20	22	24	26
Rated Output Current for General Purposes (A)	12.0	20	24	30	45	58	77	87	132	161
Rated Output Current for Elevators (A)	13.7	22.9	27.4	34.3	51.4	66.3	88	99.4	151	184
Max. Carrier Frequency	15kHz							9kHz		

460V series												
KW	4.0	5.5	7.5	11	15	18.5	22	30	37	45	55	175
HP	5	7.5	10	15	20	25	30	40	50	60	75	100
Pr00.00	11	13	15	17	19	21	23	25	27	29	31	33
Rated Output Current for General Purposes (A)	11.5	13	17	23	30	38	45	58	80	100	128	165
Rated Output Current for Elevators (A)	13.1	14.9	19.4	26.3	34.3	43.4	51.4	66.3	92	114	147	189
Max. Carrier Frequency	15kHz						9kHz			6kHz		

00-02 Parameter Reset

Control Mode **VF** **VFP** **SVC** **FOCPG** **TQCPG** **FOCPM** Factory Setting : 0

- Settings
- 0: No Function
 - 1: Read Only
 - 8: Keypad Lock
 - 9: All parameters are reset to factory settings (50Hz)
 - 10: All parameters are reset to factory settings (60Hz)

- 📖 When it is set to 1, all parameters are read only except Pr00-00~Pr00-07 and it can be used with password setting for password protection.
- 📖 To go back to the factory setting, set Pr00-02 = 9 or 10. If it is locked by a password, enter the password to go back to the factory setting. The password will also be erased.
- 📖 When Pr.00-02=08, the keypad is locked and only Pr.00-02 and Pr00-07 can be set. To unlock the keypad, set Pr.00-02=00.

00-03 Start-up Display Selection

Control Mode **VF** **VFP** **SVC** **FOCPG** **TQCPG** **FOCPM** Factory Setting: 0

- Settings
- 0: Display the frequency command value. (LED F)
 - 1: Display the actual output frequency (LED H)
 - 2: DC BUS voltage (V)
 - 3: Display the output current (A)
 - 4: Output voltage (E)
 - 5: User defined (see Pr.00-04)

- 📖 This parameter determines the start-up display page after power is applied to the drive.

00-04 Content of Multi-Function Display

Control Mode **VF** **VFP** **SVC** **FOCPG** **TQCPG** **FOCPM** Factory Setting: 0

- Settings
- 0: Display the output current in A supplied to the motor
 - 1: Reserved
 - 2: Display actual output frequency (H)
 - 3: Display the actual DC BUS voltage in VDC of the AC motor drive
 - 4: Display the output voltage in VAC of terminals U, V, W to the motor.
 - 5: Display the power factor angle in ° of terminals U, V, W to the motor.
 - 6: Display the output power in kW of terminals U, V and W to the motor.
 - 7: Display the actual motor speed in rpm (enabled when using with PG card).
 - 8 : Display the estimated value of torque in % as it relates to current.
 - 9 : Display PG position
 - 10: Display the electrical angle of drive output

- 11: Display the signal of AUI1 analog input terminal in %.
Range -10V~10V corresponds to 0~100%. (1.)
- 12: Reserved
- 13: Display the signal of AUI2 analog input terminal in %.
Range -10V~10V corresponds to 0~100%. (3.)
- 14: Display the temperature of heat sink (°C)
- 15P: Display the temperature of IGBT in °C.
- 16: Display digital input status ON/OFF (i)
- 17: Display digital output status ON/OFF (o)
- 18: Display multi-step speed
- 19: The corresponding CPU pin status of digital input (i.)
- 20: The corresponding CPU pin status of digital output (o.)
- 21~23: Reserved
- 24: Output AC voltage when malfunction (8)
- 25: Output DC voltage when malfunction (8.)
- 26: Motor frequency when malfunction (h)
- 27: Output current when malfunction (4)
- 28: Output frequency when malfunction (h.)
- 29: Frequency command when malfunction
- 30: Output power when malfunction
- 31: Output torque when malfunction
- 32: Input terminal status when malfunction
- 33: Output terminal status when malfunction
- 34: Drive status when malfunction

 This parameter is to display the content on the page U of digital keypad KPC-CC01. It is helpful for getting the AC motor drive's status by this parameter.

Example 01:

Terminal	MI8	MI7	MI6	MI5	MI4	MI3	MI2	MI1	REV	FWD
Status	0	0	1	0	0	0	0	1	1	0

0: OFF, 1: ON

MI1: Pr.02-01 is set to 1 (multi-step speed command 1)

MI8: Pr.02-08 is set to 8 (the 1st, 2nd acceleration/deceleration time selection)

If REV, MI1 and MI8 are ON, the value is 0000 0000 1000 01102 in binary and 0086H in HEX. Meanwhile, if Pr.00-04 is set to "16" or "19", it will display "0086" with LED U is ON on the keypad KPC-CC01. The setting 16 is the status of digital input and the setting 19 is the corresponding CPU pin status of digital input. User can set to 16 to monitor digital input status and then set to 19 to check if the wire is normal.

Example 02:

Terminal	MO8	MO7	MO6	MO5	MO4	MO3	MO2	MO1	R2A	R1A	MRA	RA
Status	0	0	0	0	1	0	0	0	0	1	1	0

RA: Pr.02-11 is set to 9 (Drive ready).

After applying the power to the AC motor drive, if there is no other abnormal status, the contact will be ON. At the meanwhile, if Pr.00-04 is set to 17 or 20, it will display 0001 with LED U is ON on the keypad. The setting 17 is the status of digital output and the setting 20 is the corresponding CPU pin status of digital output. User can set 17 to monitor the digital output status and then set to 20 to check if the wire if normal.

⚡ **00-05** User Defined Coefficient K

Control Mode	VF	VFPG	SVC	FOCPG	TQCPG	FOCPM	Factory Setting:0
Settings	Digit 4: decimal point number (0 to 3)						
	Digit 0-3: 40 to 9999						

- 📖 It is used digital setting method
- Digital 4: decimal point number (0: no decimal point, 1: 1 decimal point and so on.)
- Digit 0-3: 40 to 9999 (the corresponding value for the max. frequency).

Meaning of numerical order

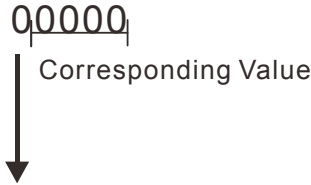

Decimal Point Number

- 📖 For example, if use uses rpm to display the motor speed and the corresponding value to the 4-pole motor 60Hz is 1800. This parameter can be set to 01800 to indicate that the corresponding value for 60Hz is 1800rpm. If the unit is rps, it can be set 10300 to indicate the corresponding value for 60Hz is 30.0 (a decimal point).
- 📖 Only frequency setting can be displayed by the corresponding value.
- 📖 After setting Pr.00-05, it won't display the unit of frequency "Hz" after returning to the main menu.

00-06 Software Version

Control Mode	VF	VFPG	SVC	FOCPG	TQCPG	FOCPM	Factory Setting:###
Settings	Read Only						

⚡ **00-07** Password Input

Control Mode	VF	VFPG	SVC	FOCPG	TQCPG	FOCPM	Factory Setting:0
Settings	1~9998 · 10000~65535						
Display	0~2 (times of wrong password)						

- 📖 The function of this parameter is to input the password that is set in Pr.00-08. Input the correct password here to enable changing parameters. You are limited to a maximum of 3 attempts. After 3 consecutive failed attempts, a fault code "Password Error" will show up to force the user to restart the AC motor drive in order to try again to input the correct password.
- 📖 When forgetting password, you can decode by setting 9999 and press button  twice. Note that all the settings will be set to factory setting.

⚡ **00-08** Password Set

Control Mode	VF	VFPG	SVC	FOCPG	TQCPG	FOCPM	Factory Setting:0
Settings	1~9998 · 10000~65535						
Display	0: No password set or successful input in Pr. 00-07						
	1: Password has been set						

- 📖 To set a password to protect your parameter settings.
If the display shows 0, no password is set or password has been correctly entered in Pr.00-07. All parameters can then be changed, including Pr.00-08.
The first time you can set a password directly. After successful setting of password the display will show 1.

Be sure to record the password for later use.

To cancel the parameter lock, set the parameter to 0 after inputting correct password into Pr. 00-07.

The password consists of min. 2 digits and max. 5 digits.

How to make the password valid again after decoding by Pr.00-07:

Method 1: Re-input original password into Pr.00-08 (Or you can enter a new password if you want to use a changed or new one).

Method 2: After rebooting, password function will be recovered.

Password Decode Flow Chart

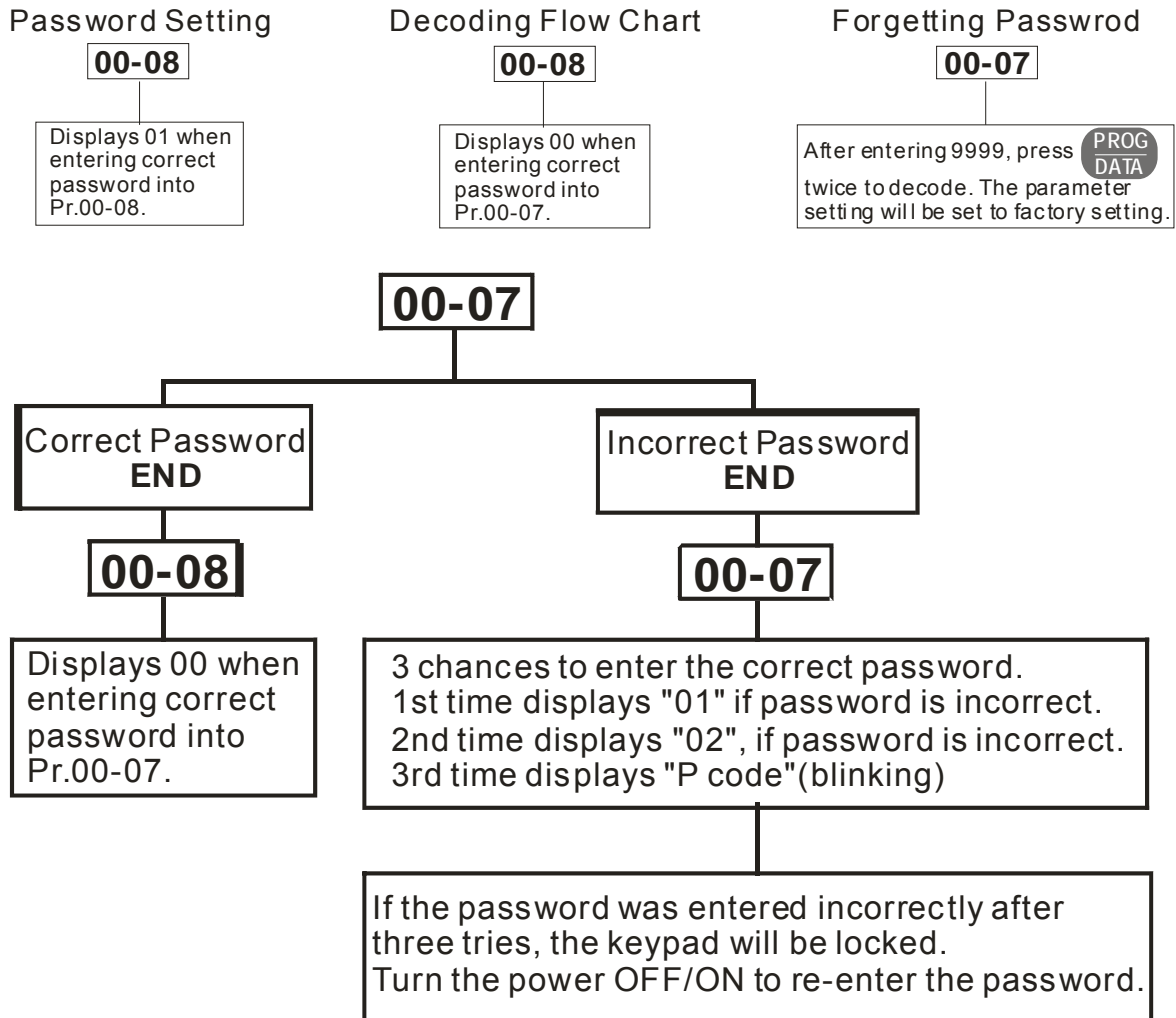

00-09 Control Mode

Control Mode **VF VFBG SVC FOC PG TQCPG FOC PM** Factory Setting:0

- Settings
- 0: V/F control
 - 1: V/F control + Encoder (VFBG)
 - 2: Sensorless Vector Control (SVC)
 - 3 : FOC vector control + Encoder (FOCPG)
 - 4: Torque control + Encoder (TQCPG)
 - 8: FOC Permanent Motor Control+ Encoder (FOCPM)

This parameter determines the control method of the AC motor drive:

Setting 0: user can design V/f ratio by requirement and control multiple motors simultaneously.

Setting 1: User can use PG card with Encoder to do close-loop speed control.

Setting 2: To have optimal control characteristic by auto-tuning.

Setting 3: To increase torque and control speed precisely. (1:1000)

Setting 4: To increase accuracy for torque control.

Setting 8: To increase torque and control speed precisely. (1:1000). This setting is only for using with permanent magnet motor and others are for induction motor.

➤ **00-10** Sped Unit

Control Mode **VF** **VFPG** **SVC** **FOCPG** **TQCPG** **FOCPM** Factory Setting:0

Settings 0 : Hz
1 : m/s
2 : ft/s

➤ **00-11** Output Direction Selection

Control Mode **VF** **VFPG** **SVC** **FOCPG** **TQCPG** **FOCPM** Factory Setting:0

Settings 0: FWD: counterclockwise, REV: clockwise
1: FWD: clockwise, REV: counterclockwise

➤ **00-12** Carrier Frequency

Control Mode **VF** **VFPG** **SVC** **FOCPG** **TQCPG** **FOCPM** Factory Setting:12

Settings 2~15kHz

📖 This parameter determinates the PWM carrier frequency of the AC motor drive.

Models	5HP	7.5-15HP	20-30HP	40-60HP	75-100HP
Settings	2~ 15kHz	2~ 15kHz	2~15kHz	2~ 9kHz	2~ 6kHz
Factory Seeting	8 kHz	10kHz	8kHz	6kHz	6kHz

Carrier Frequency	Acoustic Noise	Electromagnetic Noise or Leakage Current	Heat Dissipation	Current Wave
2kHz	Significant ↑ ↓ Minimal	Minimal ↑ ↓ Significant	Minimal ↑ ↓ Significant	
8kHz				
15kHz				

📖 From the table, we see that the PWM carrier frequency has a significant influence on the electromagnetic noise, AC motor drive heat dissipation, and motor acoustic noise.

📖 If the carrier frequency are set to be higher than the factory settings in the table above, the motor drive will derate its capacity. See Derating Capacity of Carrier Frequency(Fc) in CH02.

➤ **00-13** Auto Voltage Regulation (AVR) Function

Control Mode **VF** **VFPG** **SVC** **FOCPG** **TQCPG** **FOCPM** Factory Setting:0

Settings 0: Enable AVR
1: Disable AVR
2: Disable AVR when deceleration stop

📖 It is used to select the AVR mode. AVR is used to regulate the output voltage to the motor. For example, if V/f curve is set to AC200V/50Hz and the input voltage is from 200 to 264VAC, the output voltage won't

excess AC200V/50Hz. If the input voltage is from 180 to 200V, the output voltage to the motor and the input voltage will be in direct proportion.

- 📖 When setting Pr.00-13 to 1 during ramp to stop and used with auto accel./decel. function, the acceleration will be smoother and faster.

⚡ 00-14 Source of the Master Frequency Command

Control Mode **VF** **VFPG** **SVC** **FOCPG** **FOCPM** Factory Setting:1

- Settings
- 1: RS-485 serial communication or digital keypad (KPC-CC01)
 - 2: External analog input (Pr. 03-00)
 - 3: Digital terminals input (Pr.04-00~04-15)

- 📖 This parameter determines the drive's master frequency source.

⚡ 00-15 Source of the Operation Command

Control Mode **VF** **VFPG** **SVC** **FOCPG** **TQCPG** **FOCPM** Factory Setting:1

- Settings
- 1: External terminals
 - 2: RS-485 serial communication or digital keypad (KPC-CC01)

- 📖 ED series is shipped without digital keypad and users can use external terminals or RS-485 to control the operation command.

- 📖 When the LED PU is light, the operation command can be controlled by the optional digital keypad (KPC-CC01).

01 Basic Parameters

01-00 Maximum Output Frequency

Control Mode **VF** **VFP** **SVC** **FOCPG** **TQCPG** **FOCPM**

Factory

Setting:60.00/50.00

Settings 10.00~400.00Hz

 This parameter determines the AC motor drive's Maximum Output Frequency. All the AC motor drive frequency command sources (analog inputs -10V to +10V) are scaled to correspond to the output frequency range.

01-01 1st Output Frequency Setting (base frequency/ motor's rated frequency)

Control Mode **VF** **VFP** **SVC** **FOCPG** **TQCPG** **FOCPM**

Factory Setting:60.00/50.00

Settings 0.00~400.00Hz

 This value should be set according to the rated frequency of the motor as indicated on the motor nameplate. If the motor is 60Hz, the setting should be 60Hz. If the motor is 50Hz, it should be set to 50Hz.

01-02 1st Output Voltage Setting(base voltage/ motor's rated voltage)

Control Mode **VF** **VFP** **SVC** **FOCPG** **TQCPG** **FOCPM**

Factory

Setting:220.0/440.0

Settings 230V series 0.1~255.0V

460V series 0.1~510.0V

 This value should be set according to the rated voltage of the motor as indicated on the motor nameplate. If the motor is 220V, the setting should be 220.0. If the motor is 200V, it should be set to 200.0.

 There are many motor types in the market and the power system for each country is also difference. The economic and convenience method to solve this problem is to install the AC motor drive. There is no problem to use with the different voltage and frequency and also can amplify the original characteristic and life of the motor.

01-03 2nd Output Frequency Setting

Control Mode **VF** **VFP**

Factory Setting:0.50

Settings 0.00~400.00Hz

01-04 2nd Output Voltage Setting

Control Mode **VF** **VFP**

Factory Setting:5.0/10.0

Settings 230V series 0.1~255.0V

460V series 0.1~510.0V

01-05 3rd Output Frequency Setting

Control Mode **VF** **VFP**

Factory Setting:0.50

Settings 0.00~400.00Hz

01-06 3rd Output Voltage Setting

Control Mode **VF** **VFP**

Factory Setting:5.0/10.0

Settings 230V series 0.1~255.0V

460V series 0.1~510.0V

01-07 4th Output Frequency Setting

Control Mode **VF** **VFP** **SVC** **FOCPG** **TQCPG**

Factory Setting:0.00

Settings 0.00~400.00Hz

01-08 4th Output Voltage Setting

Control Mode **VF** **VFP**

Factory Setting:5.0/10.0

Settings 230V series 0.1~255.0V
460V series 0.1~510.0V

- V/f curve setting is usually set by the motor's allowable loading characteristics. Pay special attention to the motor's heat dissipation, dynamic balance, and bearing lubricity, if the loading characteristics exceed the loading limit of the motor.
- For the V/f curve setting, it should be $Pr.01-01 \geq Pr.01-03 \geq Pr.01-05 \geq Pr.01-07$. There is no limit for the voltage setting, but a high voltage at the low frequency may cause motor damage, overheat, stall prevention or over-current protection. Therefore, please use the low voltage at the low frequency to prevent motor damage.

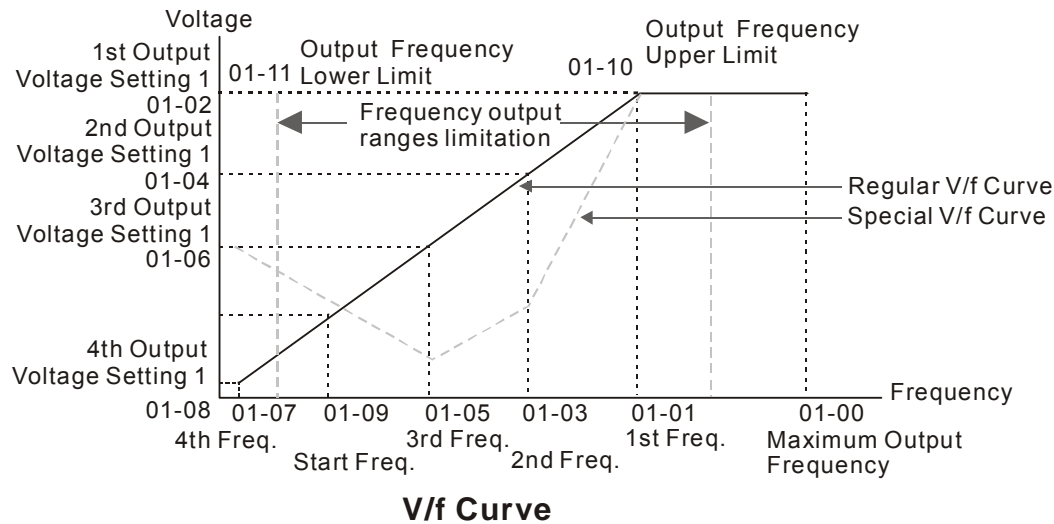

01-09 Starting Frequency
Control Mode **VF** **VFP** **SVC** **FOCP** **FOCPM** Factory Setting:0.50
Settings 0.00~400.00Hz

當啟動頻率大於最小輸出頻率時，變頻器的輸出將從啟動頻率到設定頻率。

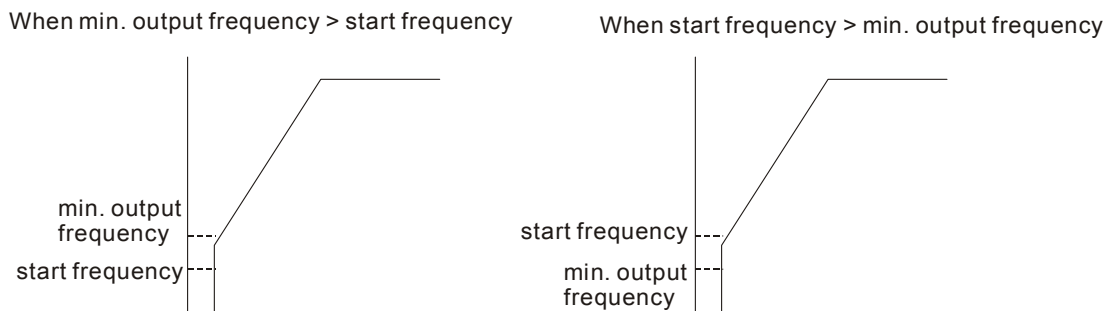





01-10 Output Frequency Upper Limit
Control Mode **VF** **VFP** **SVC** **FOCP** **FOCPM** Factory Setting:120.00
Settings 0.00~400.00Hz

01-11 Output Frequency Lower Limit
Control Mode **VF** **VFP** **SVC** **FOCP** **FOCPM** Factory Setting:0.00
Settings 0.00~400.00Hz

The upper/lower output frequency setting is used to limit the actual output frequency. If the frequency setting is lower than the start-up frequency, it will run with zero speed. If the frequency setting is higher than the upper limit, it will runs with the upper limit frequency. If output frequency lower limit > output frequency upper limit, this function is invalid.

↘	01-12	Accel. Time 1					
	Control Mode	VF	VFPG	SVC	FOCPG	FOCPM	Factory Setting:3.00
	Settings	0.00~600.00sec					
↘	01-13	Decel. Time 1					
	Control Mode	VF	VFPG	SVC	FOCPG	FOCPM	Factory Setting:2.00
	Settings	0.00~600.00sec					
↘	01-14	Accel. Time 2					
	Control Mode	VF	VFPG	SVC	FOCPG	FOCPM	Factory Setting:3.00
	Settings	0.00~600.00sec					
↘	01-15	Decel. Time 2					
	Control Mode	VF	VFPG	SVC	FOCPG	FOCPM	Factory Setting:2.00
	Settings	0.00~600.00sec					
↘	01-16	Accel. Time 3					
	Control Mode	VF	VFPG	SVC	FOCPG	FOCPM	Factory Setting:3.00
	Settings	0.00~600.00sec					
↘	01-17	Decel. Time 3					
	Control Mode	VF	VFPG	SVC	FOCPG	FOCPM	Factory Setting:2.00
	Settings	0.00~600.00sec					
↘	01-18	Accel. Time 4					
	Control Mode	VF	VFPG	SVC	FOCPG	FOCPM	Factory Setting:3.00
	Settings	0.00~600.00sec					
↘	01-19	Decel. Time 4					
	Control Mode	VF	VFPG	SVC	FOCPG	FOCPM	Factory Setting:2.00
	Settings	0.00~600.00sec					

-  The Acceleration Time is used to determine the time required for the AC motor drive to ramp from 0Hz to Maximum Output Frequency (Pr.01-00).
-  The Deceleration Time is used to determine the time require for the AC motor drive to decelerate from the Maximum Output Frequency (Pr.01-00) down to 0Hz.
-  The Acceleration/Deceleration Time 1, 2, 3, 4 are selected according to the Multi-function Input Terminals settings. The factory settings are acceleration time 1 and deceleration time 1.
-  The larger against torque and inertia torque of the load and the accel./decel. time setting is less than the necessary value, it will enable torque limit and stall prevention function. When it happens, actual accel./decel. time will be longer than the action above.

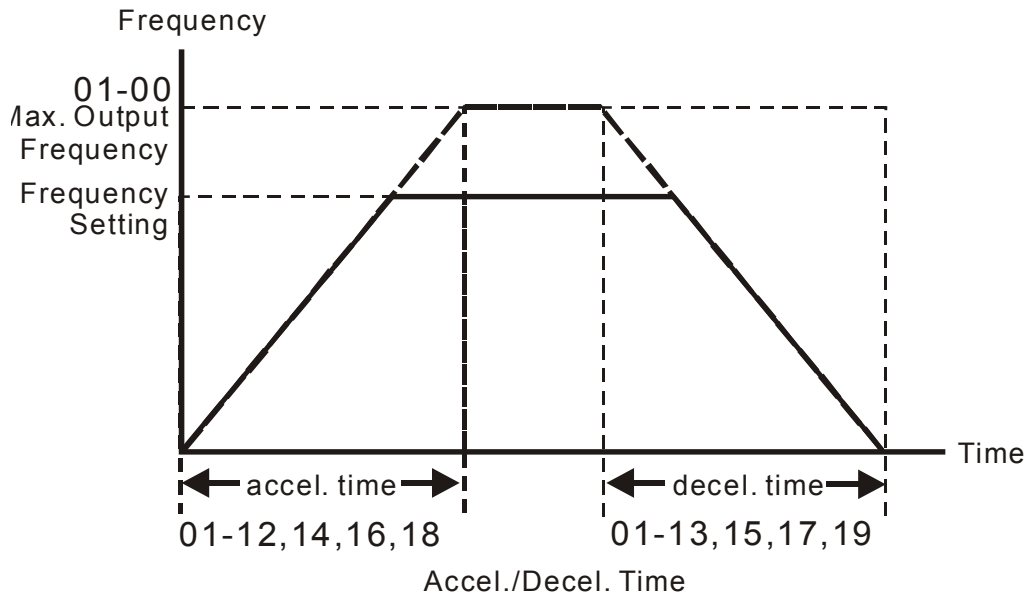

- **01-20** JOG Acceleration Time
- **01-21** JOG Deceleration Time

Control Mode **VF VFPG SVC FOCPG FOCPM** Factory Setting:1.00
 Settings 0.00~600.00sec

- 📖 Both external terminal JOG and key “JOG” on the keypad can be used. When the jog command is ON, the AC motor drive will accelerate from 0Hz (Pr01-07) to jog frequency (Pr.01-22). When the jog command is OFF, the AC motor drive will decelerate from Jog Frequency to zero. The used Accel./Decel. time is set by the Jog Accel./Decel. time (Pr.01-20, Pr.01-21).
- 📖 The JOG command can't be executed when the AC motor drive is running. In the same way, when the JOG command is executing, other operation commands are invalid except forward/reverse commands and STOP key on the digital keypad.

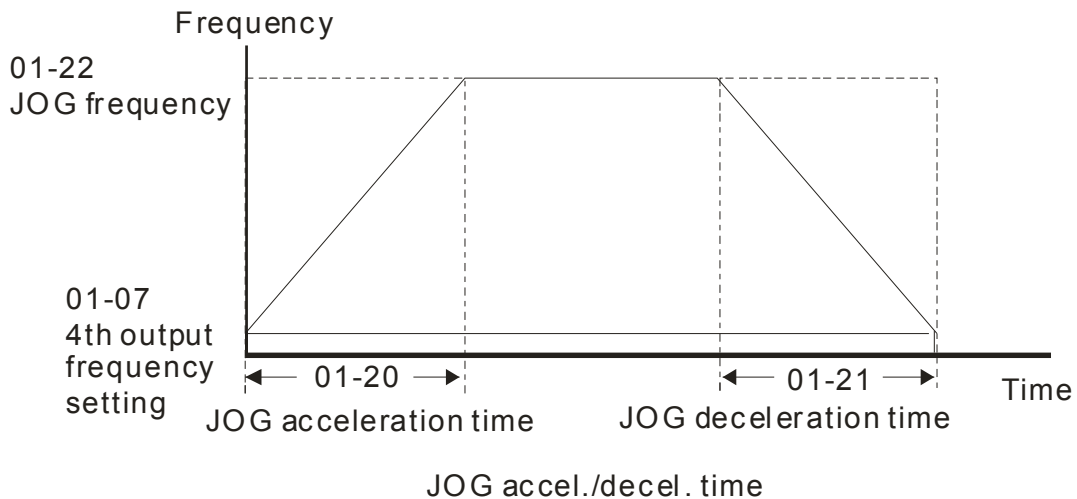

- **01-22** JOG Frequency
- Control Mode **VF VFPG SVC FOCPG TQCPG FOCPM** Factory Setting:6.00
 Settings 0.00~400.00Hz

➤ **01-23** Switch Frequency between 1st/4th Accel/decel

Control Mode **VF** **VFPG** **SVC** **FOCPG** **FOCPM** Factory Setting:0.00
 Settings 0.00~400.00Hz

- 📖 This parameter selects the frequency point for transition from acceleration/deceleration time 1 to acceleration/deceleration time 4.
- 📖 The transition from acceleration/deceleration time 1 to acceleration/deceleration time 4, may also be enabled by the external terminals (Pr. 02-01 to 02-08). The external terminal has priority over Pr. 01-23.

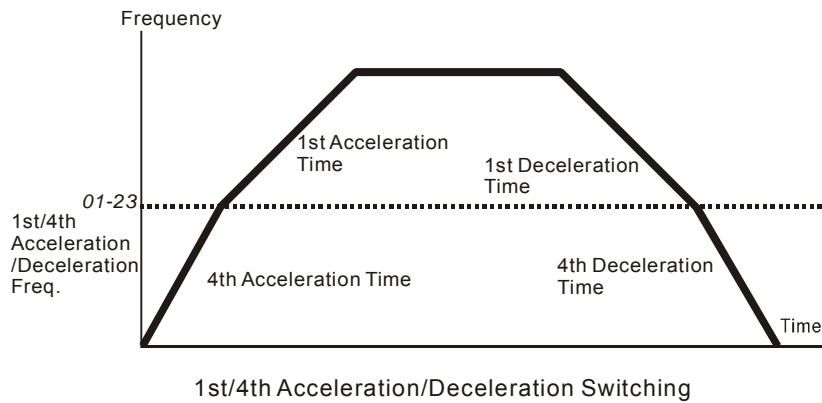

➤ **01-24** S-curve for Acceleration Departure Time S1

➤ **01-25** S-curve for Acceleration Arrival Time S2

➤ **01-26** S-curve for Deceleration Departure Time S3

➤ **01-27** S-curve for Deceleration Arrival Time S4

➤ **01-30** S-curve for Deceleration Arrival Time S5

Control Mode **VF** **VFPG** **SVC** **FOCPG** **FOCPM** Factory Setting:1.00
 Settings 0.00~25.00sec

➤ **01-29** Switch Frequency for S3/S4 Changes to S5

Control Mode **VF** **VFPG** **SVC** **FOCPG** **FOCPM** Factory Setting:0.00
 Settings 0.00~400.00Hz

- 📖 It is used to give the smoothest transition between speed changes. The accel./decel. curve can adjust the S-curve of the accel./decel. When it is enabled, the drive will have different accel./decel. curve by the accel./decel. time.
- 📖 The Actual Accel. Time = selected accel. Time + (Pr.01-24 + Pr.01-25)/2
 The Actual Decel. Time = selected decel. Time + (Pr.01-26 + Pr.01-27 + Pr.01-30*2)/2
- 📖 Pr.01-29 is used to set the switch frequency between S4 and S5 for smooth stop.
- 📖 It is recommended to set this parameter to the leveling speed of elevator.

02 Digital Input/Output Parameters

02-00

2-wire/3-wire Operation Control

Control Mode **VF** **VFP** **SVC** **FOCP** **TQCP** **FOCP**

Factory Setting:0

- Settings 0: FWD/STOP, REV/STOP
 1: FWD/STOP, REV/STOP (Line Start Lockout)
 2: RUN/STOP, REV/FWD
 3: RUN/STOP, REV/FWD (Line Start Lockout)
 4: 3-wire
 5: 3-wire (Line Start Lockout)

- ☰ Three of the six methods include a “Line Start Lockout” feature. When line start lockout is enabled, the drive will not run once applying the power. The Line Start Lockout feature doesn’t guarantee the motor will never start under this condition. It is possible the motor may be set in motion by a malfunctioning switch.
- ☰ This parameter is used to control operation from external terminals. There are three different control modes.

02-00	Control Circuits of the External Terminal
0, 1 2-wire operation control (1) FWD/STOP REV/STOP	
2, 3 2-wire operation control (2) RUN/STOP REV/FWD	
4, 5 3-wire operation control	

02-01	Multi-Function Input Command 1 (MI1) (it is Stop terminal for 3-wire operation)	Factory Setting:1
02-02	Multi-Function Input Command 2 (MI2)	Factory Setting:2
02-03	Multi-Function Input Command 3 (MI3)	Factory Setting:3
02-04	Multi-Function Input Command 4 (MI4)	Factory Setting:4
02-05	Multi-Function Input Command 5 (MI5)	Factory Setting:0
02-06	Multi-Function Input Command 6 (MI6)	Factory Setting:0
02-07	Multi-Function Input Command 7 (MI7)	Factory Setting:0
02-08	Multi-Function Input Command 8 (MI8) When JP1 on the control board is inserted, MI8 functions acc. to Pr02-08. When JP1 on the control board is removed, MI8 is always "enable", independent of Pr02-08.	Factory Setting:40

Settings	Control Mode	VF	VFPG	SVC	FOCPG	TQCPG	FOCPM
0:0: no function		<input type="radio"/>	<input type="radio"/>	<input type="radio"/>	<input type="radio"/>	<input type="radio"/>	<input type="radio"/>
1: multi-step speed command 1		<input type="radio"/>	<input type="radio"/>	<input type="radio"/>	<input type="radio"/>		<input type="radio"/>
2: multi-step speed command 2		<input type="radio"/>	<input type="radio"/>	<input type="radio"/>	<input type="radio"/>		<input type="radio"/>
3: multi-step speed command 3		<input type="radio"/>	<input type="radio"/>	<input type="radio"/>	<input type="radio"/>		<input type="radio"/>
4: multi-step speed command 4		<input type="radio"/>	<input type="radio"/>	<input type="radio"/>	<input type="radio"/>		<input type="radio"/>
5: Reset		<input type="radio"/>	<input type="radio"/>	<input type="radio"/>	<input type="radio"/>	<input type="radio"/>	<input type="radio"/>
6: JOG command		<input type="radio"/>	<input type="radio"/>	<input type="radio"/>	<input type="radio"/>		<input type="radio"/>
7: acceleration/deceleration speed inhibit		<input type="radio"/>	<input type="radio"/>	<input type="radio"/>	<input type="radio"/>		<input type="radio"/>
8: the 1st, 2nd acceleration/deceleration time selection		<input type="radio"/>	<input type="radio"/>	<input type="radio"/>	<input type="radio"/>		<input type="radio"/>
9: the 3rd, 4th acceleration/deceleration time selection		<input type="radio"/>	<input type="radio"/>	<input type="radio"/>	<input type="radio"/>		<input type="radio"/>
10: EF input (07-28)		<input type="radio"/>	<input type="radio"/>	<input type="radio"/>	<input type="radio"/>	<input type="radio"/>	<input type="radio"/>
11: Reserved							
12: Stop output		<input type="radio"/>	<input type="radio"/>	<input type="radio"/>	<input type="radio"/>	<input type="radio"/>	<input type="radio"/>
13~14: Reserved							
15: AUI1 operation speed command form AUI1		<input type="radio"/>	<input type="radio"/>	<input type="radio"/>	<input type="radio"/>		<input type="radio"/>
16: Reserved		<input type="radio"/>	<input type="radio"/>	<input type="radio"/>	<input type="radio"/>		<input type="radio"/>
17: AUI2 operation speed command form AUI2		<input type="radio"/>	<input type="radio"/>	<input type="radio"/>	<input type="radio"/>		<input type="radio"/>
18: Emergency Stop (07-28)		<input type="radio"/>	<input type="radio"/>	<input type="radio"/>	<input type="radio"/>	<input type="radio"/>	<input type="radio"/>
19~23: Reserved							

24: FWD JOG Command	<input type="radio"/>	<input type="radio"/>	<input type="radio"/>	<input type="radio"/>	<input type="radio"/>	<input type="radio"/>
25: REV JOG Command	<input type="radio"/>	<input type="radio"/>	<input type="radio"/>	<input type="radio"/>	<input type="radio"/>	<input type="radio"/>
26: Reserved						
27: ASR1/ASR2 selection	<input type="radio"/>	<input type="radio"/>	<input type="radio"/>	<input type="radio"/>	<input type="radio"/>	<input type="radio"/>
28: Emergency stop (EF1) (Motor coasts to stop)	<input type="radio"/>	<input type="radio"/>	<input type="radio"/>	<input type="radio"/>	<input type="radio"/>	<input type="radio"/>
29~30: Reserved						
31: High torque bias (by Pr.07-21)	<input type="radio"/>	<input type="radio"/>	<input type="radio"/>	<input type="radio"/>	<input type="radio"/>	<input type="radio"/>
32: Middle torque bias (by Pr.07-22)	<input type="radio"/>	<input type="radio"/>	<input type="radio"/>	<input type="radio"/>	<input type="radio"/>	<input type="radio"/>
33: Low torque bias (by Pr.07-23)	<input type="radio"/>	<input type="radio"/>	<input type="radio"/>	<input type="radio"/>	<input type="radio"/>	<input type="radio"/>
34~37: Reserved						
38: Disable write EEPROM function	<input type="radio"/>	<input type="radio"/>	<input type="radio"/>	<input type="radio"/>	<input type="radio"/>	<input type="radio"/>
39: Torque command direction					<input type="radio"/>	
40: Enable drive function	<input type="radio"/>	<input type="radio"/>	<input type="radio"/>	<input type="radio"/>	<input type="radio"/>	<input type="radio"/>
41: Detection of magnetic contactor		<input type="radio"/>	<input type="radio"/>	<input type="radio"/>	<input type="radio"/>	<input type="radio"/>
42: Mechanical brake	<input type="radio"/>	<input type="radio"/>	<input type="radio"/>	<input type="radio"/>	<input type="radio"/>	<input type="radio"/>
43: EPS function (Emergency Power System)	<input type="radio"/>	<input type="radio"/>	<input type="radio"/>	<input type="radio"/>	<input type="radio"/>	<input type="radio"/>

 This parameter selects the functions for each multi-function terminal.

 If Pr.02-00 is set to 3-wire operation control. Terminal MI1 is for STOP terminal. Therefore, MI1 is not allowed for any other operation.

Settings	Functions	Descriptions									
0	No Function										
1	Multi-step speed command 1	15 step speeds could be conducted through the digital statuses of the 4 terminals, and 17 in total if the master speed and JOG are included. (Refer to Pr. 04-00~04-14) When using communication to control the multi-step speed, setting 1 to 4 will be invalid.									
2	Multi-step speed command 2										
3	Multi-step speed command 3										
4	Multi-step speed command 4										
5	Reset	After the error of the drive is eliminated, use this terminal to reset the drive.									
6	JOG Command	JOG operation									
7	Acceleration/deceleration Speed Inhibit	When this function is enabled, acceleration and deceleration is stopped and the AC motor drive starts to accel./decel. from the inhibit point.									
8	The 1 st , 2 nd acceleration or deceleration time selection	The acceleration/deceleration time of the drive could be selected from this function or the digital statuses of the terminals; there are 4 acceleration/deceleration speeds in total for selection. <table border="1" style="margin-left: 20px;"> <tr> <td>Bit</td> <td>Bit</td> <td>Descriptions</td> </tr> <tr> <td>0</td> <td>1</td> <td></td> </tr> <tr> <td>0</td> <td>0</td> <td>First acceleration/deceleration time</td> </tr> </table>	Bit	Bit	Descriptions	0	1		0	0	First acceleration/deceleration time
Bit	Bit	Descriptions									
0	1										
0	0	First acceleration/deceleration time									

9	The 3 rd , 4 th acceleration or deceleration time selection	<p>When output frequency is less than Pr.01-23 (Switch Frequency between 1st/4th Accel/decel), it will output 4th accel/decel time.</p> <table border="0"> <tr> <td>0</td> <td>1</td> <td>2nd accel./decel. time</td> </tr> <tr> <td>1</td> <td>0</td> <td>3rd accel./decel. time</td> </tr> <tr> <td>1</td> <td>1</td> <td>4th accel./decel. time</td> </tr> </table> <p>If the drive receives STOP command, it will decelerate to stop by Pr.01-31.</p>	0	1	2 nd accel./decel. time	1	0	3 rd accel./decel. time	1	1	4 th accel./decel. time
0	1	2 nd accel./decel. time									
1	0	3 rd accel./decel. time									
1	1	4 th accel./decel. time									
10	EF Input	External fault input terminal and decelerates by Pr.07-28. (EF fault will be recorded)									
11: Reserved											
12	Stop output	When this function is enabled, the drive output will stop immediately and the motor is free run. When this function is disabled, the drive will accelerate to the frequency setting.									
13~14: Reserved											
15	Operation speed command form AUI1	<p>When the source of operation speed command is set to AUI1, ACI and AUI2 at the same time and two or above terminals are ON, the priority is AUI1>ACI>AUI2.</p> <p>When this function is enabled, the source of the frequency will force to be AUI1.</p>									
16: Reserved											
17	Operation speed command form AUI2	When this function is enabled, the source of the frequency will force to be AUI2.									
18	Emergency Stop	When this function is enabled, the drive will ramp to stop by Pr.07-28 setting.									
19~23: Reserved											
24	FWD JOG command	When this function is enabled, the drive will execute forward Jog command.									
25	REV JOG command	When this function is enabled, the drive will execute reverse Jog command.									
26: Reserved											
27	ASR1/ASR2 selection	<p>ON: speed will be adjusted by ASR 2 setting.</p> <p>OFF: speed will be adjusted by ASR 1 setting.</p>									
28	Emergency stop (EF1) (Motor coasts to stop)	When it is ON, the drive will execute emergency stop. (it will have fault code record)									
29~30: Reserved											
31	High torque bias	<p>When Pr.07-19 is set to 3:</p> <p>The high torque bias is according to the Pr.07-21 setting.</p>									

32	Middle torque bias	The middle torque bias is according to the Pr.07-22 setting. The low torque bias is according to the Pr.07-23 setting.																																				
33	Low torque bias	<table border="1"> <thead> <tr> <th>31</th> <th>32</th> <th>33</th> <th>Torque Bias</th> </tr> </thead> <tbody> <tr> <td>OFF</td> <td>OFF</td> <td>OFF</td> <td>N/A</td> </tr> <tr> <td>OFF</td> <td>OFF</td> <td>ON</td> <td>07-23</td> </tr> <tr> <td>OFF</td> <td>ON</td> <td>OFF</td> <td>07-22</td> </tr> <tr> <td>OFF</td> <td>ON</td> <td>ON</td> <td>07-23+07-22</td> </tr> <tr> <td>ON</td> <td>OFF</td> <td>OFF</td> <td>07-21</td> </tr> <tr> <td>ON</td> <td>OFF</td> <td>ON</td> <td>07-21+07-23</td> </tr> <tr> <td>ON</td> <td>ON</td> <td>OFF</td> <td>07-21+07-22</td> </tr> <tr> <td>ON</td> <td>ON</td> <td>ON</td> <td>07-21+07-22+07-23</td> </tr> </tbody> </table>	31	32	33	Torque Bias	OFF	OFF	OFF	N/A	OFF	OFF	ON	07-23	OFF	ON	OFF	07-22	OFF	ON	ON	07-23+07-22	ON	OFF	OFF	07-21	ON	OFF	ON	07-21+07-23	ON	ON	OFF	07-21+07-22	ON	ON	ON	07-21+07-22+07-23
31	32	33	Torque Bias																																			
OFF	OFF	OFF	N/A																																			
OFF	OFF	ON	07-23																																			
OFF	ON	OFF	07-22																																			
OFF	ON	ON	07-23+07-22																																			
ON	OFF	OFF	07-21																																			
ON	OFF	ON	07-21+07-23																																			
ON	ON	OFF	07-21+07-22																																			
ON	ON	ON	07-21+07-22+07-23																																			
34~37: Reserved																																						
38	Disable write EEPROM function	When this function is enabled, you can't write into EEPROM.																																				
39	Torque command direction	When this function is enabled, you can't write into EEPROM.																																				
40	Enable drive function	When Pr.07-13=2 and analog input is ACI or unipolar AUI, torque command direction is decided by this terminal.																																				
41	Detection of magnetic contactor	When this function is enabled, the drive function can be executed. This function can be used with multi-function output (setting Pr.02-11~Pr.02-14 to 15) and (Pr.02-31 and Pr.02-32).																																				
42	Mechanical brake	This terminal is used for the feedback signal of magnetic contactor ON/OFF. When drive receives RUN command, the corresponding output terminal (setting 15) will be enabled after Pr.02-31 time. It will check if this function is enabled within the detection time (Pr.02-36). If NOT, the fault of mechanical brake occurs and fault code "MCF" will be displayed.																																				
43	EPS function (Emergency Power System)	If power is cut during running, the drive will stop when DC bus voltage is less than low voltage level. After power is cut, drive will run by the frequency depend on EPS when EPS is applied and this function is ON.																																				

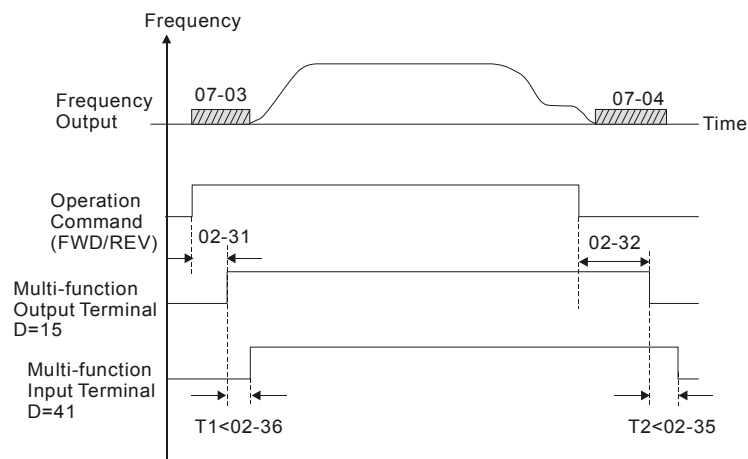

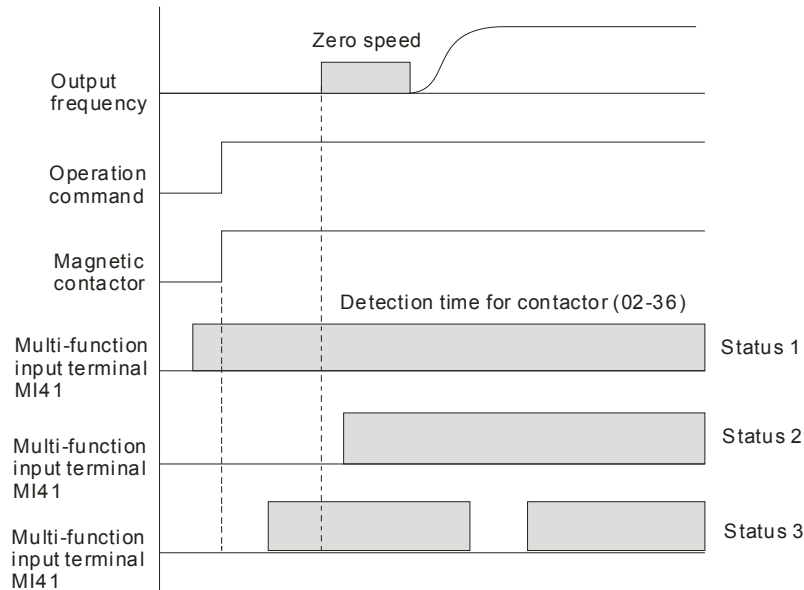

02-09 Digital Input Response Time

Control Mode **VF VFPG SVC FOC PG TQCPG FOC PM** Factory Setting:0.005
 Settings 0.001~30.000sec

This parameter is used for digital input terminal signal delay and confirmation. The delay time is confirmation time to prevent some uncertain interferences that would result in error (except for the counter input) in the input of the digital terminals (FWD, REV and MI1~8). Under this condition, confirmation for this parameter could be improved effectively, but the response time will be somewhat delayed.

02-10 Digital Input Operation Direction

Control Mode **VF VFPG SVC FOC PG TQCPG FOC PM** Factory Setting:0
 Settings 0~65535

- ☰ This parameter is used to set the input signal level and it won't be affected by the SINK/SOURCE status.
- ☰ Bit0 is for FWD terminal, bit1 is for REV terminal and bit2 to bit9 is for MI1 to MI8.
- ☰ User can change terminal status by communicating.
 For example, MI1 is set to 1 (multi-step speed command 1), MI2 is set to 2 (multi-step speed command 2). Then the forward + 2nd step speed command=1001(binary)=9 (Decimal). Only need to set Pr.02-10=9 by communication and it can forward with 2nd step speed. It doesn't need to wire any multi-function terminal.

bit9	bit8	bit7	bit6	bit5	bit4	bit3	bit2	bit1	bit0
MI8	MI7	MI6	MI5	MI4	MI3	MI2	MI1	REV	FWD

↘	02-11	Multi-function Output 1 RA, RB, RC (Relay1)	Factory Setting:11
↘	02-12	Multi-function Output 2 MRA, MRC (Relay2)	Factory Setting:1
↘	02-13	Multi-function Output 3 R1A(Realy 3)	
↘	02-14	Multi-function Output 4 R2A(Realy 4)	
↘	02-15	Multi-function Output 5 MO1	
↘	02-16	Multi-function Output 6 MO2	
↘	02-17	Reserved	
↘	02-18	Reserved	
↘	02-19	Reserved	
↘	02-20	Reserved	
↘	02-21	Reserved	
↘	02-22	Reserved	

Factory Setting:0

Settings	Control Mode	VF	VFPG	SVC	FOCPG	TQCPG	FOCPM
0: No function		<input type="radio"/>	<input type="radio"/>	<input type="radio"/>	<input type="radio"/>	<input type="radio"/>	<input type="radio"/>
1: Operation indication		<input type="radio"/>	<input type="radio"/>	<input type="radio"/>	<input type="radio"/>	<input type="radio"/>	<input type="radio"/>
2: Operation speed attained		<input type="radio"/>	<input type="radio"/>	<input type="radio"/>	<input type="radio"/>	<input type="radio"/>	<input type="radio"/>
3: Desired frequency attained 1 (Pr.02-25, 02-26)		<input type="radio"/>	<input type="radio"/>	<input type="radio"/>	<input type="radio"/>	<input type="radio"/>	<input type="radio"/>
4: Desired frequency attained 2 (Pr.02-27, 02-28)		<input type="radio"/>	<input type="radio"/>	<input type="radio"/>	<input type="radio"/>	<input type="radio"/>	<input type="radio"/>
5: Zero Speed(frequency command		<input type="radio"/>	<input type="radio"/>	<input type="radio"/>	<input type="radio"/>	<input type="radio"/>	<input type="radio"/>
6: Zero speed with stop (frequency command)		<input type="radio"/>	<input type="radio"/>	<input type="radio"/>	<input type="radio"/>	<input type="radio"/>	<input type="radio"/>
7: Over torque (OT1) (Pr.06-05~06-07)		<input type="radio"/>	<input type="radio"/>	<input type="radio"/>	<input type="radio"/>	<input type="radio"/>	<input type="radio"/>
8: Over torque (OT2) (Pr.06-08~06-10)		<input type="radio"/>	<input type="radio"/>	<input type="radio"/>	<input type="radio"/>	<input type="radio"/>	<input type="radio"/>
9: Drive ready		<input type="radio"/>	<input type="radio"/>	<input type="radio"/>	<input type="radio"/>	<input type="radio"/>	<input type="radio"/>
10: User-defined Low-voltage Detection (LV)		<input type="radio"/>	<input type="radio"/>	<input type="radio"/>	<input type="radio"/>	<input type="radio"/>	<input type="radio"/>
11: Malfunction indication		<input type="radio"/>	<input type="radio"/>	<input type="radio"/>	<input type="radio"/>	<input type="radio"/>	<input type="radio"/>
12: Mechanical brake release (Pr.02-29, Pr.02-30)		<input type="radio"/>	<input type="radio"/>	<input type="radio"/>	<input type="radio"/>	<input type="radio"/>	<input type="radio"/>
13: Overheat (Pr.06-14)		<input type="radio"/>	<input type="radio"/>	<input type="radio"/>	<input type="radio"/>	<input type="radio"/>	<input type="radio"/>
14: Brake chopper signal		<input type="radio"/>	<input type="radio"/>	<input type="radio"/>	<input type="radio"/>	<input type="radio"/>	<input type="radio"/>
15: Motor-controlled magnetic contactor output		<input type="radio"/>	<input type="radio"/>	<input type="radio"/>	<input type="radio"/>	<input type="radio"/>	<input type="radio"/>
16: Slip error (oSL)		<input type="radio"/>	<input type="radio"/>	<input type="radio"/>	<input type="radio"/>	<input type="radio"/>	<input type="radio"/>
17: Malfunction indication 1		<input type="radio"/>	<input type="radio"/>	<input type="radio"/>	<input type="radio"/>	<input type="radio"/>	<input type="radio"/>
18: Reserved							
19: Brake chopper output error		<input type="radio"/>	<input type="radio"/>	<input type="radio"/>	<input type="radio"/>	<input type="radio"/>	<input type="radio"/>
20: Warning output		<input type="radio"/>	<input type="radio"/>	<input type="radio"/>	<input type="radio"/>	<input type="radio"/>	<input type="radio"/>
21: Over voltage warning		<input type="radio"/>	<input type="radio"/>	<input type="radio"/>	<input type="radio"/>	<input type="radio"/>	<input type="radio"/>
22: Over-current stall prevention warning		<input type="radio"/>	<input type="radio"/>	<input type="radio"/>	<input type="radio"/>	<input type="radio"/>	<input type="radio"/>
23: Over-voltage stall prevention warning		<input type="radio"/>	<input type="radio"/>	<input type="radio"/>	<input type="radio"/>	<input type="radio"/>	<input type="radio"/>
24: Operation mode indication (Pr.00-15≠0)		<input type="radio"/>	<input type="radio"/>	<input type="radio"/>	<input type="radio"/>	<input type="radio"/>	<input type="radio"/>

25: Forward command	<input type="radio"/>	<input type="radio"/>	<input type="radio"/>	<input type="radio"/>	<input type="radio"/>	<input type="radio"/>
26: Reverse command	<input type="radio"/>	<input type="radio"/>	<input type="radio"/>	<input type="radio"/>	<input type="radio"/>	<input type="radio"/>
27: Output when current \geq Pr.02-33	<input type="radio"/>	<input type="radio"/>	<input type="radio"/>	<input type="radio"/>	<input type="radio"/>	<input type="radio"/>
28: Output when current $<$ Pr.02-33	<input type="radio"/>	<input type="radio"/>	<input type="radio"/>	<input type="radio"/>	<input type="radio"/>	<input type="radio"/>
29: Output when frequency \geq Pr.02-34	<input type="radio"/>	<input type="radio"/>	<input type="radio"/>	<input type="radio"/>	<input type="radio"/>	<input type="radio"/>
30: Output when frequency $<$ Pr.02-34	<input type="radio"/>	<input type="radio"/>	<input type="radio"/>	<input type="radio"/>	<input type="radio"/>	<input type="radio"/>
31: Power generation direction and status verify	<input type="radio"/>	<input type="radio"/>	<input type="radio"/>	<input type="radio"/>	<input type="radio"/>	<input type="radio"/>
32: Power generation direction	<input type="radio"/>	<input type="radio"/>	<input type="radio"/>	<input type="radio"/>	<input type="radio"/>	<input type="radio"/>
33: Zero speed (actual output frequency)	<input type="radio"/>	<input type="radio"/>	<input type="radio"/>	<input type="radio"/>		<input type="radio"/>
34: Zero speed with Stop (actual output frequency)	<input type="radio"/>	<input type="radio"/>	<input type="radio"/>	<input type="radio"/>		<input type="radio"/>
35: Fault output option 1 (Pr.06-22)	<input type="radio"/>	<input type="radio"/>	<input type="radio"/>	<input type="radio"/>	<input type="radio"/>	<input type="radio"/>
36: Fault output option 2 (Pr.06-23)	<input type="radio"/>	<input type="radio"/>	<input type="radio"/>	<input type="radio"/>	<input type="radio"/>	<input type="radio"/>
37: Fault output option 3 (Pr.06-24)	<input type="radio"/>	<input type="radio"/>	<input type="radio"/>	<input type="radio"/>	<input type="radio"/>	<input type="radio"/>
38: Fault output option 4 (Pr.06-25)	<input type="radio"/>	<input type="radio"/>	<input type="radio"/>	<input type="radio"/>	<input type="radio"/>	<input type="radio"/>
39: Reserved						
40: Speed attained (including zero speed)	<input type="radio"/>	<input type="radio"/>	<input type="radio"/>	<input type="radio"/>		<input type="radio"/>
41: Reserved						
42: SO Logice Output A						

Settings	Functions	Descriptions
0	No Function	No function
1	AC Drive Operational	Active when there is an output from the drive or RUN command is ON.
2	Operation speed attained	Active when the AC motor drive reaches the output frequency setting.
3	Desired Frequency Attained 1 (Pr.02-25, 02-26)	Active when the desired frequency (Pr.02-25, 02-26) is attained.
4	Desired Frequency Attained 2 (Pr.02-27, 02-28)	Active when the desired frequency (Pr.02-27, 02-28) is attained.
5	Zero Speed (frequency command)	Active when frequency command =0. (the drive should be at RUN mode)
6	Zero Speed with Stop (frequency command)	Active when frequency command =0 or stop.

7	Over Torque (OT1) (Pr.06-05~06-07)	Active when detecting over-torque. Refer to Pr.06-05 (over-torque detection selection-OT1), Pr.06-06 (over-torque detection level-OT1) and Pr.06-07 (over-torque detection time-OT1).
8	Over Torque (OT2) (Pr.06-08~06-10)	Active when detecting over-torque. Refer to Pr.06-08 (over-torque detection selection-OT2), Pr.06-09 (over-torque detection level-OT2) and Pr.06-10 (over-torque detection time-OT2).
9	Drive Ready	Active when the drive is ON and no abnormality detected.

10	User-defined Low-voltage Detection	Active when the DC Bus voltage is too low. (refer to Pr.06-00 low voltage level)
11	Malfunction Indication	Active when fault occurs (except Lv stop).
12	Mechanical Brake Release (Pr.02-29, Pr.02-30)	When drive runs after Pr.02-29, it will be ON. This function should be used with DC brake and it is recommended to use contact "b"(N.C).
13	Overheat (Pr.06-14)	Active when IGBT or heat sink overheats to prevent OH turn off the drive. (refer to Pr.06-14)
14	Brake Chopper Signal	The output will be activated when the drive needs help braking the load. A smooth deceleration is achieved by using this function. (refer to Pr.07-00)
15	Motor-controlled Magnetic Contactor Output	Active when the setting is set to 15.
16	Slip Error (oSL)	Active when the slip error is detected (by Pr.05-14).
17	Malfunction indication 1	Activate after 10ms when fault occurs (except Lv stop).
18	Reserved	
19	Brake Chopper Output Error	Active when the brake chopper error is detected
20	Warning Output	Active when the warning is detected.
21	Over-voltage Warning	Active when the over-voltage is detected.
22	Over-current Stall Prevention Warning	Active when the over-current stall prevention is detected.
23	Over-voltage Stall prevention Warning	Active when the over-voltage stall prevention is detected.
24	Operation Mode Indication	Active when the operation command is controlled by external terminal. (Pr.00-15=1) and PU LED on keypad KPVL-CC01 is OFF.
25	Forward Command	Active when the operation direction is forward.
26	Reverse Command	Active when the operation direction is reverse.
27	Output when Current \geq Pr.02-33	Active when current is \geq Pr.02-33.
28	Output when Current $<$ Pr.02-33	Active when current is $<$ Pr.02-33.
29	Output when frequency \geq Pr.02-34	Active when frequency is \geq Pr.02-34.
30	Output when Frequency $<$ Pr.02-34	Active when frequency is $<$ Pr.02-34.
31	Power Generation Direction and Status Verify	Activate when power generation direction is verified.
32	Power Generation Direction	Activate when power generation direction is forward run.
33	Zero Speed (actual output frequency)	Active when the actual output frequency is 0. (the drive should be at RUN mode)
34	Zero Speed with Stop (actual output frequency)	Active when the actual output frequency is 0 or Stop. (the drive should be at RUN mode)

35	Fault output option 1	Active when Pr.06-22 is ON.									
36	Fault output option 2	Active when Pr.06-23 is ON.									
37	Fault output option 3	Active when Pr.06-24 is ON.									
38	Fault output option 4	Active when Pr.06-25 is ON.									
39	Reserved										
40	Speed Attained (including zero speed)	Active when the output frequency reaches frequency setting.									
41	Reserved										
42	SO Logic Output A	<table border="1"> <tr> <td>Status of Drive</td> <td>Status of Safety Output</td> <td rowspan="4">Setting of Logic Output B is on pag 17-6</td> </tr> <tr> <td></td> <td>Status A (MO=42)</td> </tr> <tr> <td>Normal</td> <td>Broketrn Circuit(Open)</td> </tr> <tr> <td>STO</td> <td>Short Circuit(Close)</td> </tr> </table>	Status of Drive	Status of Safety Output	Setting of Logic Output B is on pag 17-6		Status A (MO=42)	Normal	Broketrn Circuit(Open)	STO	Short Circuit(Close)
		Status of Drive	Status of Safety Output	Setting of Logic Output B is on pag 17-6							
			Status A (MO=42)								
		Normal	Broketrn Circuit(Open)								
STO	Short Circuit(Close)										
STL1~STL3	Short Circuit(Close)										

02-23 Multi-output Direction

Control Mode **VF VFPG SVC FOC PG TQCPG FOC PM** Factory Setting:0
 Settings 0~65535

This parameter is bit setting. If the bit is 1, the multi-function output terminal will be act with opposite direction. For example, if Pr.02-11 is set to 1 and forward bit is 0, Relay 1 will be ON when the drive is running and OFF when the drive is stop.

Bit 11	Bit 10	Bit 9	Bit 8	Bit 7	Bit 6	Bit 5	Bit 4	Bit 3	Bit 2	Bit 1	Bit 0
-	-	-	-	-	-	MO2	MO1	R2A	R1A	MRA	RA

02-24 Serial Start Signal Selection

Control Mode **VF VFPG SVC FOC PG FOC PM** Factory Setting:0
 Settings 0: By FWD/REV signal
 1: By Enable signal

- This parameter is used to select serial start method of electromagnetic valve.
- When choose 0: by FWD/REV signal, the motor will start to run after the signal of enabling MI=40 is ON.
- When choose 1: by Enable signal, the electromagnetic valve, mechanical brake and DC brake will follow parameters' setting to run after FWD/REV and Enable are ON.

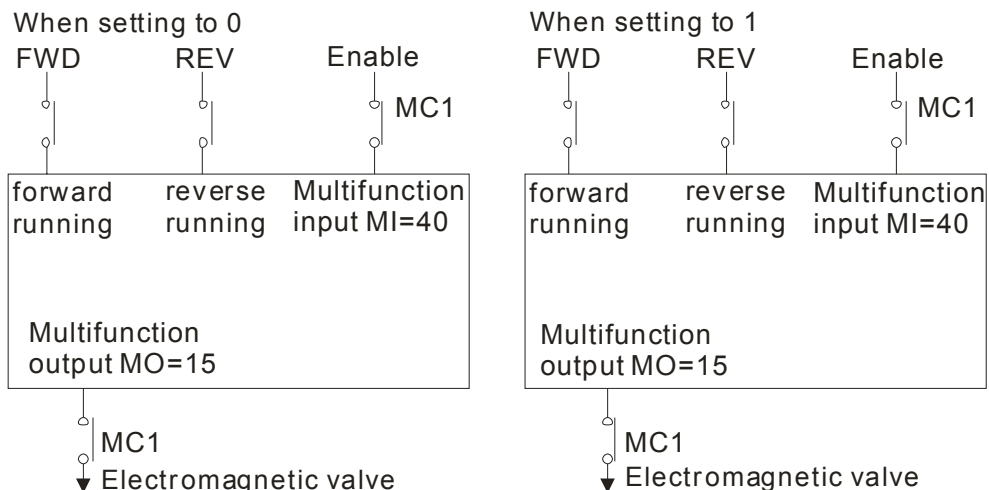

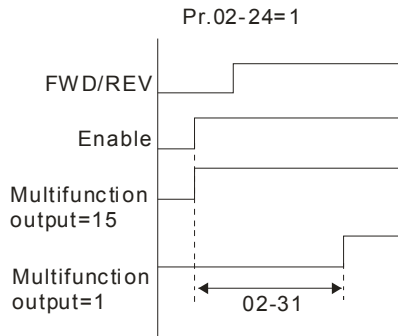
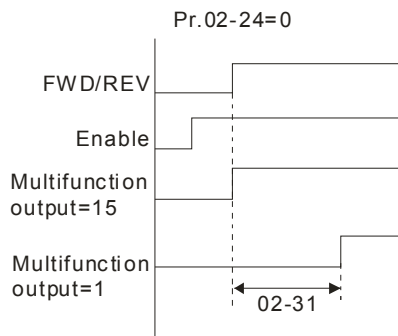

⚡ **02-25** Desired Frequency Attained 1
 Control Mode **VF VFPG SVC FOC PG FOC PM** Factory
 Setting:60.00/50.00
 Settings 0.00~400.00Hz

⚡ **02-26** The Width of the Desired Frequency Attained 1
 Control Mode **VF VFPG SVC FOC PG FOC PM** Factory Setting:2.00
 Settings 0.00~400.00Hz

⚡ **02-27** Desired Frequency Attained 2
 Control Mode **VF VFPG SVC FOC PG FOC PM** Factory
 Setting:60.00/50.00
 Settings 0.00~400.00Hz

⚡ **02-28** The Width of the Desired Frequency Attained 2
 Control Mode **VF VFPG SVC FOC PG FOC PM** Factory Setting:2.00
 Settings 0.00~400.00Hz

📖 Once the output frequency reaches desired frequency and the corresponding multi-function output terminal is set to 3 or 4 (Pr.02-11~Pr.02-22), this multi-function output terminal will be ON.

02-29 Brake Release Delay Time when Elevator Starts
 Control Mode **VF VFPG SVC FOC PG TQCPG FOC PM** Factory Setting:0.250
 Settings 0.000~65.000sec

02-30 Brake Engage Delay Time when Elevator Stops
 Control Mode **VF VFPG SVC FOC PG TQCPG FOC PM** Factory Setting:0.250
 Settings 0.000~65.000sec

📖 When the AC motor drive runs after the delay time set at Pr02-29, the corresponding multi-function output terminal (12: mechanical brake release) will be ON.

📖 When the AC motor drive stops and after Pr.02-30 delay time, the corresponding multi-function output terminal (12: mechanical brake release) will be OFF.

📖 This function needs to co-work with DC brake function.

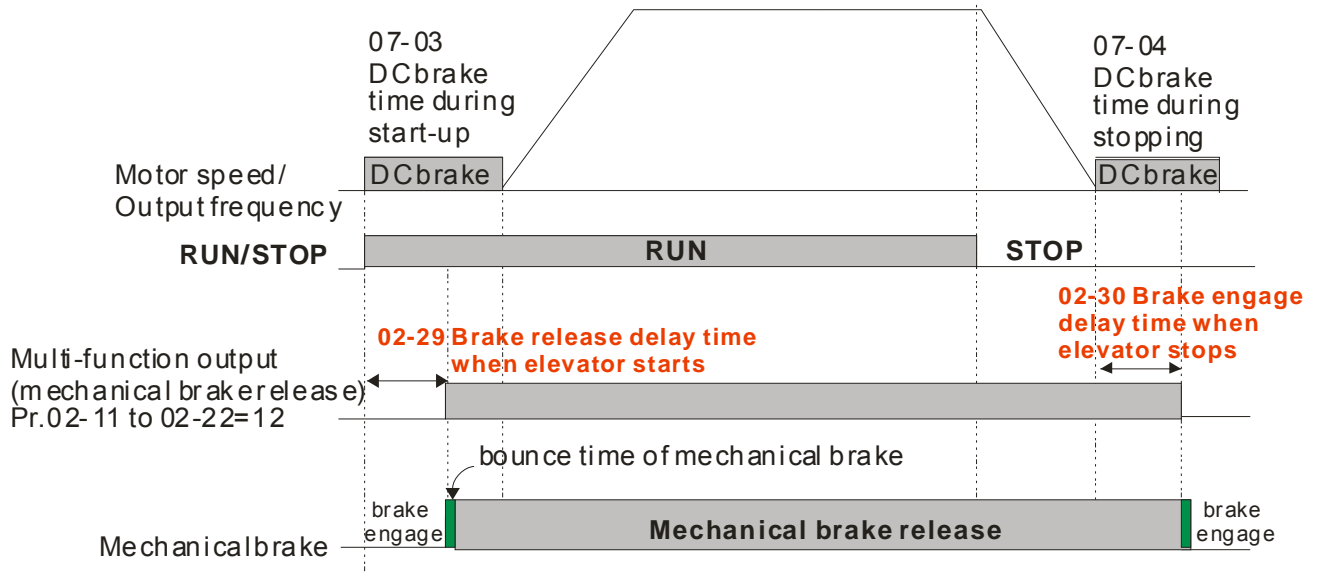

⚡ **02-31** Turn On Delay of Magnetic Contact between Drive and Motor

⚡ **02-32** Turn Off Delay of Magnetic Contact between Drive and Motor

Control Mode **VF VFPG SVC FOC PG TQCPG FOC PM**

Factory Setting:0.20

Settings 0.000~65.000sec

📖 After running, it is used with setting 40 of multifunction input terminal and settings 15 of multifunction output terminals. When multifunction output terminals is ON, the drive starts output after Pr.02-31 delay time. When drive stops output, multifunction output terminals will release after Pr.02-32 delay time.

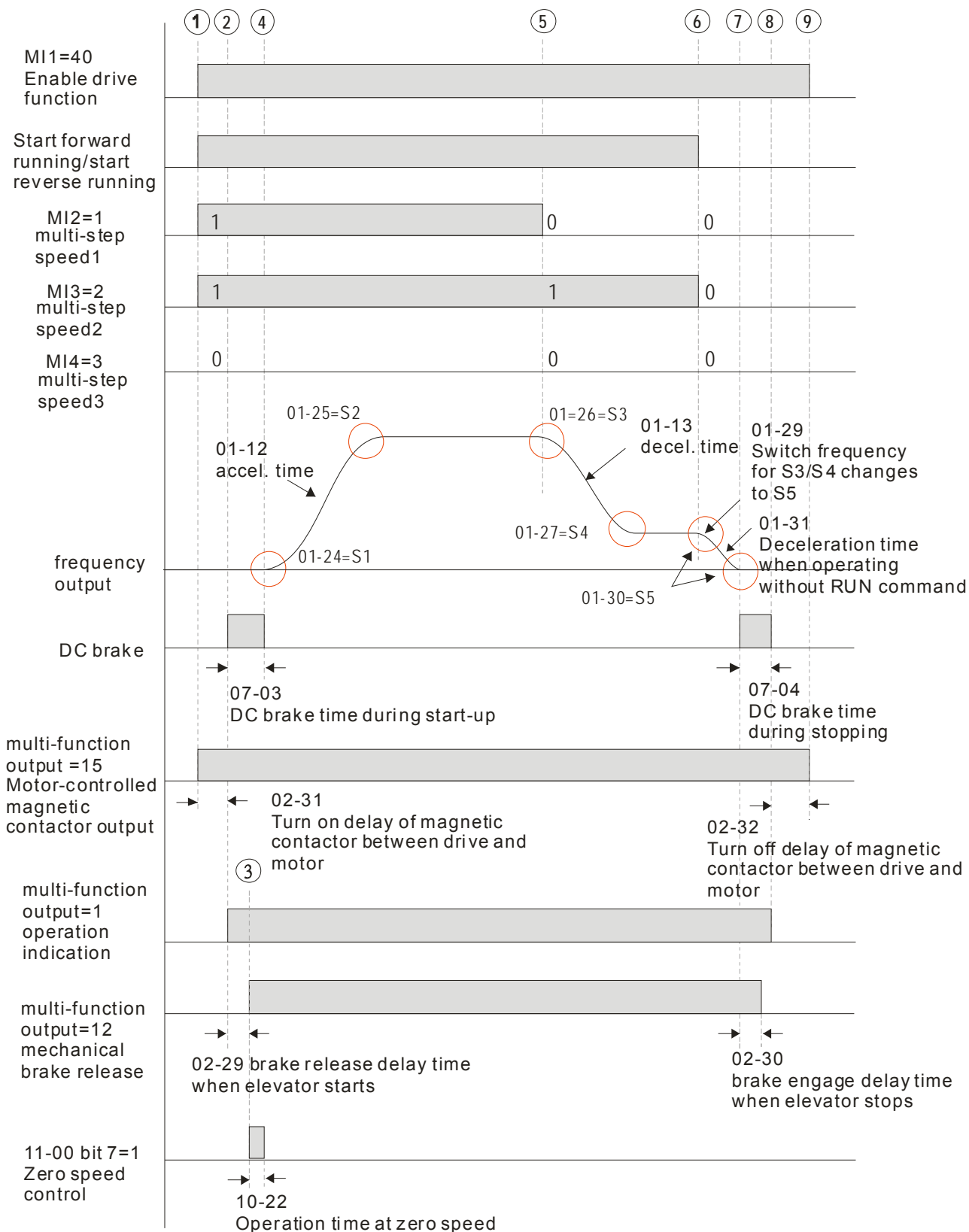

- ① elevator starts running ⑤ start deceleration ⑨ motor release
- ② electromagnetic valve is ON ⑥ the end of creep
- ③ brake release ⑦ start DC brake time during stopping
- ④ the end of DC brake time at start-up ⑧ the end of DC brake time during stopping

02-33 Output Current Level Setting for External Terminals

Control Mode **VF VFPG SVC FOC PG TQCPG FOC PM** Factory Setting:0
 Settings 0~100%

- When output current is \geq Pr.02-33, it will activate multi-function output terminal (Pr.02-11 to Pr.02-22 is set to 27).
- When output current is $<$ Pr.02-33, it will activate multi-function output terminal (Pr.02-11 to Pr.02-22 is set to 28).

02-34 Output Boundary for External Terminals

Control Mode **VF VFPG SVC FOC PG TQCPG FOC PM** Factory Setting:0.00
 Settings 0.00~ \pm 400.00Hz

- When output frequency is \geq 02-34, it will activate the multi-function terminal (Pr.02-11 to Pr.02-22 is set to 29).
- When output frequency is $<$ 02-34, it will activate the multi-function terminal (Pr.02-11 to Pr.02-22 is set to 30).

02-35 Detection Time of Mechanical Brake

Control Mode **VF VFPG SVC FOC PG TQCPG FOC PM** Factory Setting:0.00
 Settings 0.00~10.00sec

- When mechanical brake function (setting 42 of Pr.02-01~02-08) is not enabled within this setting time, it will display fault code 64 (MBF) mechanical brake error.

02-36 Detection Time of Magnetic Contactor

Control Mode **VF VFPG SVC FOC PG TQCPG FOC PM** Factory Setting:0.00
 Settings 0.00~10.00sec

- When mechanical brake function (setting 41 of Pr.02-01~02-08) is not enabled within this setting time, it will display fault code 66 (MCF) mechanical brake error.

02-37 Check Torque Output Function

Control Mode **VF VFPG SVC FOC PG TQCPG FOC PM** Factory Setting:0
 Settings 0: Enable
 1: Disable

- When the drive receives the operation signal, the drive will check if there is torque output. When this function is enabled, it will release mechanical brake after confirming that there is torque output.

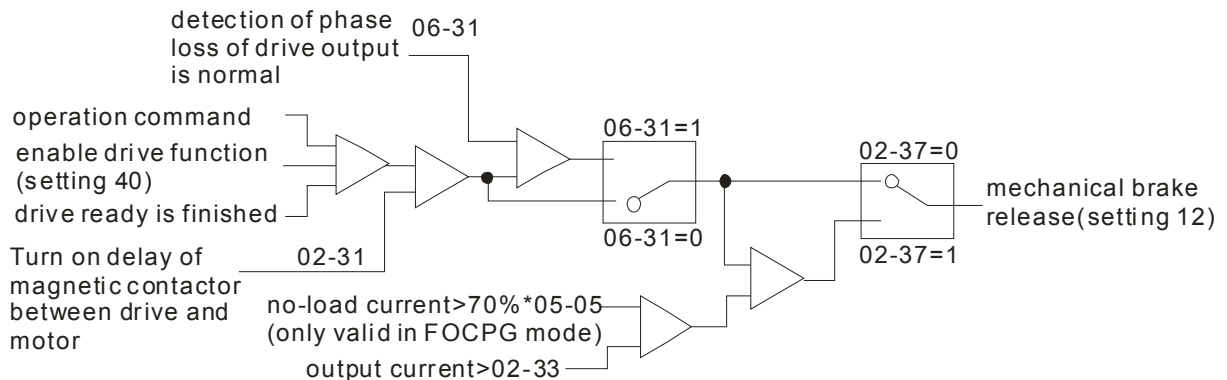

03 Analog Input/ Output Parameters

↘ **03-00** Analog Input 1 (AUI1)

Factory Setting:1

↘ **03-01** Reserved

↘ **03-02** Analog Input 2 (AUI2)

Factory Setting:0

Settings	Control Mode	VF	VFPG	SVC	FOCPG	TQCPG	FOCPM
0: No function		<input type="radio"/>	<input type="radio"/>	<input type="radio"/>	<input type="radio"/>	<input type="radio"/>	<input type="radio"/>
1: Frequency command (torque limit under TQR control mode)		<input type="radio"/>	<input type="radio"/>	<input type="radio"/>	<input type="radio"/>	<input type="radio"/>	<input type="radio"/>
2: Torque command (torque limit under speed mode)						<input type="radio"/>	
3: Preload input		<input type="radio"/>	<input type="radio"/>	<input type="radio"/>	<input type="radio"/>	<input type="radio"/>	<input type="radio"/>
4~5: Reserved							
6: P.T.C. thermistor input value		<input type="radio"/>	<input type="radio"/>	<input type="radio"/>	<input type="radio"/>	<input type="radio"/>	<input type="radio"/>
7: Positive torque limit					<input type="radio"/>		<input type="radio"/>
8: Negative torque limit					<input type="radio"/>		<input type="radio"/>
9: Regenerative torque limit					<input type="radio"/>		<input type="radio"/>
10: Positive/negative torque limit					<input type="radio"/>		<input type="radio"/>

- 📖 When it is frequency command or TQR speed limit, the corresponding value for 0~±10V/4~20mA is 0 – max. output frequency(Pr.01-00)
- 📖 When it is torque command or torque limit, the corresponding value for 0~±10V/4~20mA is 0 – max. output torque (Pr.07-14).
- 📖 When it is torque compensation, the corresponding value for 0~±10V/4~20mA is 0 – rated torque.

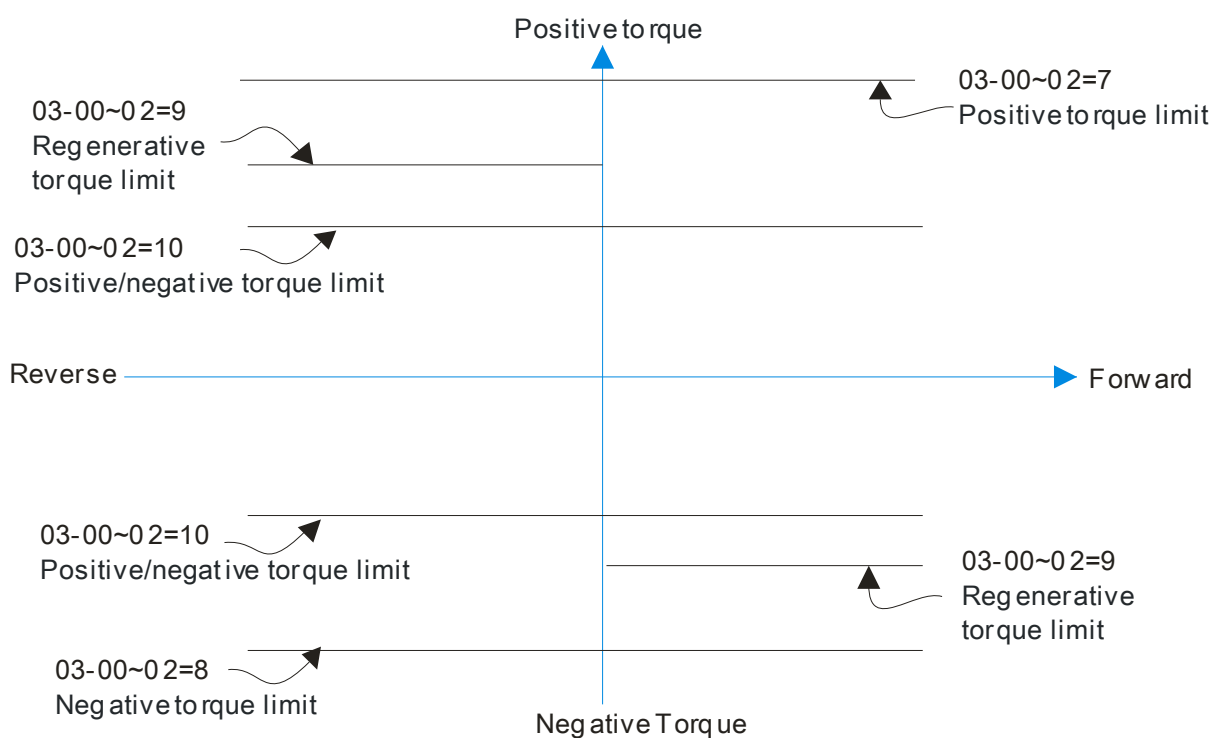

07-19: Source of torque offset
 03-00~02: Analog input selections (AUI1/ACI/AUI2)
 03-03~05: Analog input bias (AUI1/ACI/AUI2)
 03-06~08: AUI1/ACI/AUI2 bias mode

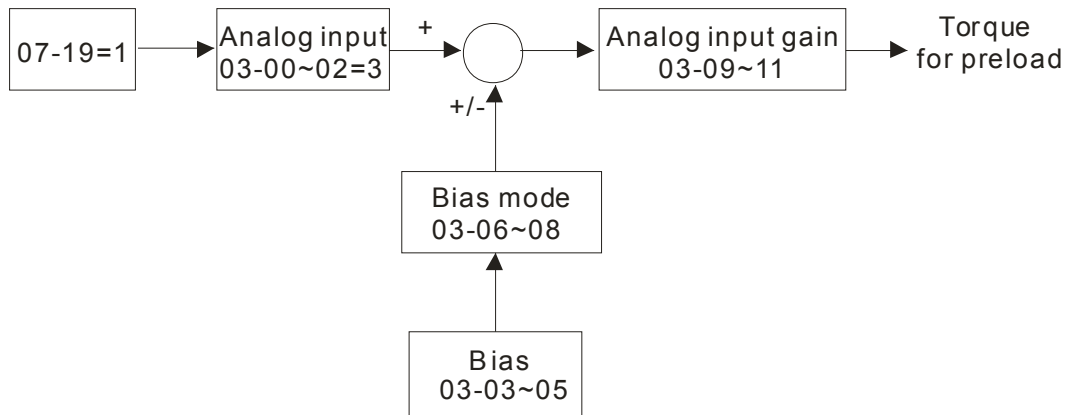

⚡ **03-03** Analog Input Bias 1 (AUI1)

Control Mode **VF** **VFP** **SVC** **FOCPG** **TQCPG** **FOCPM** Factory Setting:0.0

Settings -100.0~100.0%

📖 It is used to set the corresponding AUI1 voltage of the external analog input 0.

03-04 Reserved

⚡ **03-05** Analog Input Bias 1 (AUI2)

Control Mode **VF** **VFP** **SVC** **FOCPG** **TQCPG** **FOCPM** Factory Setting:0.0

Settings -100.0~100.0%

📖 It is used to set the corresponding AUI2 voltage of the external analog input 0.

📖 The relation between external input voltage/current and setting frequency is equal to -10~+10V (4-20mA) corresponds to 0-60Hz.

⚡ **03-06** AUI1 Positive/negative Bias Mode (AUI1)

Control Mode **VF** **VFP** **SVC** **FOCPG** **TQCPG** **FOCPM** Factory Setting:0

03-07 Reserved

⚡ **03-08** Positive/negative Bias Mode (AUI2)

Control Mode **VF** **VFP** **SVC** **FOCPG** **TQCPG** **FOCPM** Factory Setting:0

Settings 0: Zero bias

1: Serve bias as the center, lower than bias=bias

2: Serve bias as the center, greater than bias=bias

3: The absolute value of the bias voltage while serving as the center (unipolar)

4: Serve bias as the center (unipolar)

📖 In a noisy environment, it is advantageous to use negative bias to provide a noise margin. It is recommended NOT to use less than 1V to set the operating frequency.

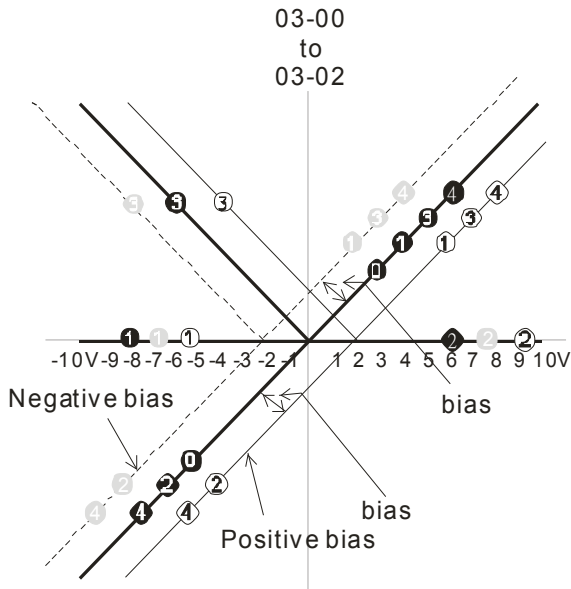

03-09~03-11 gain is positive

- 0 Zero bias
- 1 Serve bias as the center, lower than bias = bias
- 2 Serve bias as the center, greater than bias = bias
- 3 The absolute value of the bias voltage while serving as the center (unipolar)
- 4 Serve bias as the center (unipolar)

➤ **03-09** Analog Input Gain 1 (AUI1)
 Control Mode **VF** **VFP** **SVC** **FOCPG** **TQCPG** **FOCPM** Factory Setting:100.0
 Settings 0.0~500.0%

03-10 Reserved

➤ **03-11** Analog Input Gain 1 (AUI2)
 Control Mode **VF** **VFP** **SVC** **FOCPG** **TQCPG** **FOCPM** Factory Setting:100.0
 Settings 0.0~500.0%

📖 Parameters 03-03 to 03-11 are used when the source of frequency command is the analog voltage/current signal.

➤ **03-12** Analog Input Delay Time (AUI1)
 Control Mode **VF** **VFP** **SVC** **FOCPG** **TQCPG** **FOCPM** Factory Setting:0.01
 Settings 0.00~2.00sec

03-13 Reserved

➤ **03-14** analog Input Delay Time (AUI2)
 Control Mode **VF** **VFP** **SVC** **FOCPG** **TQCPG** **FOCPM** Factory Setting:0.01
 Settings 0.00~2.00sec

- 📖 Interferences commonly exist with analog signals, such as those entering AUI, ACI and AUI2. These interferences constantly affect the stability of analog control and using the Input Noise Filter will create a more stable system.
- 📖 If Pr03-14 is large, the control will be stable, yet the response to the input will be slow. If Pr. 03-14 is small, the control may be unstable, yet the response to the input will fast.

03-15 Reserved

03-16 Reserved

↗ **03-17** Analog Output Selection 1

↗ **03-20** Analog Output Selection 2

Control Mode **VF** **VFP** **SVC** **FOCPG** **TQCPG** **FOCPM** Factory Setting:0

Settings

- 0: Output frequency (Hz)
- 1: Frequency command (Hz)
- 2: Motor speed (RPM)
- 3: Output current (rms)
- 4: Output voltage
- 5: DC Bus Voltage
- 6: Power factor
- 7: Power
- 8: Output torque
- 9 : AUI1
- 10: Reserved
- 11: AUI2
- 12: q-axis current
- 13: q-axis feedback value
- 14: d-axis voltage
- 15: d-axi feedback value
- 16: q-axis voltage
- 17: d-axis voltage
- 18: Torque command
- 19~20: Reserved
- 21: Power output

↗ **03-18** Analog Output Gain 1

↗ **03-21** Analog Output Gain 2

Control Mode **VF** **VFP** **SVC** **FOCPG** **TQCPG** **FOCPM** Factory Setting:100.0

Settings 0~200.0%

 This parameter is set the corresponding voltage of the analog output 0.

↗ **03-19** Analog Output Value in REV Direction 1

↗ **03-22** Analog Output Value in REV Direction 2

Control Mode **VF** **VFP** **SVC** **FOCPG** **TQCPG** **FOCPM** Factory Setting:0

Settings

- 0: Absolute value in REV direction
- 1: Output 0V in REV direction
- 2: Enable output voltage in REV direction

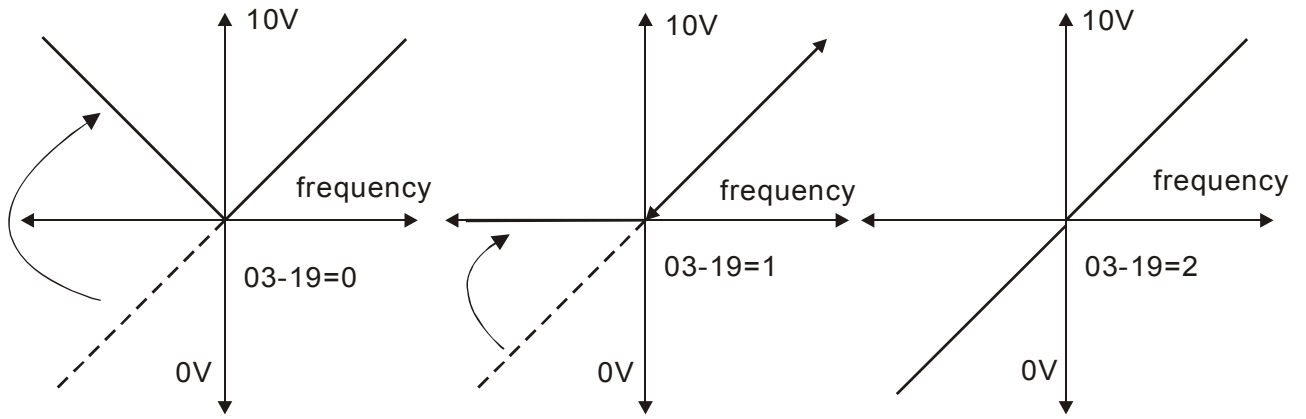

Selection for the analog output direction



03-23 Analog Input Type (AUI1)

03-24 Analog Input Type (AUI2)

Control Mode **VF** **VFP** **SVC** **FOCPG** **TQCPG** **FOCPM** Factory Setting:0

Settings 0: Bipolar ($\pm 10V$)

1: Unipolar (0~10V)

-  When setting to 0 and Pr.03-00=1 or 2, AUI can decide the operation direction.
-  When setting to 1 and Pr.03-00=1, the operation direction can be set by FWD/REV terminal.
-  When setting to 1 and Pr.03-00=2, the operation direction can be set by setting 39 of Pr.02-01 to Pr.02-08.

04 Multi-Step Speed Parameters

- ↘ **04-00** Zero Step Speed Frequency
- ↘ **04-01** 1st Step Speed Frequency
- ↘ **04-02** 2nd Step Speed Frequency
- ↘ **04-03** 3rd Step Speed Frequency
- ↘ **04-04** 4th Step Speed Frequency
- ↘ **04-05** 5th Step Speed Frequency
- ↘ **04-06** 6th Step Speed Frequency
- ↘ **04-07** 7th Step Speed Frequency
- ↘ **04-08** 8th Step Speed Frequency
- ↘ **04-09** 9th Step Speed Frequency
- ↘ **04-10** 10th Step Speed Frequency
- ↘ **04-11** 11th Step Speed Frequency
- ↘ **04-12** 12th Step Speed Frequency
- ↘ **04-13** 13th Step Speed Frequency
- ↘ **04-14** 14th Step Speed Frequency

Control Mode **VF** **VFPG** **SVC** **FOCPG** **FOCPM** Factory Setting:0.00
 Settings 0.00~120.00Hz

- ↘ **04-15** 15th Step Speed Frequency

Control Mode **VF** **VFPG** **SVC** **FOCPG** **FOCPM** Factory Setting:0.00
 Settings 0.00~400.00Hz

 The Multi-Function Input Terminals (refer to Pr.02-01 to 02-08) are used to select one of the AC motor drive Multi-step speeds(including the main speed, in total 16 speeds). The speeds (frequencies) are determined by Pr.04-00 to 04-15 as shown above.

05 IM Parameters

05-00 Motor Auto Tuning

Control Mode **VF**

Factory Setting:0

- Settings
- 0: No function
 - 1: Rolling test (Rs, Rr, Lm, Lx, no-load current)
 - 2: Static Test

📖 Starting auto tuning by pressing RUN key and it will write the measure value into Pr.05-05 to Pr.05-09 (Rs, Rr, Lm, Lx, no-load current).

📖 The steps to AUTO-Tuning are: (when setting to 1)

1. Make sure that all the parameters are set to factory settings and the motor wiring is correct.
2. Make sure the motor has no-load before executing auto-tuning and the shaft is not connected to any belt or gear motor. It is recommended to set to 2 if the motor can't separate from the load.
3. Fill in Pr.01-02, Pr.01-01, Pr.05-01, Pr.05-02, Pr.05-03 and Pr.05-04 with correct values. Refer to motor capacity to set accel./decel. time.
4. When Pr.05-00 is set to 1, the AC motor drive will execute auto-tuning immediately after receiving a "RUN" command. (NOTE: the motor will run!)
5. After executing, please check if all values are filled in Pr.05-05 to Pr.05-09.
6. Equivalent circuit

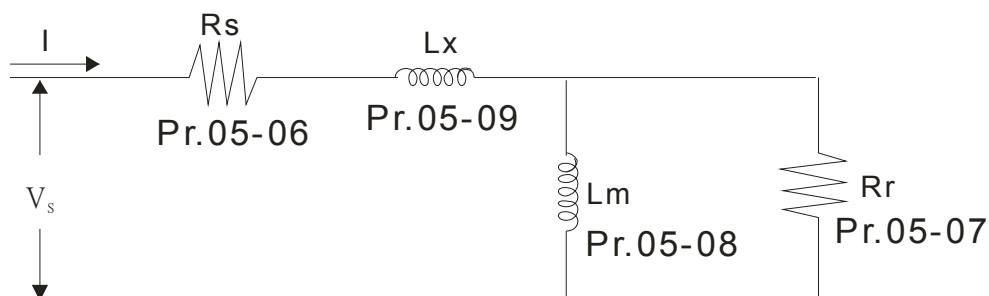

Equivalent circuit for VFD-ED Series

※ If Pr05-00 is set to <2: Static Test>, the input of Pr05-05 is required.

📖 NOTE

1. In torque/vector control mode, it is not recommended to have motors run in parallel.
2. It is not recommended to use torque/vector control mode if motor rated power exceeds the rated power of the AC motor drive.
3. The no-load current is usually 20~50% X rated current.
4. The rated speed can't be larger or equal to $120f/p$. (f : output frequency Pr.01-01, p : Number of Motor Poles Pr.05-04)
5. After the tuning, user needs to activate the drive again to make it operate if the source command of Auto-tuning comes from external terminal,

05-01 Full-load Current of MotorControl Mode **VF VFPG SVC FOCPG TQCPG**

Unit: Amp

Factory Setting:###

Settings (40~120%) *00-01 Amps



This value should be set according to the rated frequency of the motor as indicated on the motor nameplate. The factory setting is 90% X rated current.

Example: if the rated current for 7.5hp (5.5kW) models is 25A and the factory setting is 22.5A. In this way, the current range will be from 10A (25*40%) to 30A (25*120%).

05-02 Rated Power of MotorControl Mode **SVC FOCPG TQCPG**

Factory Setting:###

Settings 0.00~655.35 kW



It is used to set rated power of the motor. The factory setting is the power of the drive.

05-03 Rated Speed of Motor (rpm)Control Mode **VFPG SVC FOCPG TQCPG**

Factory Setting:1710

Settings 0~65535



It is used to set the rated speed of the motor and need to set according to the value indicated on the motor nameplate.

05-04 Number of Motor PolesControl Mode **VF VFPG SVC FOCPG TQCPG**

Factory Setting:4

Settings 2~48



It is used to set the number of motor poles (must be an even number).

05-05 No-load Current of MotorControl Mode **VFPG SVC FOCPG TQCPG**

單位：安培

Factory Setting:###

Settings 0~100%



The factory setting is 40% X rated current.

05-06 Rs of Motor**05-07** Rr of MotorControl Mode **SVC FOCPG TQCPG**

Factory Setting:0.000

Settings 0.000~65.535Ω

05-08 Lm of Motor**05-09** Lx of MotorControl Mode **SVC FOCPG TQCPG**

Factory Setting:0.0

Settings 0.0~6553.5mH

↗ **05-10** Torque Compensation Time ConstantControl Mode **SVC**

Factory Setting:0.020

Settings 0.001~10.000sec

- **05-11** Slip Compensation Time Constant
- | | | |
|--------------|-----------------|-----------------------|
| Control Mode | SVC | Factory Setting:0.100 |
| Settings | 0.001~10.000sec | |
-
- 📖 Setting Pr.05-10 and Pr.05-11 change the response time for the compensation.
 - 📖 When Pr.05-10 and Pr.05-11 are set to 10 seconds, its response time for the compensation will be the longest. But if the settings are too short, unstable system may occur.
- **05-12** Torque Compensation Gain
- | | | |
|--------------|----------------|-------------------|
| Control Mode | VF VFPG | Factory Setting:0 |
| Settings | 0~10 | |
-
- 📖 This parameter may be set so that the AC motor drive will increase its voltage output to obtain a higher torque.
- **05-13** Slip Compensation Gain
- | | | |
|--------------|--------------------|----------------------|
| Control Mode | VF VFPG SVC | Factory Setting:0.00 |
| Settings | 0.00~10.00 | |
-
- 📖 When the asynchronous motor is driven by the drive, the load and slip will be increased. This parameter can be used to correct frequency and lower the slip to make the motor can run near the synchronous speed under rated current. When the output current is larger than the motor no-load current, the drive will compensate the frequency by Pr.05-13 setting. If the actual speed is slower than expectation, please increase the setting and vice versa.
 - 📖 It is only valid in SVC mode.
- **05-14** Slip Deviation Level
- | | | |
|--------------|------------------------|-------------------|
| Control Mode | VFPG SVC FOC PG | Factory Setting:0 |
| Settings | 0~1000% | |
| | 0: Disable | |
-
- **05-15** Detection time of Slip Deviation
- | | | |
|--------------|------------------------|---------------------|
| Control Mode | VFPG SVC FOC PG | Factory Setting:1.0 |
| Settings | 0.0~10.0sec | |
-
- **05-16** Over Slip Treatment
- | | | |
|--------------|----------------------------|-------------------|
| Control Mode | VFPG SVC FOC PG | Factory Setting:0 |
| Settings | 0: Warn and keep operation | |
| | 1: Warn and ramp to stop | |
| | 2: Warn and coast to stop | |
-
- 📖 Pr.05-14 to Pr.05-16 are used to set allowable slip level/time and over slip treatment when the drive is running.
- **05-17** Hunting Gain
- | | | |
|--------------|--------------------|----------------------|
| Control Mode | VF VFPG SVC | Factory Setting:2000 |
| Settings | 0~10000 | |
| | 0: Disable | |
-
- 📖 The motor will have current wave motion in some specific area. It can improve this situation by setting this parameter. (When it is high frequency or run with PG, Pr.05-17 can be set to 0. when the current wave motion happens in the low frequency, please increase Pr.05-17.)

05-18 Accumulative Motor Operation Time (Min.)

Control Mode **VF VFPG SVC FOC PG TQCPG FOC PM** Factory Setting:00
 Settings 00~1439 minutes

05-19 Accumulative Motor Operation Time (Day)

Control Mode **VF VFPG SVC FOC PG TQCPG FOC PM** Factory Setting:00
 Settings 00~65535 days

 Pr. 05-18 and Pr.05-19 are used to record the motor operation time. They can be cleared by setting to 00 and time which is less than 60 seconds will not be recorded.

↗ **05-20** Core Loss Compensation

Control Mode **SVC** Factory Setting:10
 Settings 0~250%

05-21 Accumulative Drive Power-on Time (Min.)

Control Mode **VF VFPG SVC FOC PG TQCPG FOC PM** Factory Setting:00
 Settings 00~1439 minutes

05-22 Accumulative Drive Power-on Time (day)

Control Mode **VF VFPG SVC FOC PG TQCPG FOC PM** Factory Setting:00
 Settings 00~65535 days

06 Protection Parameters

06-00 Low Voltage Level

Control Mode **VF** **VFPG** **SVC** **FOCPG** **TQCPG** **FOCPM** Factory Setting:180.0/360.0

Settings 230V series: 160.0~220.0V
 460V series: 320.0~440.0V

It is used to set the Lv level.

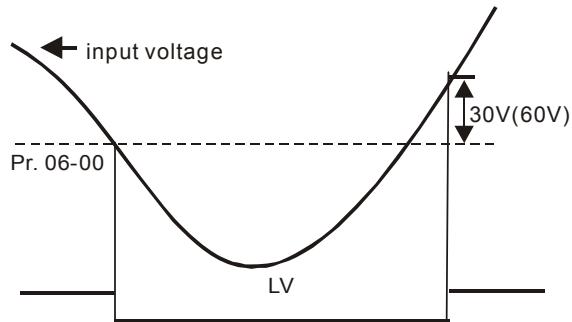

06-01 Phase-loss Protection

Control Mode **VF** **VFPG** **SVC** **FOCPG** **TQCPG** **FOCPM** Factory Setting:2

Settings 0: Error and keep operation
 1: Error and ramp to stop
 2: Error and coast to stop

It is used to set the phase-loss treatment. The phase-loss will effect driver's control characteristic and life

06-02 Over-Current Stall Prevention during Acceleration

Control Mode **VF** **VFPG** **SVC** Factory Setting:00

Settings 00: Disable
 00~250%

During acceleration, the AC drive output current may increase abruptly and exceed the value specified by Pr.06-02 due to rapid acceleration or excessive load on the motor. When this function is enabled, the AC drive will stop accelerating and keep the output frequency constant until the current drops below the maximum value.

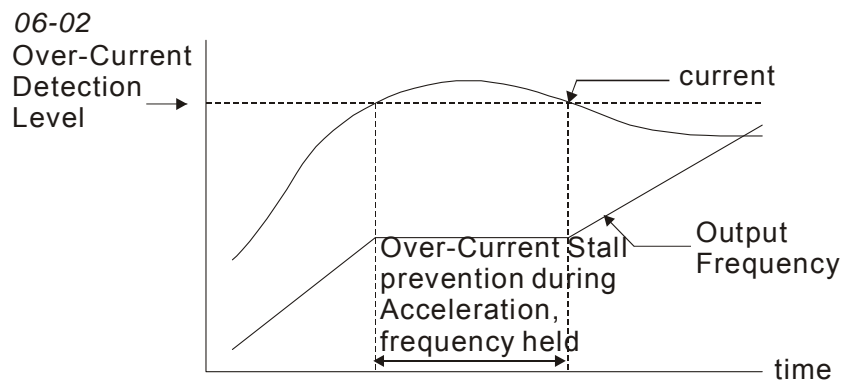

actual acceleration time when over-current stall prevention is enabled

06-03 Over-current Stall Prevention during Operation

Control Mode **VF** **VFP** **SVC**

Factory Setting:00

Settings 00: Disable
00~250%

If the output current exceeds the setting specified in Pr.06-03 when the drive is operating, the drive will decrease its output frequency by Pr.06-04 setting to prevent the motor stall. If the output current is lower than the setting specified in Pr.06-03, the drive will accelerate (by Pr.06-04) again to catch up with the set frequency command value.

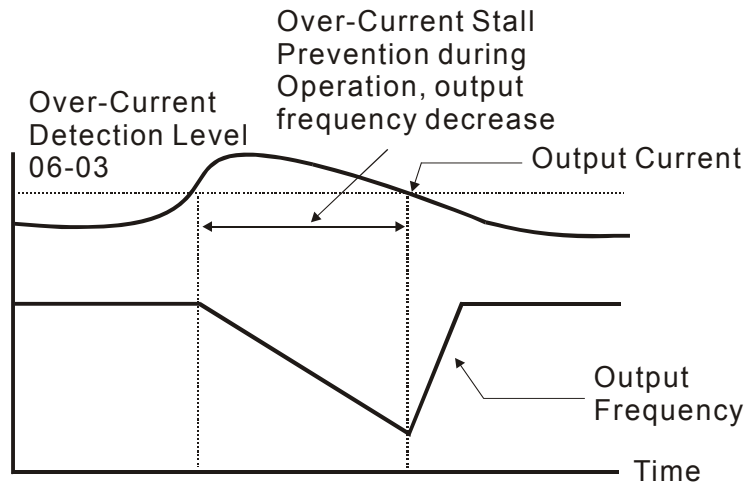

over-current stall prevention during operation

06-04 Accel./Decel. Time Selection of Stall Prevention at constant speed

Control Mode **VF** **VFP** **SVC**

Factory Setting:0

Settings 0: current accel/decel time
1: the 1st accel/decel time
2: the 2nd accel/decel time
3: the 3rd accel/decel time
4: the 4th accel/decel time
5: auto accel/decel time

It is used to set the accel./decel. time selection when stall prevention occurs at constant speed.

06-05 Over-torque Detection Selection (OT1)

Control Mode **VF** **VFP** **SVC** **FOCPG** **TQCPG** **FOCPM**

Factory Setting:0

Settings 0: Over-Torque detection disabled.
1: Over-torque detection during constant speed operation, continue to operate after detection
2: Over-torque detection during constant speed operation, stop operation after detection
3: Over-torque detection during operation, continue to operate after detection
4: Over-torque detection during operation, stop operation after detection

↗	06-06	Over-torque Detection Level (OT1)						
	Control Mode	VF	VFPG	SVC	FOCPG	TQCPG	FOCPM	Factory Setting:150
	Settings	10~250%						
↗	06-07	Over-torque Detection Time (OT1)						
	Control Mode	VF	VFPG	SVC	FOCPG	TQCPG	FOCPM	Factory Setting:0.1
	Settings	0.0~60.0sec						
↗	06-08	Over-torque Detection Selection (OT2)						
	Control Mode	VF	VFPG	SVC	FOCPG	TQCPG	FOCPM	Factory Setting:0
	Settings	0: Over-Torque detection disabled. 1: Over-torque detection during constant speed operation, continue to operate after detection 2: Over-torque detection during constant speed operation, stop operation after detection 3: Over-torque detection during operation, continue to operate after detection 4: Over-torque detection during operation, stop operation after detection						
↗	06-09	Over-torque Detection Level (OT2)						
	Control Mode	VF	VFPG	SVC	FOCPG	TQCPG	FOCPM	Factory Setting:150
	Settings	10~250%						
↗	06-10	Over-torque Detection Time (OT2)						
	Control Mode	VF	VFPG	SVC	FOCPG	TQCPG	FOCPM	Factory Setting:0.1
	Settings	0.0~60.0sec						

📖 Pr.06-05 and Pr.06-08 determine the operation mode of the drive after the over-torque is detected via the following method: if the output current exceeds the over-torque detection level (Pr.06-06) and also exceeds the Pr.06-07 Over-Torque Detection Time, the fault code “OT1/OT2” is displayed. If a Multi-Functional Output Terminal is to over-torque detection, the output is on. Please refer to Pr.02-11~02-22 for details.

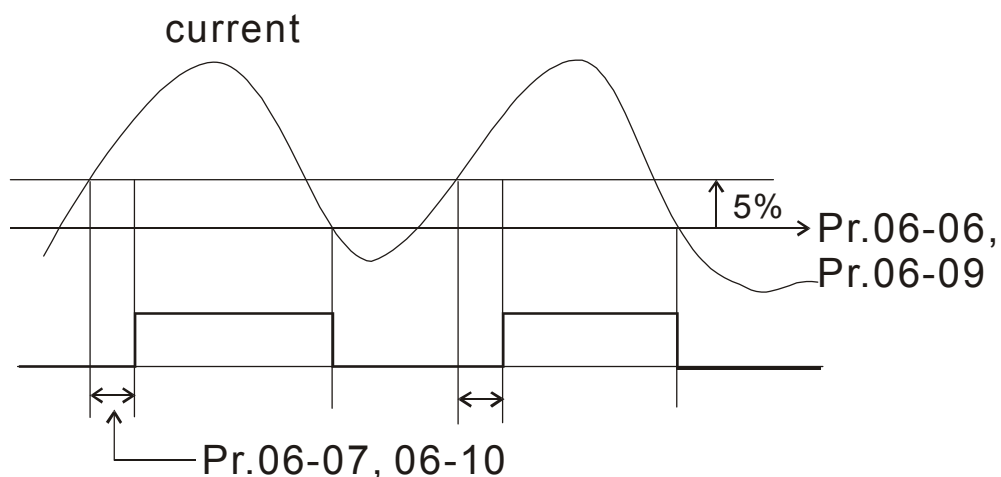

↗	06-11	Current Limit				
	Control Mode		FOCPG	TQCPG	FOCPM	Factory Setting:200
	Settings	0~250%				

📖 It is used to set the current limit.

06-12 Electronic Thermal Relay Selection

Control Mode **VF VFPG SVC FOC PG TQCPG FOC PM** Factory Setting:2

- Settings 0: Inverter motor
 1: Standard motor
 2: Disabled

It is used to prevent self-cooled motor overheats under low speed. User can use electrical thermal relay to limit driver's output power.

06-13 Electronic Thermal Characteristic

Control Mode **VF VFPG SVC FOC PG TQCPG FOC PM** Factory Setting:60.0

Settings 30.0~600.0sec

The parameter is set by the output frequency, current and operation time of the drive for activating the I²t electronic thermal protection function. The function will be activated for the 150% * setting current for the setting of Pr.06-13.

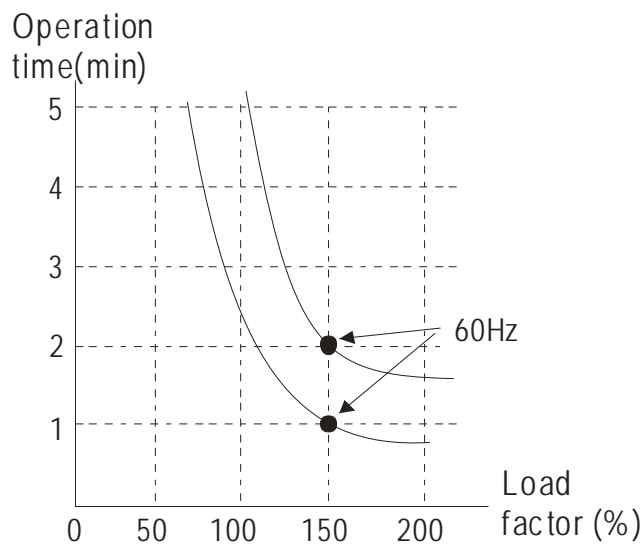

06-14 Heat Sink Over-heat (OH) Warning

Control Mode **VF VFPG SVC FOC PG TQCPG FOC PM** Factory Setting:85.0

Settings 0.0~110.0°C

06-15 Stall Prevention Limit Level

Control Mode **VF VFPG SVC** Factory Setting:50

Settings 0~100% (Refer to Pr06-02, Pr06-03)

When the operating frequency is larger than Pr.01-01, Pr06-02=150%, Pr. 06-03=100% and Pr. 06-15=80%:

Stall Prevention Level during acceleration = 06-02x06-15=150x80%=120%.

Stall Prevention Level at constant speed= 06-03x06-15=100x80%=80%.

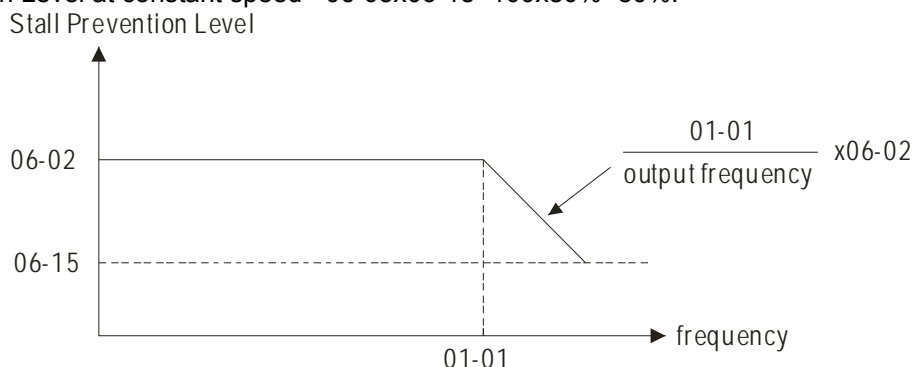

06-16	Present Fault Record
06-17	Second Most Recent Fault Record
06-18	Third Most Recent Fault Record
06-19	Fourth Recent Fault Record
06-20	Fifth Most Recent Fault Record
06-21	Sixth Most Recent Fault Record

Control mode	VF	VFPG	SVC	FOCPG	TQCPG	FOCPM	Factory setting: 0
Readings		0		No fault			
		1		Over-current during acceleration (ocA)			
		2		Over-current during deceleration (ocd)			
		3		Over-current during constant speed (ocn)			
		4		Ground fault (GFF)			
		5		IGBT short-circuit (occ)			
		6		Over-current at stop (ocS)			
		7		Over-voltage during acceleration (ovA)			
		8		Over-voltage during deceleration (ovd)			
		9		Over-voltage during constant speed (ovn)			
		10		Over-voltage at stop (ovS)			
		11		Low-voltage during acceleration (LvA)			
		12		Low-voltage during deceleration (Lvd)			
		13		Low-voltage during constant speed (Lvn)			
		14		Low-voltage at stop (LvS)			
		15		Phase loss (PHL)			
		16		IGBT heat sink over-heat (oH1)			
		17		Heat sink over-heat (oH2)(for 40HP above)			
		18		TH1 open loop error (tH1o)			
		19		TH2 open loop error (tH2o)			
		20		Fan error signal output			
		21		Over-load (oL) (150% 1Min)			
		22		Motor over-load (EoL1)			
		23		Reserved			
		24		Motor PTC overheat (oH3)			
		25		Reserved			
		26		Over-torque 1 (ot1)			
		27		Over-torque 1 (ot2)			
		28		Reserved			
		29		Reserved			
		30		Memory write-in error (cF1)			
		31		Memory read-out error (cF2)			
		32		Isum current detection error (cd0)			
		33		U-phase current detection error (cd1)			
		34		V-phase current detection error (cd2)			
		35		W-phase current detection error (cd3)			
		36		Clamp current detection error (Hd0)			

37	Over-current detection error (Hd1)
38	Over-voltage detection error (Hd2)
39	Ground current detection error (Hd3)
40	Auto tuning error (AuE)
41	PID feedback loss (AFE)
42	PG feedback error (PGF1)
43	PG feedback loss (PGF2)
44	PG feedback stall (PGF3)
45	PG slip error (PGF4)
46	PG ref input error (PGr1)
47	PG ref loss (PGr2)
48	Analog current input error (ACE)
49	External fault input (EF)
50	Emergency stop (EF1)
51	Reserved
52	Password error (PcodE)
53	Reserved
54	Communication error (cE1)
55	Communication error (cE2)
56	Communication error (cE3)
57	Communication error (cE4)
58	Communication Time-out (cE10)
59	PU time-out (cP10)
60	Brake chopper error (bF)
61-62	Reserved
63	Safety loop error (Sry)
64	Mechanical brake error (MBF)
65	PGF5 hardware error
66	Magnetic contactor error (MCF)
67	Phase loss of drive output (MPHL)
68	CAN Bus disconnected
69	Safety Torque Off(STO)
70	Channel 1(STo1~SCM1), abnormal safety circuit
71	Channel 2(STO2~SCM2) abnormal safety circuit
72	Abnormal internal circuit

 It will record when the fault occurs and force stopping. For the Lv, it will record when it is operation, or it will warn without record.

06-30 Setting Method of Fault Output

Control Mode **VF** **VFP** **SVC** **FOCPG** **TQCPG** **FOCPM**

Factory Setting:0

Settings 0: By settings of Pr.06-22~06-25

1: By the binary setting

It is used with the settings 35~38 of Pr.02-11~02-22 (Multi-function Output). The fault output selection 1~4 corresponds to Bit 0~3.

This parameter provides two setting methods for the fault output. Setting 0: it is set by the settings of Pr.06-22~Pr.06-25; setting 1: it is set by the binary setting and please refer to the following example for details.

Example:

Assume that

Pr.02-13 (Multi-function Output 3 R1A (Relay3)) is set to 35 Fault output option 1 (Pr.06-22).

Pr.02-14 (Multi-function Output 4 R2A (Relay4)) is set to 36 Fault output option 2 (Pr.06-23).

Pr.02-15 (Multi-function Output 5 (MO1)) is set to 37 Fault output option 3 (Pr.06-24).

Pr.02-16 (Multi-function Output 6 (MO2)) is set to 38 Fault output option 4 (Pr.06-25).

Assume that external faults output with the following signal: R1A=1, R2A=1, MO1=0 and MO2=1. The corresponding Bit 3~0 is 1011.

Bit 3	Bit 2	Bit 1	Bit 0	Fault code
-	-	-	-	0: No fault
0	0	0	1	1: Over-current during acceleration (ocA)
				2: Over-current during deceleration (ocd)
				3: Over-current during constant speed (ocn)
				4: Ground fault (GFF)
				5: IGBT short-circuit (occ)
				6: Over-current at stop (ocS)
0	0	1	0	7: Over-voltage during acceleration (ovA)
				8: Over-voltage during deceleration (ovd)
				9: Over-voltage during constant speed (ovn)
				10: Over-voltage at stop (ovS)
0	0	1	1	11: Low-voltage during acceleration (LvA)
				12: Low-voltage during deceleration (Lvd)
				13: Low-voltage during constant speed (Lvn)
				14: Low-voltage at stop (LvS)
				15: Phase loss (PHL)
0	1	0	0	16: IGBT heat sink over-heat (oH1)
				17: Heat sink over-heat (oH2)(for 40HP above)
				18: TH1 open loop error (tH1o)
				19: TH2 open loop error (tH2o)
1	0	0	0	20: Fan error signal output
0	1	0	1	21: over-load (oL) (150% 1Min)
0	1	1	0	22: Motor 1 over-load (EoL1)
				24: Motor PTC overheat (oH3)
0	1	1	1	26: over-torque 1 (ot1)
				27: over-torque 1 (ot2)
1	0	0	0	30: Memory write-in error (cF1)
				31: Memory read-out error (cF2)
				32: Isum current detection error (cd0)
				33: U-phase current detection error (cd1)
				34: V-phase current detection error (cd2)
				35: W-phase current detection error (cd3)
				36: Clamp current detection error (Hd0)
				37: Over-current detection error (Hd1)
				38: Over-voltage detection error (Hd2)
				39: Ground current detection error (Hd3)

Bit 3	Bit 2	Bit 1	Bit 0	Fault code
1	0	0	1	40: Auto tuning error (AuE)
1	0	1	0	41: PID feedback loss (AFE)
				42: PG feedback error (PGF1)
				43: PG feedback loss (PGF2)
0	1	1	1	44: PG feedback stall (PGF3)
1	0	1	0	45: PG slip error (PGF4)
				46: PG ref input error (PGr1)
				47: PG ref loss (PGr2)
				48: Analog current input error (ACE)
1	0	1	1	49: External fault input (EF)
1	0	0	1	50: Emergency stop (EF1)
1	0	0	1	52: Password error (PcodE)
1	1	0	0	54: Communication error (cE1)
				55: Communication error (cE2)
				56: Communication error (cE3)
				57: Communication error (cE4)
				58: Communication Time-out (cE10)
				59: PU time-out (cP10)
1	0	0	0	60: Brake chopper error (bF)
1	0	1	1	63: Safety loop error (Sry)
				64: Mechanical brake error (MBF)
1	0	0	0	65: PGF5 hardware error
1	0	1	1	66: Magnetic contactor error (MCF)
1	0	1	1	67: Phase loss of drive output (MPHL)
1	1	0	1	68: CAN Bus disconnected
1	1	1	0	69: Safety Torque Off (STO)
1	1	1	0	70: Channel 1(STO1~SCM1) abnormal safety circuit
1	1	1	0	71: Channel 2(STO2~SCM2) abnormal safety circuit
1	1	1	0	72: Abnormal internal circuit

- ↗ **06-22** Fault Output Option 1
- ↗ **06-23** Fault Output Option 2
- ↗ **06-24** Fault Output Option 3
- ↗ **06-25** Fault Output Option 4

Control Mode **VF VFPG SVC FOC PG TQCPG FOC PM**

Factory Setting:0

Settings 0~6553 sec (refer to bit table for fault code)

📖 These parameters can be used with multi-function output (set Pr.02-11 to Pr.02-22 to 35-38) for the specific requirement. When a fault occurs, the corresponding terminals will be activated (It needs to convert binary value to decimal value to fill in Pr.06-22 to Pr.06-25).

Fault code	Bit0	Bit1	Bit2	Bit3	Bit4	Bit5	Bit6
	current	Volt.	OL	SYS	FBK	EXI	CE
0: No fault							
1: Over-current during acceleration (ocA)	●						
2: Over-current during deceleration (ocd)	●						
3: Over-current during constant speed (ocn)	●						
4: Ground fault (GFF)						●	
5: IGBT short-circuit (occ)	●						
6: Over-current at stop (ocS)	●						
7: Over-voltage during acceleration (ovA)		●					
8: Over-voltage during deceleration (ovd)		●					
9: Over-voltage during constant speed (ovn)		●					
10: Over-voltage at stop (ovS)		●					
11: Low-voltage during acceleration (LvA)		●					
12: Low-voltage during deceleration (Lvd)		●					
13: Low-voltage during constant speed (Lvn)		●					
14: Low-voltage at stop (LvS)		●					
15: Phase loss (PHL)						●	
16: IGBT heat sink over-heat (oH1)			●				
17: Heat sink over-heat (oH2)(for 40HP above)			●				
18: TH1 open loop error (tH1o)			●				
19: TH2 open loop error (tH2o)			●				
20: Fan error signal output						●	
21: over-load (oL) (150% 1Min)			●				
22: Motor 1 over-load (EoL1)			●				
23: Reserved							
24: Motor PTC overheat (oH3)			●				
25: Reserved							
26: over-torque 1 (ot1)			●				
27: over-torque 1 (ot2)			●				

Fault code	Bit0	Bit1	Bit2	Bit3	Bit4	Bit5	Bit6
	current	Volt.	OL	SYS	FBK	EXI	CE
28: Reserved							
29: Reserved							
30: Memory write-in error (cF1)				●			
31: Memory read-out error (cF2)				●			
32: Isum current detection error (cd0)				●			
33: U-phase current detection error (cd1)				●			
34: V-phase current detection error (cd2)				●			
35: W-phase current detection error (cd3)				●			
36: Clamp current detection error (Hd0)				●			
37: Over-current detection error (Hd1)				●			
38: Over-voltage detection error (Hd2)				●			
39: Ground current detection error (Hd3)				●			
40: Auto tuning error (AuE)				●			
41: PID feedback loss (AFE)					●		
42: PG feedback error (PGF1)					●		
43: PG feedback loss (PGF2)					●		
44: PG feedback stall (PGF3)					●		
45: PG slip error (PGF4)					●		
46: PG ref input error (PGr1)					●		
47: PG ref loss (PGr2)						●	
48: Analog current input error (ACE)						●	
49: External fault input (EF)						●	
50: Emergency stop (EF1)						●	
51: Reserved							
52: Password error (PcodE)				●			
53: Reserved							
54: Communication error (cE1)							●
55: Communication error (cE2)							●
56: Communication error (cE3)							●
57: Communication error (cE4)							●
58: Communication Time-out (cE10)							●
59: PU time-out (cP10)							●
60: Brake chopper error (bF)						●	
61-62: Reserved							
63: Safety loop error (Sry)				●			
64: Mechanical brake error (MBF)						●	
65: PGF5 hardware error				●			
66: Magnetic contactor error (MCF)						●	
67: Phase loss of drive output (MPHL)						●	
68: CAN Bus disconnected							●
69: Safety Torque Off (STO)				●			●

Fault code	Bit0	Bit1	Bit2	Bit3	Bit4	Bit5	Bit6
	current	Volt.	OL	SYS	FBK	EXI	CE
70: Channel 1(STO1~SCM1) abnormal safety circuit				●			
71: Channel 2(STO2~SCM2) abnormal safety circuit				●			
72: Abnormal internal circuit				●			

06-26 PTC (Positive Temperature Coefficient) Detection Selection

Control Mode **VF** **VFP** **SVC** **FOCPG** **TQCPG** **FOCPM** Factory Setting:0
 Settings 0: Warn and keep operating
 1: Warn and ramp to stop

This parameter is to set the treatment after detecting PTC.

06-27 PTC Level

Control Mode **VF** **VFP** **SVC** **FOCPG** **TQCPG** **FOCPM** Factory Setting:50.0
 Settings 0.0~100.0%

This parameter is to set the PTC level. The corresponding value of 100% PTC level is the max. analog input value.

06-28 PTC Filter Time for PTC Detection

Control Mode **VF** **VFP** **SVC** **FOCPG** **TQCPG** **FOCPM** Factory Setting:0.20
 Settings 0.00~10.00sec

06-29 Voltage of Emergency Power

Control Mode **VF** **VFP** **SVC** **FOCPG** **TQCPG** **FOCPM** Factory Setting:48.0/96.0
 Settings 48.0~375.0Vdc
 96.0~750.0Vdc

This parameter needs to work with setting #43 <EPS function> of Pr02-01 ~ Pr02-08<Multi-function input command>.

06-31 Phase Loss Detection of Drive Output at Start-Up(MPHL)

Control Mode **VF** **VFP** **SVC** **FOCPG** **TQCPG** **FOCPM** Factory Setting:0
 Settings 0: Disable
 1: Enable

When it is set to 1, it will auto detect if the connection between the drive and motor is normal whenever the drive runs. If errors occur to the connection between the drive and the motor, the drive will display fault code "67" to indicate motor output phase loss.

06-32 Accumulative Drive Power-on Time at the First Fault (min.)

06-34 Accumulative Drive Power-on Time at the Second Fault (min.)

06-36 Accumulative Drive Power-on Time at the Third Fault (min.)

06-38 Accumulative Drive Power-on Time at the Fourth Fault (min.)

06-40 Accumulative Drive Power-on Time at the Fifth Fault (min.)

06-42 Accumulative Drive Power-on Time at the Sixth Fault (min.)

Control Mode **VF** **VFP** **SVC** **FOCPG** **TQCPG** Factory Setting:00
 Settings 00~1439 min

06-33	Accumulative Drive Power-on Time at the First Fault (day)
06-35	Accumulative Drive Power-on Time at the Sceond Fault (day)
06-37	Accumulative Drive Power-on Time at the Third Fault (day)
06-39	Accumulative Drive Power-on Time at the Fourth Fault (day)
06-41	Accumulative Drive Power-on Time at the Fifth Fault (day)
06-43	Accumulative Drive Power-on Time at the Sixth Fault (day)

Control Mode **VF VFPG SVC FOC PG TQCPG** Factory Setting:00
 Settings 00~65535 day

↗ **06-44** Operation Speed of Emergency Power Mode

Control Mode **VF VFPG SVC FOC PG TQCPG FOC PM** Factory Setting: Read Only
 Settings 0.00~400.00Hz

↗ **06-45** Low-voltage Protection

Control Mode **VF VFPG SVC FOC PG TQCPG FOC PM** Factory Setting:0
 Settings 0: Display Lv fault and coast to stop
 1: Display Lv warn and coast to stop
 2: Fan lock, fault and coast to stop
 3: Fan lock, warn and coast to stop

↗ **06-46** Operation Direction for Emergency Power ON

Control Mode **VF VFPG SVC FOC PG TQCPG FOC PM** Factory Setting:1
 Settings 0 Operate by current command
 1 Operate by the direction of power generating mode
 2 After determining the direction of power generating, the host computer sends the operating direction command. (When at STOP mode determine the direction of power generating mode (MO =32) but do not retain the direction of the power generating.)
 3 After determining the direction of power generating, the host computer send the operating direction command. (When at STOP mode, determine the direction of power generating mode (MO =32) and retain the direction of the power generating.)

- 📖 Pr.06-46 is enabled when the external terminal is detecting for the emergency power.
- 📖 When Pr.06-46 is set to 1 and a forward/reverse run command is given, the drive will begin to detect for the elevator loading and operates in the power regeneration direction (the motor is in power generating status). The drive will use and operate in the direction that was detected as its power regeneration

direction. The drive will not operate in user command direction for safety purpose, to prevent voltage drop of emergency power.

VF and SVC control mode: within the time setting of Pr.06-47, the drive detects the elevator loading status by performing forward/reverse run. Then the elevator operates in power regeneration direction (the motor id in power generating status). Refer to the diagram below for the Auto-Detection Time Graph.

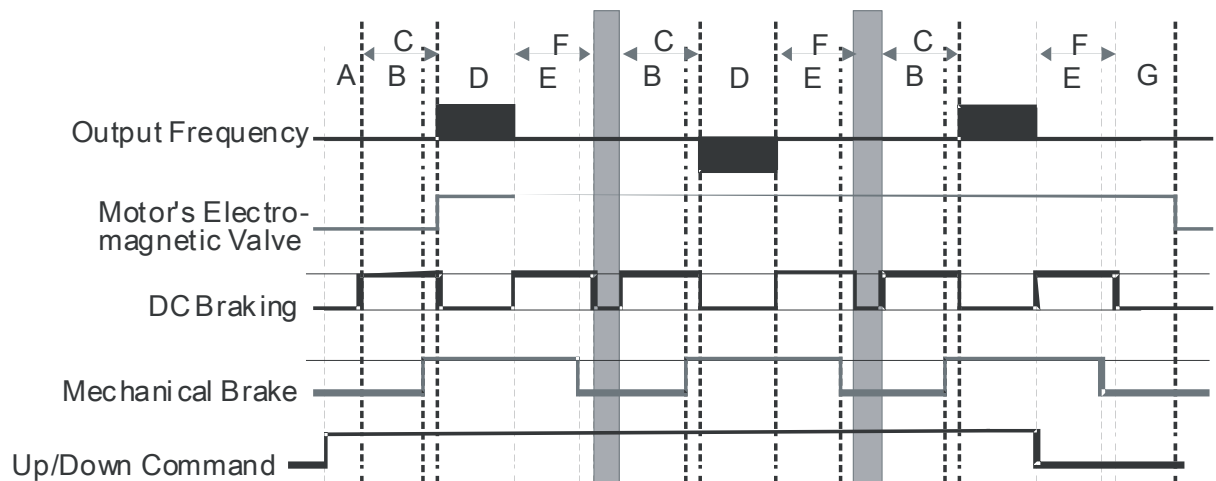
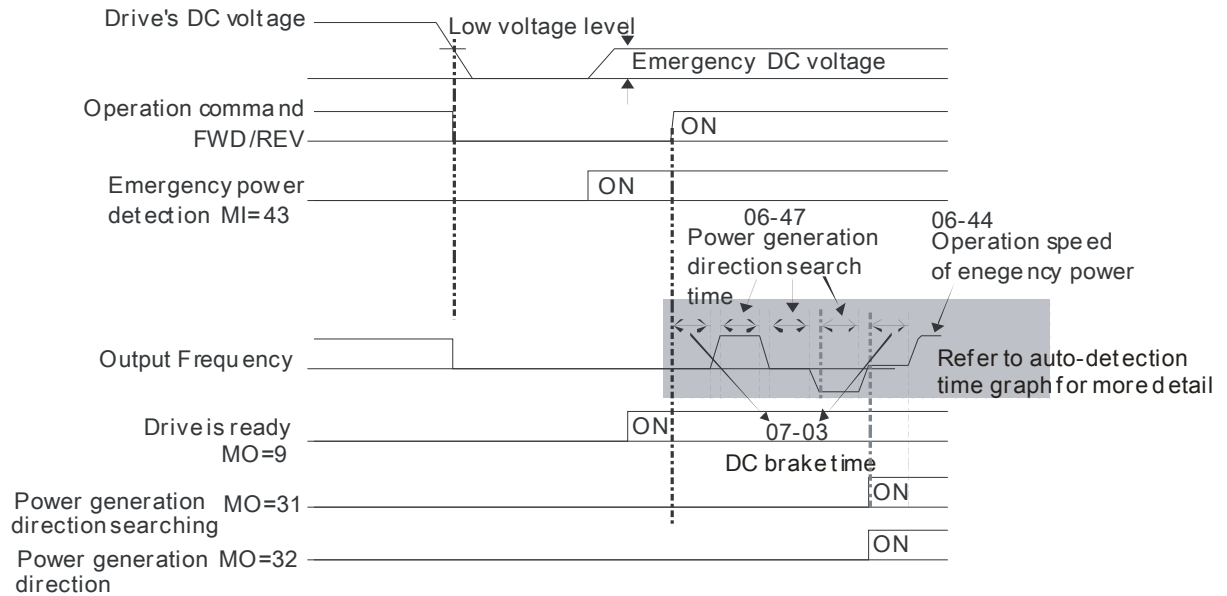

- | | |
|--|---|
| A 02-31: Turn On Delay of Magnetic Contactor between Drive and Motor | E 02-30: Brake Engage Delay Time when Elevator Stops |
| B 02-29: Brake Release Delay Time when Elevator Starts | F 07-04: Require DC Brake Time to Stop |
| C 07-03: DC Brake Activation Time | G 02-32: Turn Off Delay of Magnetic Contactor between Drive and Motor |
| D 06-47: Power Generation Direction Searching Time | |

Auto-detection Time Graph

FOCPG/PM Control Mode: within the time setting of Pr.06-47, the drive maintains at zero-speed and it is able to determine the elevator loading without performing forward/reverse run. Then the elevator operates in power regeneration direction (the motor is in power generating status). Refer to the diagram below for the Auto-Detection Time Graph.

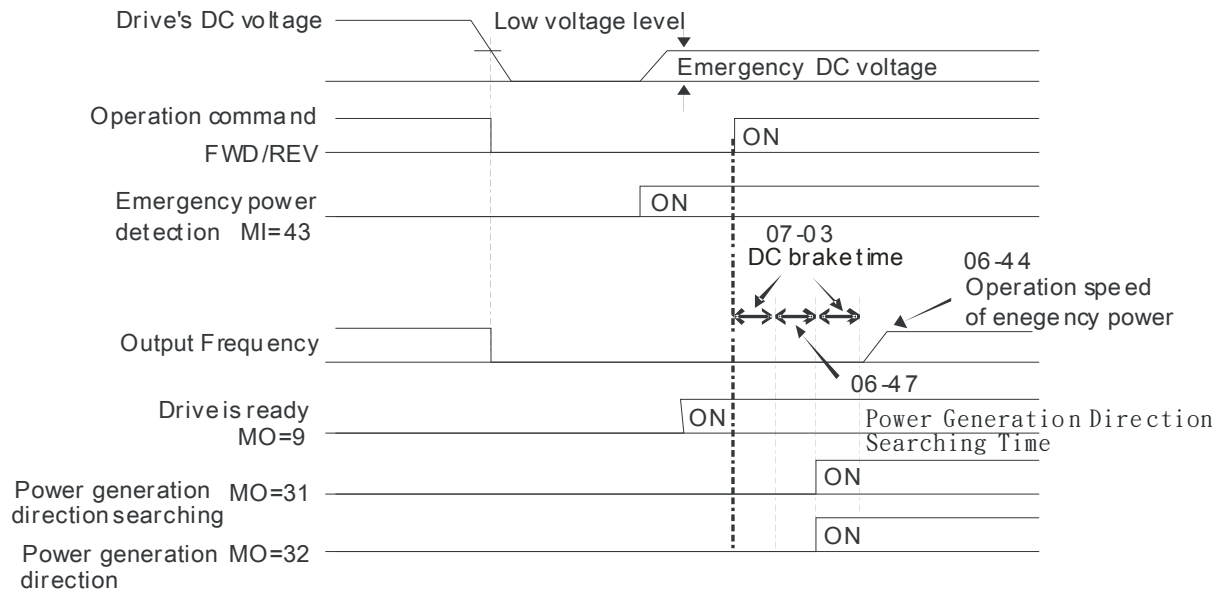

06-47 Power Generation Direction Searching Time
 Control Mode **VF VFPG SVC FOC PG TQCPG FOC PM** Factory Setting:1.0
 Settings 0.0 ~ 5.0sec

06-48 Power Capacity of Emergency Power
 Control Mode **VF VFPG SVC FOC PG TQCPG FOC PM** Factory Setting:0.0
 Settings 0.0 ~ 100.0 kVA

When using emergency power, user must input the required power capacity for the emergency power and then the AC drive will calculate the acceptable elevator speed (Pr.06-44) by following equation.



$$V_{eps_max} = \frac{06-48 \times 0.5}{\sqrt{3} \times I_{motor_rated}}$$

$$f_{eps_limit} = \frac{V_{eps_max}}{01-02} \times 01-01 \times 0.5$$

$$I_{motor_rated} = 05-01 \text{ (Induction Motor)} / 08-01 \text{ (PM Motor)}$$

- When Frequency Command > fEPS, the operation speed of emergency power is fEPS.
- When Frequency Command ≤ fEPS, the operation speed of emergency power is set by current frequency command.

06-49 STO Latch Selection
 Control Mode **VF VFPG SVC FOC PG TQCPG FOC PM** Factory Setting:0
 Settings 0: STO alarm Latch
 1: STO alarm no Latch

- Pr06-44=0 STO Alarm Latch: after the reason of STO Alarm is cleared, a Reset command is need to clear STO Alarm.
- Pr06-44=1 STO Alarm no Latch: after the reason of STO Alarm is cleared, the STO Alarm will be cleared automatically.
- All of STL1~STL3 error are "Alarm latch" mode (in STL1~STL3 mode, the Pr06-44 function is no effective).

07 Special Parameters

07-00 Brake Chopper Level

Control Mode **VF** **VFPG** **SVC** **FOCPG** **TQCPG** **FOCPM** Factory Setting:380.0/760.0
 Settings 230V series: 350.0~450.0Vdc
 460Vseries: 700.0~900.0Vdc

This parameter sets the DC-bus voltage at which the brake chopper is activated.

07-01 Reserved

07-02 DC Brake Current Level

Control Mode **VF** **VFPG** **SVC** Factory Setting:0
 Settings 0~100%

This parameter sets the level of DC Brake Current output to the motor during start-up and stopping. When setting DC Brake Current, the Rated Current (Pr.00-01) is regarded as 100%. It is recommended to start with a low DC Brake Current Level and then increase until proper holding torque has been attained.

When it is in FOCPG/TQCPG/FOCPM mode, it can enable DC brake function by setting to any value.

07-03 啟動直流制動時間 DC Brake Activation Time

Control Mode **VF** **VFPG** **SVC** **FOCPG** **FOCPM** Factory Setting:0.0
 Settings 0.0~60.0sec

This parameter sets the duration of DC Brake current is supplied to motor when activating the drive.

07-04 DC Brake Stopping Time

Control Mode **VF** **VFPG** **SVC** **FOCPG** **FOCPM** Factory Setting:0.0
 Settings 0.0~60.0sec

This parameter sets the duration of DC Brake current is supplied to motor when stopping the drive.

07-05 Start-Point for DC Brake

Control Mode **VF** **VFPG** **SVC** **FOCPG** Factory Setting:0.00
 Settings 0.00~400.00Hz

This parameter determines the frequency when DC Brake will begin during deceleration. When the setting is less than start frequency (Pr.01-09), start-point for DC brake will begin from the min. frequency.

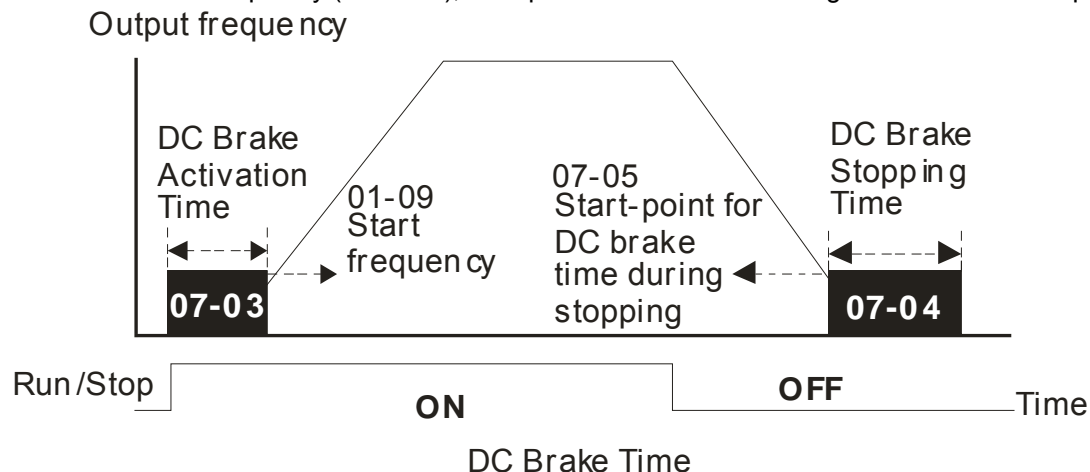

↗ **07-06** DC Brake Proportional Gain
 Control Mode **VF VFPG SVC** Factory Setting:50
 Settings 1~500

📖 It is used to set the output voltage gain when DC brake.

↗ **07-07** Dwell Time at Accel.
 Control Mode **VF VFPG SVC FOC PG FOC PM** Factory Setting:0.00
 Settings 0.00~600.00sec

↗ **07-09** Dwell Time at Decel.
 Control Mode **VF VFPG SVC FOC PG FOC PM** Factory Setting:0.00
 Settings 0.00~600.00sec

↗ **07-08** Dwell Frequency at Accel.
 Control Mode **VF VFPG SVC FOC PG FOC PM** Factory Setting:0.00
 Settings 0.00~400.00Hz

↗ **07-10** Dwell Frequency at Decel.
 Control Mode **VF VFPG SVC FOC PG FOC PM** Factory Setting:0.00
 Settings 0.00~400.00 Hz

📖 In the heavy load situation, Dwell can make stable output frequency temporarily.

📖 Pr.07-07 to Pr.07-10 are for heavy load to prevent OV or OC occurs.

Frequency

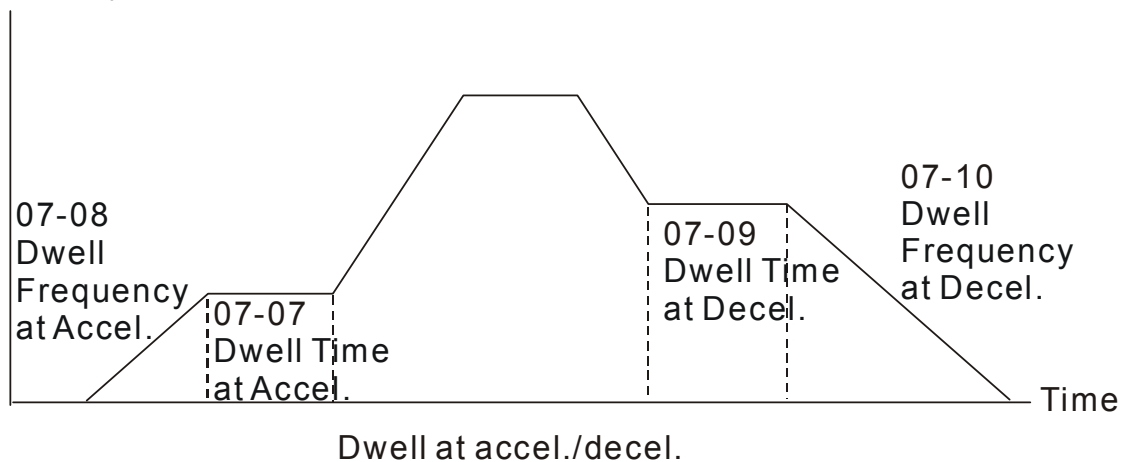

↗ **07-11** Fan Control
 Control Mode **VF VFPG SVC FOC PG TQCPG FOC PM** Factory Setting:2
 Settings 0: Fan always ON

1: 1 minute after AC motor drive stops, fan will be OFF

2: AC motor drive runs and fan ON, AC motor drive stops and fan OFF

3: Fan ON to run when preliminary heat sink temperature attained

4: Fan always OFF

📖 This parameter is used for the fan control.

📖 When setting to 3, fan will start to run until temperature is less than 40°C if temperature exceeds 40°C.

➤ **07-12** Torque Command

Control Mode **TQCPG** Factory Setting:0.0
 Settings -100.0 to 100.0% (Pr. 07-14 setting=100%)

📖 This parameter is torque command. When Pr.07-14 is 250% and Pr.07-12 is 100%, the actual torque command = 250X100% X motor rated torque.

➤ **07-13** Torque Command Source

Control Mode **TQCPG** Factory Setting:2
 Settings 0: KPC-CC01 Digital keypad
 1: RS485 serial communication
 2: Analog signal (Pr.03-00)

📖 This parameter is torque command source and the torque command is in Pr.07-12

➤ **07-14** Maximum Torque Command

Control Mode **VF VFPG SVC FOC PG TQCPG FOC PM** Factory Setting:100
 Settings 0~300%

📖 This parameter is for the max. torque command (motor rated torque is 100%).

➤ **07-15** Filter Time of Torque Command

Control Mode **TQCPG** Factory Setting:0.000
 Settings 0.000~1.000sec

📖 When the setting is too long, the control will be stable but the control response will be delay. When the setting is too short, the response will be quickly but the control maybe unstable. User can adjust the setting by the control and response situation.

07-16 Speed Limit Selection

Control Mode **TQCPG** Factory Setting:0
 Settings 0: By Pr.07-17 and Pr.07-18
 1: Frequency command source (Pr.00-14)

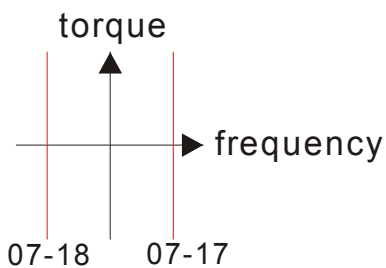

Pr.07-16=0
 Running/opposite running direction are limited by Pr.07-17 and Pr.07-18.

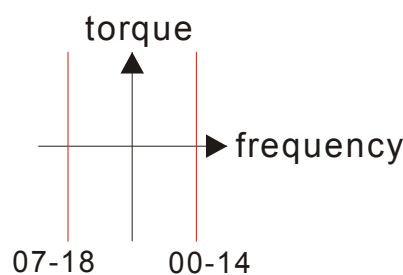

Pr.07-16=1
 When it is forward running, running direction is limited by Pr.00-14
 opposite running direction is limited by Pr.07-18.

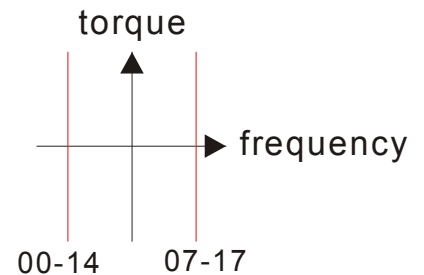

Pr.07-16=1
 When it is reverse running, running direction is limited by Pr.07-17
 opposite running direction is limited by Pr.00-14.

↗ **07-17** Torque Mode+Speed Limit
 Control Mode **TQCPG** Factory Setting:10
 Settings 0~120%

↗ **07-18** Torque Mode-Speed Limit
 Control Mode **TQCPG** Factory Setting:10
 Settings 0~120%

📖 These parameters are used in the torque mode to limit the running direction and opposite direction.
 (Pr.01-00 max. output frequency=100%)

↗ **07-19** Source of Torque Offset
 Control Mode **SVC FOC PG TQCPG FOC PM** Factory Setting:0
 Settings 0: Disable
 1: Analog input (Pr.03-00)
 2: Torque offset setting (Pr.07-20)
 3: Control by external terminal (by Pr.07-21 to Pr.07-23)

📖 This parameter is the source of torque offset.

📖 When it is set to 3, the source of torque offset will decide to Pr.07-21, Pr.07-22 and Pr.07-23 by the multi-function input terminals setting (31, 32 or 33).

02-01~02-08 is set to31	02-01~02-08 is set to32	02-01~02-08 is set to 33	Torque offset
OFF	OFF	OFF	N/A
OFF	OFF	ON	07-23
OFF	ON	OFF	07-22
OFF	ON	ON	07-23+07-22
ON	OFF	OFF	07-21
ON	OFF	ON	07-21+07-23
ON	ON	OFF	07-21+07-22
ON	ON	ON	07-21+07-22+07-23

↗ **07-20** Torque Offset Setting
 Control Mode **SVC FOC PG TQCPG FOC PM** Factory Setting:0.0
 Settings 0.0~100.0%

📖 This parameter is torque offset. The motor rated torque is 100%.

↗ **07-21** High Torque Offset
 Control Mode **SVC FOC PG TQCPG FOC PM** Factory Setting:30.0
 Settings 0.0~100.0%

↗ **07-22** Middle Torque Offset
 Control Mode **SVC FOC PG TQCPG FOC PM** Factory Setting:20.0
 Settings 0.0~100.0%

↗ **07-23** Low Torque Offset
 Control Mode **SVC FOC PG TQCPG FOC PM** Factory Setting:10.0
 Settings 0.0~100.0%

📖 When it is set to 3, the source of torque offset will decide to Pr.07-21, Pr.07-22 and Pr.07-23 by the multi-function input terminals setting (19, 20 or 21). The motor rated torque is 100%.

- ↗ **07-24** Forward Motor Torque Limit
- ↗ **07-25** Forward Regenerative Torque Limit
- ↗ **07-26** Reverse Motor Torque Limit
- ↗ **07-27** Reverse Regenerative Torque Limit

Control Mode **FOCPG TQCPG FOCPM** Factory Setting:200

Settings 0~300%

- 📖 The motor rated torque is 100%. The settings for Pr.07-24 to Pr.07-27 will compare with Pr.03-00=5, 6, 7, 8. The minimum of the comparison result will be torque limit.
- 📖 The motor rated torque is 100%. The settings for Pr.07-24 to Pr.07-27 will compare with Pr.03-00=5, 6, 7, 8. The minimum of the comparison result will be torque limit.

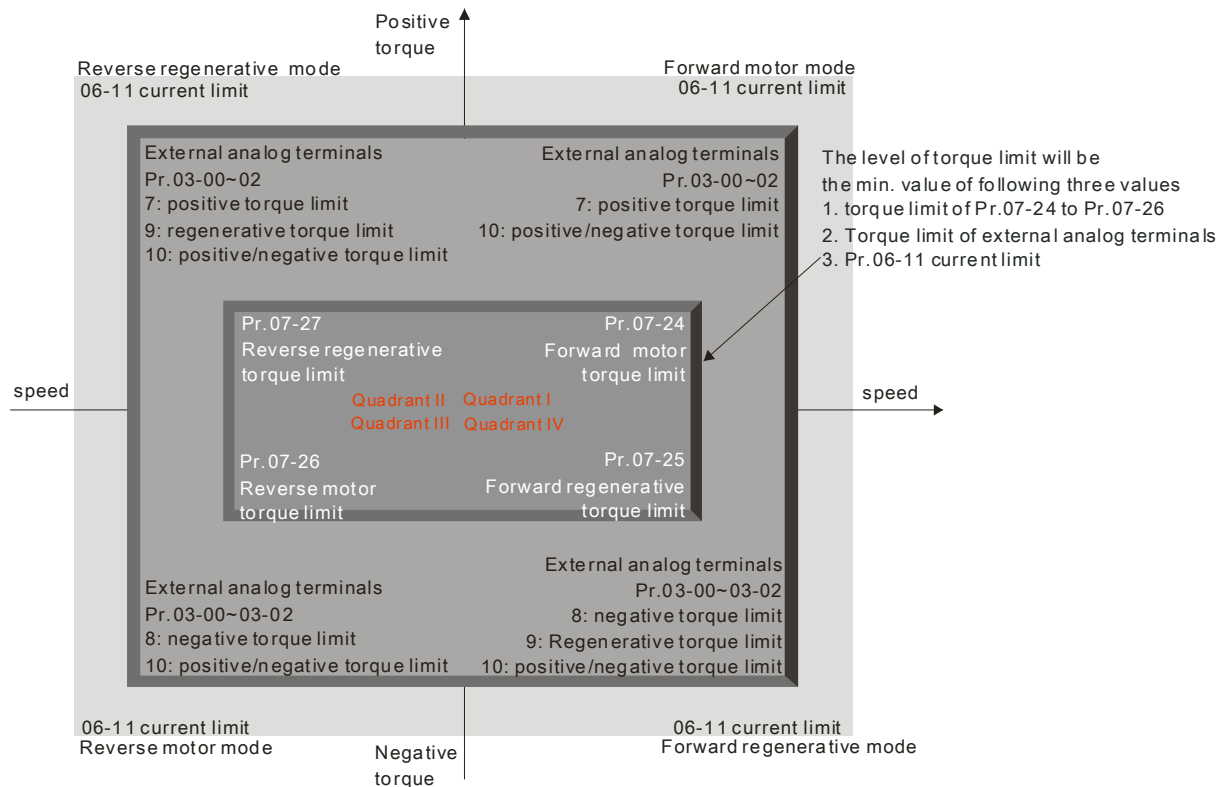

↗ **07-28** Emergency Stop (EF) & Forced Stop Selection

Control Mode **VF VFPG SVC FOC PG TQCPG FOC PM** Factory Setting:0

- Settings 0: Coast to stop
- 1 : By deceleration Time 1
 - 2 : By deceleration Time 2
 - 3 : By deceleration Time 3
 - 4 : By deceleration Time 4
 - 5 : By Pr.01-31

- 📖 When the multi-function input terminal is set to 10 or 14 and it is ON, the AC motor drive will be operated by Pr.07-28.

↗ **07-29** Time for Decreasing Torque at Stop

Control Mode **FOCPG TQCP G FOC M** Factory Setting:0.000

Settings 0.000~1.000sec

- When the elevator is stop and the mechanical brake is engaged, the drive will stop output. At the same time, it will produce the noise from the reacting force between the motor and the mechanical brake. This parameter can be used to decrease this reacting force and lower the noise.
- It is used to set the time for decreasing torque to 0%.

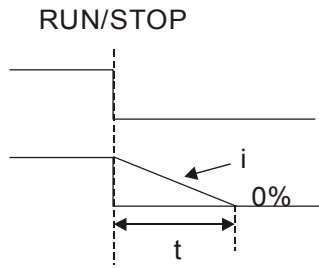

$$\frac{i}{100-0} \times \frac{100\%}{300\%} \times (07-29) = t$$

08 PM Parameters

Motor Auto Tuning

Control Mode

FOCPM

Factory Setting:0

Settings 0: No function

1: Only for the unloaded motor, auto measure the angle between magnetic pole and PG origin (08-09)

2: For PM parameters (brake locked)

3: Auto measure the angle between magnetic pole and PG origin (08-09)

For setting 1: It can auto measure the angle between magnetic pole and PG origin. Follow the steps below when measuring:

1. Unload before tuning
2. If brake is controlled by drive, the drive will act by the normal operation to finish tuning after wiring and setting brake control parameter
3. brake is controlled by drive, the drive will act by the normal operation to finish tuning after wiring and setting brake control parameter

For setting 3: It can auto measure the angle between magnetic pole and PG origin. Follow the steps below when measuring:

1. It can be loaded motor or unloaded motor before tuning
2. If brake is controlled by drive, the drive will act by the normal operation to finish tuning after wiring and setting brake control parameters
3. If brake is controlled by the host controller, it needs to make sure that brake is in release state before tuning
4. Make sure the setting of Pr.10-02 is correct. Because the wrong setting of Pr.10-02 will cause wrong position of magnetic pole and also the wrong angle between magnetic pole and PG origin

For setting 2: Starting auto tuning by pressing RUN key and it will write the measure value into Pr.08-05, Pr.08-07 (Rs, Lq) and Pr.08-08 (back EMF).

The steps to AUTO-Tuning are: (Static measure)

1. Make sure that all the parameters are set to factory settings and the motor wiring is correct
2. Motor: Fill in Pr.08-01, Pr.08-02, Pr.08-03 and Pr.08-04 with correct values. Refer to motor capacity to set accel./decel. time
3. When Pr.08-00 is set to 2, the AC motor drive will execute auto-tuning immediately after receiving a "RUN" command. (NOTE: the motor will run! The shaft needs to be locked with external force)
4. After executing, Check if all values are filled in Pr.08-05 and Pr.08-07

NOTE

- The rated speed can't be larger or equal to 120f/p.
- Note that if the electromagnetic valve and brake is not controlled by the AC motor drive, release it manually
- It is recommended to set Pr.08-00 to 1 (unloaded motor) for the accurate calculation. If it needs to execute this function with loaded motor, balance the carriage before execution.
- if it doesn't allow balancing the carriage in the measured environment, it can set Pr.08-00=3 for executing this function. It can execute this function with loaded motor by setting Pr.08-00=3. It will have a difference

of 15~30° by the different encoder type. Also refer to the referent table for tuning in Pr10-00 <PG Signal Type>.

- It will display the warning message “Auto tuning” on the digital keypad during measuring until the measure is finished. Then, the result will be saved into Pr.08-09.
- It will display “Auto Tuning Err” on the keypad when stopping by the fault of the AC motor drive or human factor to show the failed detection. At this moment, please check the connections of the wirings of the AC motor drives. If it displays “PG Fbk Error” on the digital keypad, please change the setting of Pr.10-02 (if it is set to 1, please change it to 2). If it displays “PG Fbk Loss” on the digital keypad, please check the feedback of Z-phase pulse.

08-01 Full-load Current of Motor

Control Mode **FOCPM** Unit: Amper Factory Setting:###
 Settings (40~120%) *00-01 Amps

📖 This value should be set according to the rated frequency of the motor as indicated on the motor nameplate. The factory setting is 90% X rated current.
 Example: if the rated current for 7.5hp (5.5kW) models is 25A and the factory setting is 22.5A. In this way, the current range will be from 10A (25*40%) to 30A (25*120%).

↗ **08-02** Rated Power of Motor

Control Mode **FOCPM** Factory Setting:###
 Settings 0.00~655.35 kW

📖 It is used to set rated power of the motor. The factory setting is the power of the drive.

↗ **08-03** Rated Speed of Motor (rpm)

Control Mode **FOCPM** Factory Setting:1710
 Settings 0~65535 rpm

📖 It is used to set the rated speed of the motor and need to set according to the value indicated on the motor nameplate.

08-04 Number of Motor Poles

Control Mode **FOCPM** Factory Setting:4
 Settings 2~96

📖 It is used to set the number of motor poles (must be an even number).

08-05 Rs of Motor

Control Mode **FOCPM** Factory Setting:0.000
 Settings 0.000~65.535Ω



08-06 Ld of Motor

08-07 Lq of Motor

Control Mode **FOCPM** Factory Setting:0.0
 Settings 0.0~6553.5mH

08-08 Back Electromotive Force

Control Mode **FOCPM** Factory Setting:0.0
 Settings 0.0~6553.5Vrms

-  This parameter is used to set back electromotive force (phase-phase RMS value) when the motor is operated in the rated speed.
-  It can get RMS value by Pr.08-00=2 (Motor Auto Tuning).



08-09 Angle between Magnetic Pole and PG Origin

Control Mode **FOCPM** Factory Setting:360.0
 Settings 0.0~360.0°

-  This function is used to measure the angle between magnetic pole and PG origin.

08-10 Magnetic Pole Re-orientation

Control Mode **FOCPM** Factory Setting:0
 Settings 0: Disable
 1: Enable

-  Use with Pr.11-00 bit15=1.
-  This function is used for searching magnetic pole position and only for permanent magnet motor.
-  When it doesn't have origin-adjustment for encoder (Pr.08-09 is 360.0), it can only ensure that the motor operation efficiency can be up to 86% of the best efficiency. In this situation, when the operation efficiency needs to be improved, user can re-power on or set Pr.08-10 to 1 to get the magnetic pole orientation

09 Communication Parameters

When the AC motor drive is controlled by RS-485 serial communication, a converter, VFD-USB01 or IFD8500, should be connected between the AC motor drive and PC.

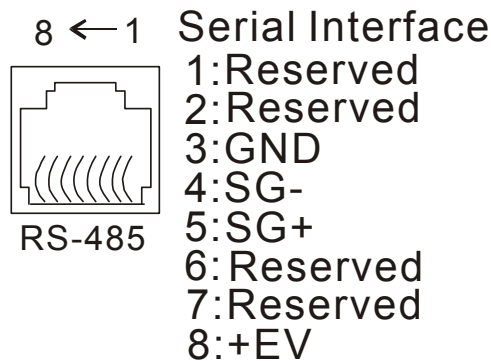

When USB01 needs to use RS-485 port, set the communication speed as 19.2kbits/s and protocol as 8, N,2 for RTU on the computer terminal.

✎ **09-00** Communication Address Factory Setting:1

Settings 1~254

If the AC motor drive is controlled by RS-485 serial communication, the communication address for this drive must be set via this parameter. And the communication address for each AC motor drive must be different and unique.

✎ **09-01** Transmission Speed Factory Setting:9.6

Control Mode **VF VFBG SVC FOC PG TQCPG FOC PM**

Settings 4.8~115.2kbits/s

This parameter is used to set the transmission speed between the RS485 master (PLC, PC, etc.) and AC motor drive.

✎ **09-02** Transmission Fault Treatment Factory Setting:3

Control Mode **VF VFBG SVC FOC PG TQCPG FOC PM**

Settings 0: Warn and keep operating
1: Warn and RAMP to stop
2: Reserved
3: No action and no display

This parameter is set to how to react if transmission errors occur

✎ **09-03** Time-out Detection Factory Setting:0.0

Control Mode **VF VFBG SVC FOC PG TQCPG FOC PM**

Settings 0.0~100.0sec
0.0: disable

It is used to set the communication time-out time.

09-04 Communication Protocol

Control Mode **VF** **VFP** **SVC** **FOCPG** **TQCPG** **FOCPM** Factory Setting:13

Settings

- 0 : 7 · N · 1 for ASCII
- 1 : 7 · N · 2 for ASCII
- 2 : 7 · E · 1 for ASCII
- 3 : 7 · O · 1 for ASCII
- 4 : 7 · E · 2 for ASCII
- 5 : 7 · O · 2 for ASCII
- 6 : 8 · N · 1 for ASCII
- 7 : 8 · N · 2 for ASCII
- 8 : 8 · E · 1 for ASCII
- 9 : 8 · O · 1 for ASCII
- 10 : 8 · E · 2 for ASCII
- 11 : 8 · O · 2 for ASCII
- 12 : 8 · N · 1 for RTU
- 13 : 8 · N · 2 for RTU
- 14 : 8 · E · 1 for RTU
- 15 : 8 · O · 1 for RTU
- 16 : 8 · E · 2 for RTU
- 17 : 8 · O · 2 for RTU

Control by PC or PLC (Computer Link)

Users can select the desired mode along with the RS-485 serial port communication protocol in Pr.09-00.

 MODBUS ASCII (American Standard Code for Information Interchange) : Each byte data is the combination of two ASCII characters. For example, a 1-byte data: 64 Hex, shown as '64' in ASCII, consists of '6' (36Hex) and '4' (34Hex).

1. Code Description:

Communication protocol is in hexadecimal, ASCII: "0", "9", "A", "F", every 16 hexadecimal represent ASCII code. For example:

Character	'0'	'1'	'2'	'3'	'4'	'5'	'6'	'7'
ASCII code	30H	31H	32H	33H	34H	35H	36H	37H

Character	'8'	'9'	'A'	'B'	'C'	'D'	'E'	'F'
ASCII code	38H	39H	41H	42H	43H	44H	45H	46H

2. Data Format

10-bit character frame (For ASCII):

(Format: 7, N, 2)

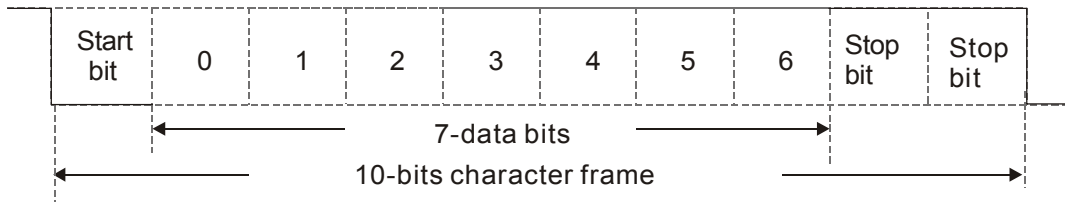

(Format: 7, E, 1)

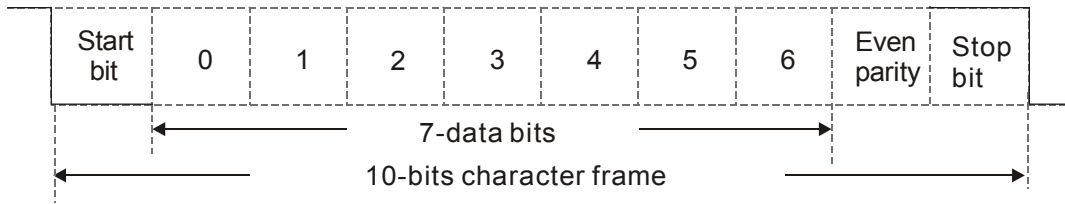

(Format: 7, O, 1)

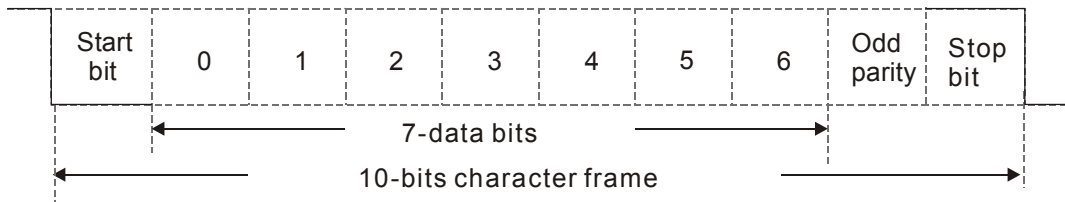

11-bit character frame (For RTU)

(Format: 8, N, 2)

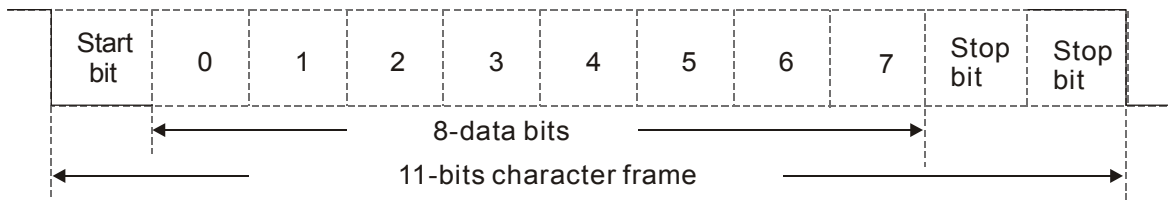

(Format: 8, E, 1)

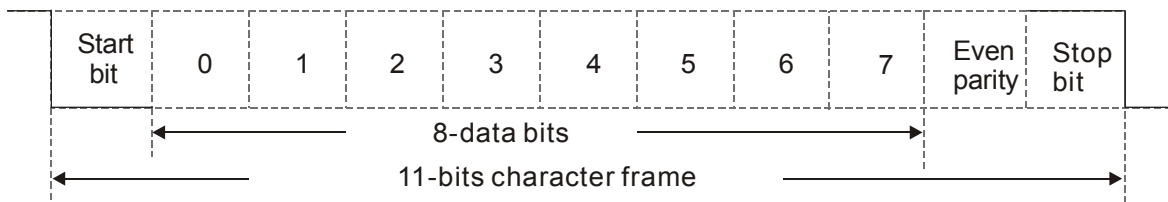

(Format: 8, O, 1)

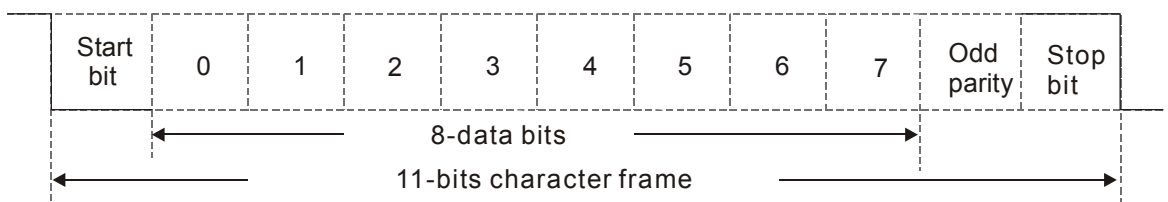

3. Communication Protocol

3.1 Communication Data Frame

ASCII mode

STX	Start character ':' (3AH)
Address Hi	Communication address: 8-bit address consists of 2 ASCII codes
Address Lo	
Function Hi	Command code: 8-bit command consists of 2 ASCII codes
Function Lo	
DATA (n-1) to DATA 0	Contents of data: Nx8-bit data consist of 2n ASCII codes n<=16, maximum of 32 ASCII codes
LRC CHK Hi	LRC check sum: 8-bit check sum consists of 2 ASCII codes
LRC CHK Lo	
END Hi	End characters: END1= CR (0DH), END0= LF(0AH)
END Lo	

RTU mode:

START	A silent interval of more than 10 ms
Address	Communication address: 8-bit address
Function	Command code: 8-bit command
DATA (n-1) to DATA 0	Contents of data: n×8-bit data, n<=16
CRC CHK Low	CRC check sum: 16-bit check sum consists of 2 8-bit characters
CRC CHK High	
END	A silent interval of more than 10 ms

3.2 Address (Communication Address)

Valid communication addresses are in the range of 0 to 254. A communication address equal to 0, means broadcast to all AC drives (AMD). In this case, the AMD will not reply any message to the master device.

00H: broadcast to all AC drives

01H: AC drive of address 01

0FH: AC drive of address 15

10H: AC drive of address 16

:

FEH: AC drive of address 254

3.3 Function (Function code) and DATA (data characters)

The format of data characters depends on the function code.

(1) 03H: read data from register

Example: reading continuous 2 data from register address 2102H, AMD address is 01H.

ASCII mode:

Command Message:		Response Message:	
STX	'.'	STX	'.'
Address	'0'	Address	'0'
	'1'		'1'
Function	'0'	Function	'0'
	'3'		'3'
Starting address	'2'	Number of data (count by byte)	'0'
	'1'		'4'
	'0'	Content of starting address 2102H	'1'
	'2'		'7'
Number of data (count by word)	'0'	Content of address 2103H	'7'
	'0'		'0'
	'0'		'0'
	'2'		'0'
LRC Check	'D'	LRC Check	'0'
	'7'		'0'
END	CR	END	'7'
	LF		'1'
			CR
			LF

RTU mode:

Command & Message:		Response Message:	
Address	01H	Address	01H
Function	03H	Function	03H
Starting data address	21H	Number of data (count by byte)	04H
	02H		Content of data address 2102H
Number of data (count by world)	00H	Content of data address 2103H	
	02H		00H
CRC CHK Low	6FH	CRC CHK Low	FEH
CRC CHK High	F7H	CRC CHK High	5CH

(2) 06H: single write, write single data to register.

Example: writing data 6000(1770H) to register 0100H. AMD address is 01H.

ASCII mode:

Command & Message:		Response Message:	
STX	'.'	STX	'.'
Address	'0'	Address	'0'
	'1'		'1'
Function	'0'	Function	'0'
	'6'		'6'
Data address	'0'	Data address	'0'
	'1'		'1'
	'0'		'0'
	'0'		'0'
Data content	'1'	Data content	'1'
	'7'		'7'
	'7'		'7'
	'0'		'0'
LRC Check	'7'	LRC Check	'7'
	'1'		'1'
END	CR	END	CR
	LF		LF

RTU mode:

Command & Message:		Response Message:	
Address	01H	Address	01H
Function	06H	Function	06H
Data address	01H	Data address	01H
	00H		00H
Data content	17H	Data content	17H
	70H		70H
CRC CHK Low	86H	CRC CHK Low	86H
CRC CHK High	22H	CRC CHK High	22H

(3) 10H: write multiple registers (write multiple data to registers) (at most 20 sets of data can be written simultaneously)

Example: Set the multi-step speed,

Pr.04-00=50.00 (1388H), Pr.04-01=40.00 (0FA0H). AC drive address is 01H.

ASCII mode

Command Message:		Response Message:	
STX	‘.’	STX	‘.’
ADR 1	‘0’	ADR 1	‘0’
ADR 0	‘1’	ADR 0	‘1’
CMD 1	‘1’	CMD 1	‘1’
CMD 0	‘0’	CMD 0	‘0’
Target Register	‘0’	Target Register	‘0’
	‘5’		‘5’
	‘0’		‘0’
	‘0’		‘0’
Number of Register (Count by word)	‘0’	Number of Register (Count by word)	‘0’
	‘0’		‘0’
	‘0’		‘0’
	‘2’		‘2’
Number of Register (Count by byte)	‘0’	LRC Check	‘E’
	‘4’		‘8’
The first data content	‘1’	END	CR
	‘3’		LF
	‘8’		
	‘8’		
The second data content	‘0’		
	‘F’		
	‘A’		
	‘0’		
LRC Check	‘9’		
	‘A’		
END	CR		
	LF		

RTU mode

Command Message:		Response:	
ADR	01H	ADR	01H
CMD	10H	CMD 1	10H
Target Register	05H 00H	Target Register	05H 00H
Number of Register (Count by word)	00H 02H	Number of Register (Count by word)	00H 02H
Number of Register(Byte)	04	CRC Check Low	41H
The first Data content	13H 88H	CRC Check High	04H
The second Data content	0FH A0H		
CRC Check Low	'9'		
CRC Check High	'A'		

3.4 Check Sum

ASCII mode (LRC Check)

LRC (Longitudinal Redundancy Check) is calculated by summing up the values of the bytes from ADR1 to the last data character then calculating the hexadecimal representation of the 2's-complement negation of the sum.

For example,

$01H+03H+21H+02H+00H+02H=29H$, the 2's-complement negation of 29H is **D7H**. For example.

RTU mode (CRC check)

CRC (Cyclical Redundancy Check) is calculated by the following steps:

Step 1: Load a 16-bit register (called CRC register) with FFFFH.

Step 2: Exclusive OR the first 8-bit byte of the command message with the low order byte of the 16-bit CRC register, putting the result in the CRC register.

Step 3: Examine the LSB of CRC register.

Step 4: If the LSB of CRC register is 0, shift the CRC register one bit to the right with MSB zero filling, then repeat step 3. If the LSB of CRC register is 1, shift the CRC register one bit to the right with MSB zero filling, Exclusive OR the CRC register with the polynomial value A001H, then repeat step 3.

Step 5: Repeat step 3 and 4 until eight shifts have been performed. When this is done, a complete 8-bit byte will have been processed.

Step 6: Repeat step 2 to 5 for the next 8-bit byte of the command message. Continue doing this until all bytes have been processed. The final contents of the CRC register are the CRC value. When transmitting the CRC value in the message, the upper and lower bytes of the CRC value must be swapped, i.e. the lower order byte will be transmitted first.

The following is an example of CRC generation using C language. The function takes two arguments:

```

unsigned char* data    ← // a pointer to the message buffer
unsigned char length  ← // the quantity of bytes in the message buffer
unsigned int crc_chk(unsigned char* data, unsigned char length)
{
    int j;
    unsigned int reg_crc=0xffff;
    while(length--){
        reg_crc ^= *data++;
        for(j=0;j<8;j++){
            if(reg_crc & 0x01){ /* LSB(b0)=1 */
                reg_crc=(reg_crc>>1) ^ 0xa001;
            }else{
                reg_crc=reg_crc >>1;
            }
        }
    }
}

return reg_crc;                // return register to CRC

```

3.5 Address List

The contents of available addresses are shown as below:

Content	Address	Function	
AC drive Parameters	GGnnH	GG means parameter group, nn means parameter number, for example, the address of Pr 4-01 is 0401H. Referencing to chapter 5 for the function of each parameter. When reading parameter by command code 03H, only one parameter can be read at one time.	
Command Write only	2000H	Bit 0-3	0: No function 1: Stop 2: Run 3: Jog + Run
Status monitor Read only	2001H	Bit 4-5	00B: No function 01B: FWD 10B: REV 11B: Change direction
		Bit 6-7	00B: 1st accel/decel 01B: 2nd accel/decel 10B: 3rd accel/decel 11B: 4th accel/decel
		Bit 8-11	Represented 16 step speeds.
		Bit 12	1: disable bit 06-11
		Bit 13~14	00B: No function
			01B: operated by digital keypad
			02B: operated by Pr.00-15 setting
	Bit 15	Reserved	
	2002H	Bit 0	1: EF (external fault) on
		Bit 1	1: Reset
		Bit 2	1: B.B. ON
		Bit 3-15	Reserved
	2100H	Fault code: refer to Pr.06-16 to Pr.06-21	
	2119H	Bit 0-Bit 1	00: Stop
			01: deceleration
			10: Ready for operation
			11: operation
		Bit 2	1: JOG command
		Bit 3-Bit 4	00: FWD command, FWD output
			01: FWD command, REV output
			10: REV command, FWD output
			11: Reserved
		Bit 5	Reserved
Bit 6		Reserved	
Bit 7		Reserved	
Bit 8		1: Master frequency Controlled by communication interface	
Bit 9	1: Master frequency controlled by analog/external terminals signal		
Bit 10	1: Operation command controlled by communication interface		
Bit 11	1: Parameters have been locked		
Bit 12	1: enable to copy parameter from keypad		
Bit 13-15	Reserved		
2102H	Frequency command (F)		
2103H	Output frequency (H)		
2104H	Output current (Axxx.X)		
2105H	DC-BUS Voltage (Uxxx.X)		
2106H	Output voltage (Exxx.X)		
2107H	Current step number of Multi-Step Speed Operation		
2116H	Multi-function display (Pr.00-04)		
2120H	Frequency command when malfunction		
2121H	Output frequency when malfunction		
2122H	Output current when malfunction		

Content	Address	Function
	2123H	Motor frequency when malfunction
	2124H	Output voltage when malfunction
	2125H	DC-bus voltage when malfunction
	2126H	Output power when malfunction
	2127H	Output torque when malfunction
	2128H	IGBT Temperature of Power Module at Present Fault
	2129H	Input status of multi-function terminal when malfunction (format is the same as Pr.00-04=16)
	212AH	Output status of multi-function terminal when malfunction (format is the same as Pr.00-04=17)
	212BH	Drive status when malfunction (format is the same as 2119H)
	2201H	Pr.00-05 user-defined setting
	2203H	AUI1 analog input (XXX.XX %)
	2204H	ACI analog input (XXX.XX %)
	2205H	AUI2 analog input (XXX.XX %)
	2206H	Display temperature of IGBT (°C)
	2207H	Display temperature of heatsink (°C) (only for model 40HP and above)
	2208H	Digital input state
	2209H	Digital output state

3.6 Exception Response

The AC motor drive is expected to return a normal response after receiving command messages from the master device. The following depicts the conditions when no normal response is replied to the master device.

The AC motor drive does not receive the messages due to a communication error; thus, the AC motor drive has no response. The master device will eventually process a timeout condition.

The AC motor drive receives the messages without a communication error, but cannot handle them. An exception response will be returned to the master device and an error message “CExx” will be displayed on the keypad of AC motor drive. The xx of “CExx” is a decimal code equal to the exception code that is described below.

In the exception response, the most significant bit (bit7) of the original command code is set to 1 (function code and 80H), and an exception code which explains the condition that caused the exception is returned.

Example:

ASCII mode:		RTU mode	
STX	‘.’	Address	01H
Address	‘0’	Function	86H
	‘1’	Exception code	02H
Function	‘8’	CRC CHK Low	C3H
	‘6’	CRC CHK High	A1H
Exception code	‘0’		
	‘2’		
LRC CHK	‘7’		
	‘7’		
END	CR		
	LF		

Description of Exception Codes:

Exception Code	Description
1	Illegal function code: The function code received in the command message is not available for the AC motor drive.
2	Illegal data address: The data address received in the command message is not available for the AC motor drive.
3	Illegal data value: The data value received in the command message is not available for the AC drive.
4	Slave device failure: The AC motor drive is unable to perform the requested action.
10	Communication time-out: If Pr.09-03 is not equal to 0.0, Pr.09-02=0~1, and there is no communication on the bus during the Time Out detection period (set by Pr.09-03), “cE10” will be shown on the keypad.

↗ **09-05** Response Delay Time

Control Mode **VF VFPG SVC FOC PG TQCPG FOC PM** Factory Setting:2.0
 Settings 0.0~200.0ms

📖 In case if the host computer didn't finish the transmitting/receiving process, this parameter is the response delay time after AC drive receives communication command as shown in the following.

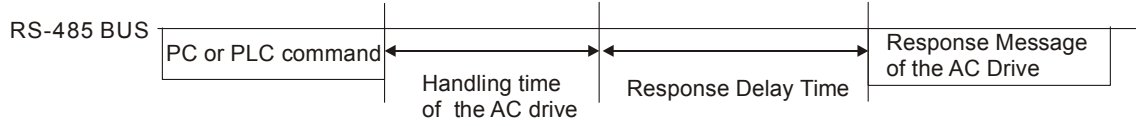

10 Speed Feedback Control Parameters

In this parameter group, ASR is the abbreviation for Adjust Speed Regulator and PG is the abbreviation for Pulse Generator.

10-00

Selection of Encoder

Control Mode **VFPG** **FOCPG TQCPG FOCPM** Factory Setting:0

- Settings
- 0: No function
 - 1: ABZ
 - 2: ABZ+Hall
 - 3: SIN/COS + Sinusoidal
 - 4: SIN/COS + Endat
 - 5: SIN/COS
 - 6: SIN/COS + Hiperface

- When Pr.10-00 is set to 3, encoder will have one sine and one cosine signal for each revolution. The signal must be: 0.75 to 1.2Vpp for the amplitude with phase angle $90^{\circ} \pm 5$ elec. (EX: ERN 1185 ERN 1387)
- When setting is 4 or 6, it needs to wait for 2 seconds after applying the power to execute RUN command.
- Detection of the magnetic pole:
Setting 1 or 5: The AC motor drive will output short circuit to detect the position of the magnetic pole. At this moment, the motor will generate a little noise.
Setting 2: The AC motor drive will detect the position of the magnetic pole by the UVW signal of encoder.
Setting 3: The AC motor drive will detect the position of the magnetic pole by the sine signal of encoder.
Setting 4 or 6: The AC motor drive will detect the position of the magnetic pole by the communication signal of encoder.

Reference table for tuning

Setting of PG signal type	PG signal type	Applicable PG card	Pr.08-00=1	Pr.08-00=3
10-00=1	A, B, Z	EMVL-PGABO/ABL	Motor will run	Motor will run
10-00=2	A, B, Z+U, V, W	EMVL-PGABL	Motor will run	Motor will run
10-00=3	SIN/COS+ Sinusoidal	EMVL-PGH01/02	Motor will run	Motor will run
10-00=4	SIN/COS+Endat	EMVL-PGS01	Motor will run	Motor won't run
10-00=5	SIN/COS	EMVL-PGH01/02	Motor will run	Motor will run
10-00=6	SIN/COS + Hiperface	EMVL-PGS01	Motor will run	Motor won't run

10-01



Encoder Pulse

Control Mode **VFPG** **FOCPG TQCPG FOCPM** Factory Setting:600

- Settings 1~25000

- A Pulse Generator (PG) or encoder is used as a sensor that provides a feedback signal of the motor speed. This parameter defines the number of pulses for each cycle of the PG control.

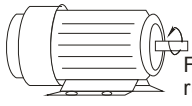
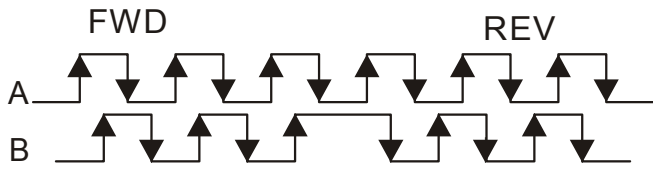
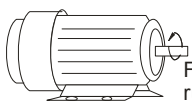
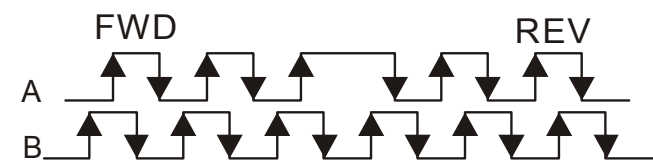
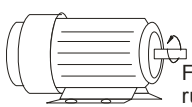
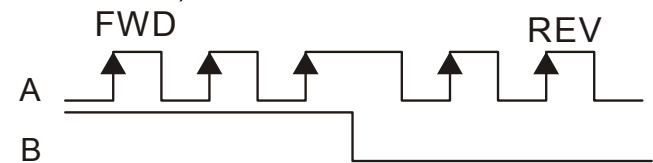
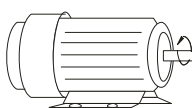
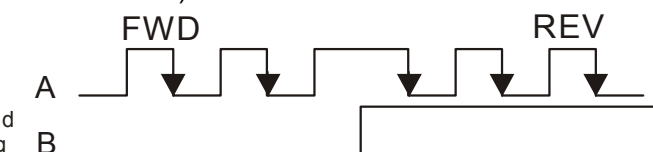
10-02 Encoder Input Type Setting

Control Mode	VFBPG	FOCPG TQCPG FOCPM	Factory Setting:0
Settings	0	Disable	
		Phase A leads in a forward run command and phase B leads in a reverse run command	
	1	 <p>Phase B leads in a forward run command and phase A leads in a reverse run command</p> 	
	2	 <p>Phase A is a pulse input and phase B is a direction input. (low input=reverse direction, high input=forward direction)</p> 	
	3	 <p>Phase A is a pulse input and phase B is a direction input. (low input=forward direction, high input=reverse direction)</p> 	
	4	 <p>Single-phase input</p> 	
	5	 	

 It is helpful for the stable control by inputting correct pulse type.

10-03 Encoder Feedback Fault Treatment (PGF1, PGF2)

Control Mode	VFBPG	FOCPG TQCPG FOCPM	Factory Setting:2
Settings	0: Fault and keep operation		
	1: Fault and RAMP to stop		
	2: Fault and stop operation		

10-04 Detection Time for Encoder Feedback Fault

Control Mode	VFBPG	FOCPG TQCPG FOCPM	Factory Setting:1.0
Settings	0.0~10.0sec		

 When PG loss, encoder signal error, pulse signal setting error or signal error, if time exceeds the detection time for encoder feedback fault (Pr.10-04), the PG signal error will occur. Refer to the Pr.10-03 for encoder feedback fault treatment.

↗ 10-11	ASR (Auto Speed Regulation) Control (P) of Zero Speed
Control Mode	VF VFPG SVC FOCPG FOCPM Factory Setting:100.0
Settings	0.0~500.0%
↗ 10-12	ASR (Auto Speed Regulation) Control (I) of Zero Speed
Control Mode	VF VFPG SVC FOCPG FOCPM Factory Setting:0.100
Settings	0.000~10.000sec
↗ 10-13	ASR (Auto Speed Regulation) control (P) 1
Control Mode	VF VFPG SVC FOCPG FOCPM Factory Setting:100.0
Settings	0.0~500.0%
↗ 10-14	ASR (Auto Speed Regulation) control (I) 1
Control Mode	VF VFPG SVC FOCPG FOCPM Factory Setting:0.100
Settings	0.000~10.000sec
↗ 10-15	ASR (Auto Speed Regulation) control (P) 2
Control Mode	VF VFPG SVC FOCPG FOCPM Factory Setting:100.0
Settings	0.0~500.0%
↗ 10-16	ASR (Auto Speed Regulation) control (I) 2
Control Mode	VF VFPG SVC FOCPG FOCPM Factory Setting:0.100
Settings	0.000~10.000sec
↗ 10-17	ASR 1/ASR2 Switch Frequency
Control Mode	VF VFPG SVC FOCPG FOCPM Factory Setting:7.00
Settings	0.00~400.00Hz 0: Disable

📖 ASR P determines Proportional control and associated gain (P). ASR I determines integral control and associated gain (I).

📖 When integral time is set to 0, it is disabled. Pr.10-17 defines the switch frequency for the ASR1 (Pr.10-13, Pr.10-14) and ASR2 (Pr.10-15, Pr.10-16).

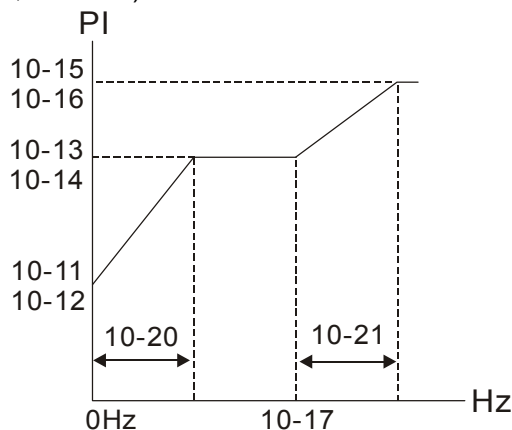

📖 When using multi-function input terminals to switch ASR1/ASR2, the diagram will be shown as follows.

Setting multi-function input terminal to 17
(ASR1/ASR2 switch)

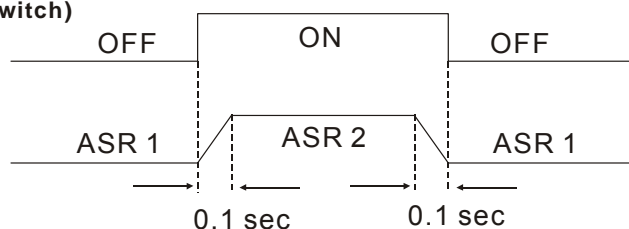

↗ **10-18** ASR Primary Low Pass Filter Gain
 Control Mode **VF VFPG SVC FOCPG FOCPM** Factory Setting:0.008
 Settings 0.000~0.350sec

- 📖 It defines the filter time of the ASR command.
- 📖 When setting to 1, this function is disabled.

↗ **10-19** Zero Speed Gain (P)
 Control Mode **FOCPM** Factory Setting:80.00
 Settings 0~655.00%

- 📖 When Pr.11-00 is set to Bit 7=1, Pr.10-19 is valid

↗ **10-20** Zero Speed/ASR1 Width Adjustment
 Control Mode **VFPG FOCPG FOCPM** Factory Setting:5.00
 Settings 0.00~400.00Hz

↗ **10-21** ASR1/ASR2 Width Adjustment
 Control Mode **VFPG FOCPG FOCPM** Factory Setting:5.00
 Settings 0.00~400.00Hz

- 📖 These two parameters are used to decide width of slope of ASR command during zero speed to low speed or Pr.10-17 to high speed.

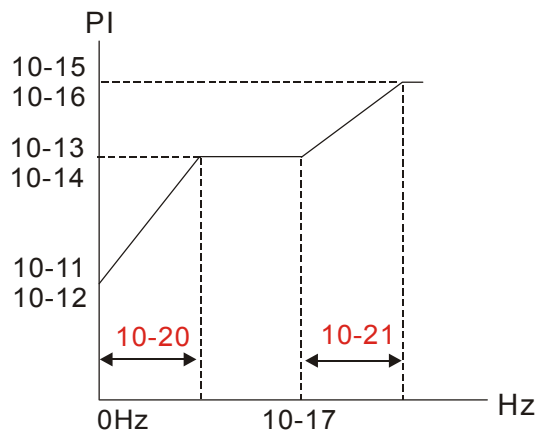

↗ **10-22** Zero Speed Position Holding Time
 Control Mode **FOCPM** Factory Setting:0.250
 Settings 0.001~65.535 sec

↗ **10-23** Filter Time at Zero Speed
 Control Mode **FOCPM** Factory Setting:0.004
 Settings 0.001~65.535 sec

↗ **10-24** Time for Executing Zero Speed
 Control Mode **FOCPM** Factory Setting:0
 Settings 0: After the brake release set in Pr.02-29
 1: After the brake signal input (Pr.02-01~02-08 is set to 42)

- 📖 When Pr.10-24=0, the zero speed control needs to be used with Pr.02-29. (refer to the explanations in Pr.02-32)

↗ **10-25** Elevator Leveling (Zero Speed Gain P)
 Control Mode **VF VFPG SVC FOCPG FOCPM** Factory Setting:100.0
 Settings 0~1000.0%

- 10-26 Elevator Leveling (Zero Speed Integral I)

Control Mode	VF	VFPG	SVC	FOCPG	FOCPM	Factory Setting:0.100
Settings	0~10.000sec					
- 10-27 Elevator Starting (Zero Speed Gain P)

Control Mode	VF	VFPG	SVC	FOCPG	FOCPM	Factory Setting:100.0
Settings	0~1000.0%					
- 10-28 Elevator Starting (Zero Speed Integral I)

Control Mode	VF	VFPG	SVC	FOCPG	FOCPM	Factory Setting:0.100
Settings	0~10.000sec					

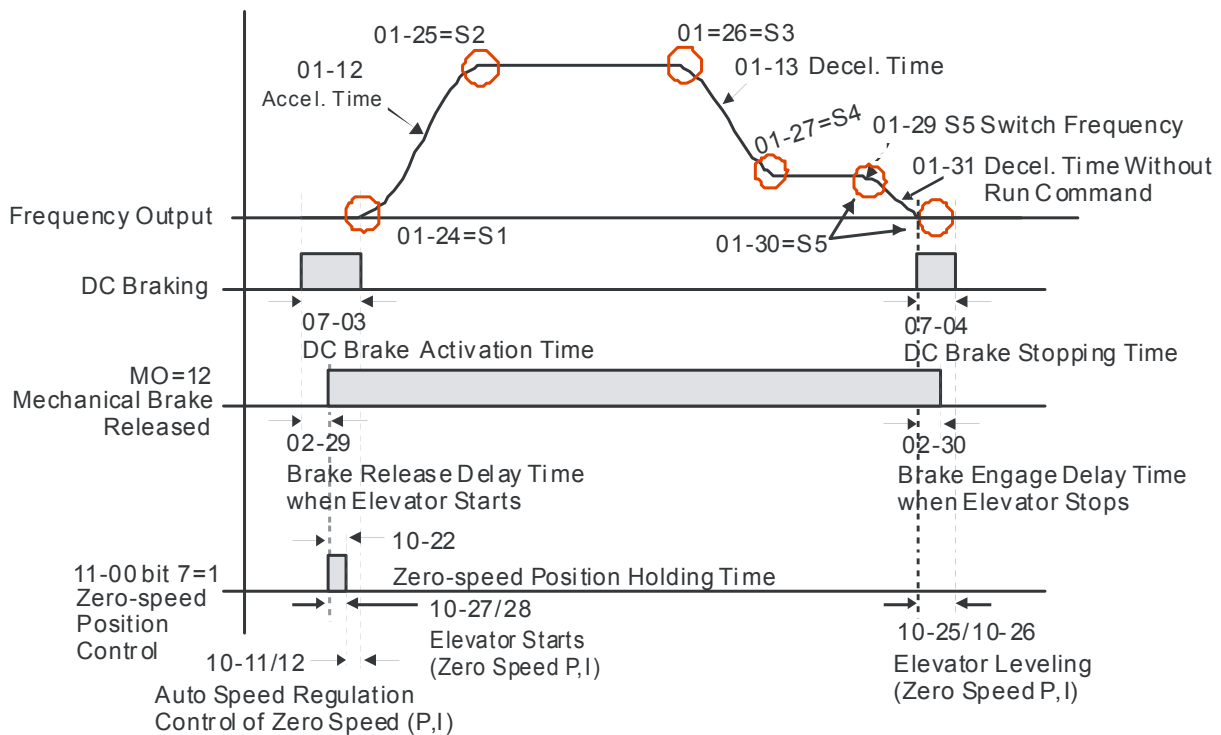

- 10-29 Setting of PG card frequency division output

Control Mode	VFPG	FOCPG	FOCPM	Factory Setting:0
Settings	0~32			
- 10-30 Type of PG card frequency division output

Control Mode	VFPG	FOCPG	FOCPM	Factory Setting:0
Settings	0x00~0x02			

See CH07 for more information about PG card.

11 Advanced Parameters

Control Mode	FOCPG	FOCPM	Factory Setting:0
Settings	Bit 0=0: No function Bit 0=1: ASR Auto tuning, PDFF enable Bit 7=0: No function Bit 7=1: When position control is enabled, it doesn't need to set Pr.07-02 (DC Brake Current Level) Bit 15=0: When power is applied, it will detect the position of magnetic pole again Bit 15=1: when power is applied, it will start from the magnetic pole position of previous power failure		

Bit 0=1: PDFF function is enabled and system will generate an ASR setting, Pr. 10-11~10-16 will be invalid and Pr.11-09 to 11-10 will be valid.

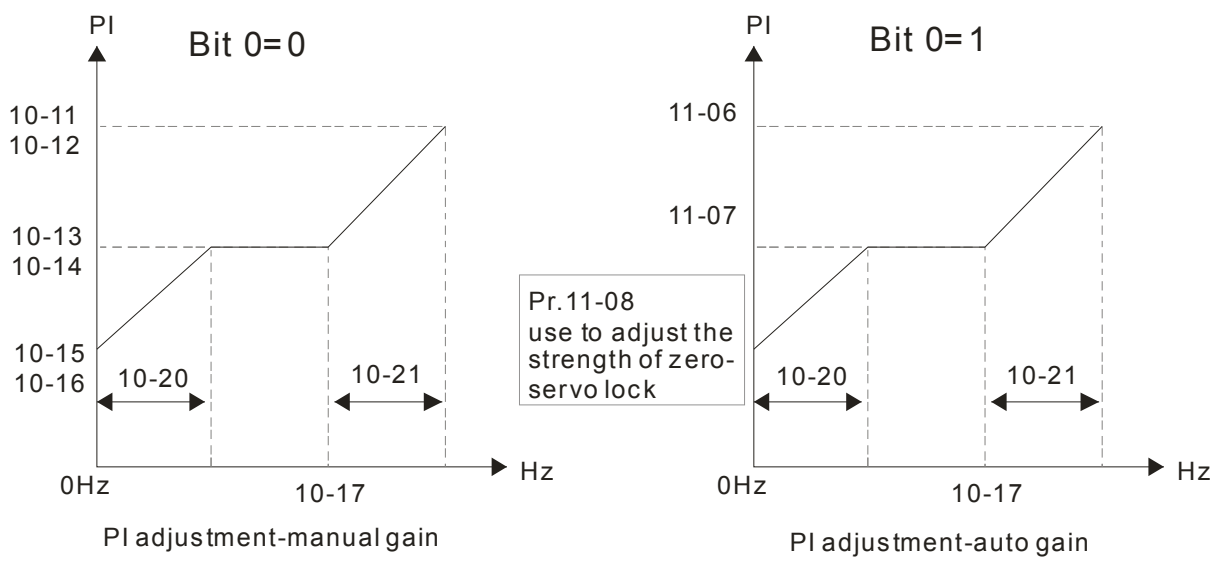
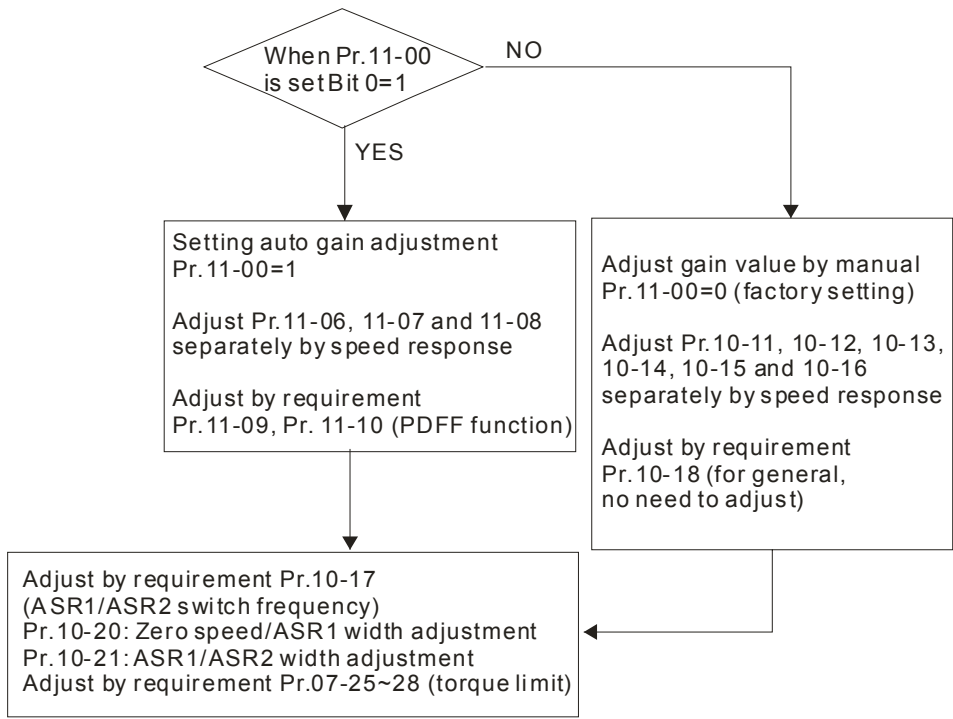

➤ **11-01** Elevator Speed

Control Mode	FOCPG	FOCPM	Factory Setting:1
Settings	0.10~4.00 m/s		

➤ **11-02** Sheave Diameter

Control Mode	FOCPG	FOCPM	Factory Setting:400
Settings	100~2000 mm		

➤ **11-03** Mechanical Gear Ratio

Control Mode	FOCPG	FOCPM	Factory Setting:1
Settings	1~100		

11-04 Suspension Ratio

Control Mode	FOCPG	FOCPM	Factory Setting:1
Settings	0= 1 : 1		
	1= 2 : 1		

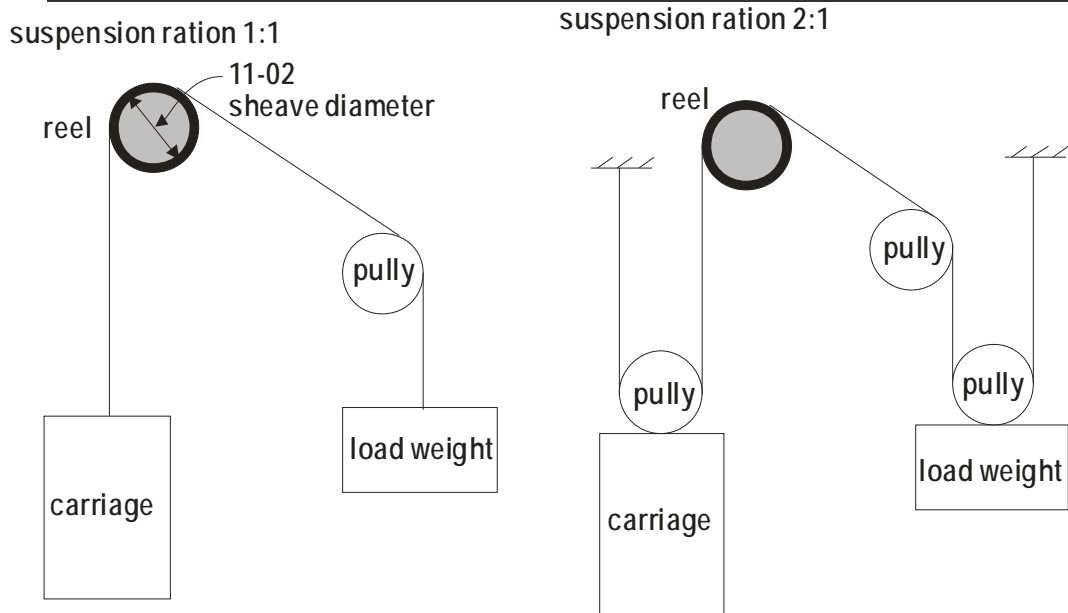

➤ **11-05** Inertial Ratio

Control Mode	FOCPG	FOCPM	Factory Setting:40
Settings	1~300%		

📖 The load inertia can be calculated by the settings of motor parameter, Pr.11-02 Sheave Diameter, Pr.11-14 Motor Current at Accel. and Pr.11-15 Elevator Acceleration. This parameter can be used to adjust inertia ratio of load.

➤ **11-06** Zero-speed Bandwidth

Control Mode	FOCPG	FOCPM	Factory Setting:10
Settings	0~40Hz		

➤ **11-07** Low-speed Bandwidth

Control Mode	FOCPG	FOCPM	Factory Setting:10
Settings	0~40Hz		

➤ **11-08** High-speed Bandwidth

Control Mode	FOCPG	FOCPM	Factory Setting:10
Settings	0~40Hz		

📖 After estimating inertia and set Pr.11-00=1 (auto tuning), user can adjust parameters Pr.11-06, 11-07 and 11-08 separately by speed response. The larger number you set, the faster response you will get. Pr.10-08 is the switch frequency for low-speed/high-speed bandwidth.

➤ **11-09** PDFF Gain Value

Control Mode	FOCPG	FOCPM	Factory Setting:30
Settings	0~200%		

- 📖 After finishing estimating and set Pr.11-00=1 (auto tuning), using Pr.11-09/11-10 to reduce overshoot. Please adjust PDFF gain value by actual situation.
- 📖 Besides traditional PI control, it also provides PDFF function to reduce overshoot for speed control.
1. Get system inertia
 2. Set Pr.11-00 to 1
 3. Adjust Pr.11-09/11-10 (the larger number is set and the suppressed overshoot function will be better. But it needs to be used by the actual condition)

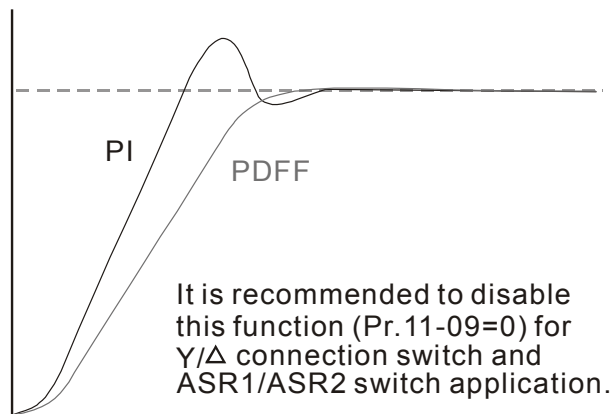

➤ **11-10** Gain for Speed Feed Forward

Control Mode	FOCPG	FOCPM	Factory Setting:0
Settings	0~500		

📖 Pr.11-09 and Pr.11-10 will be enabled when Pr.11-00 is set to Bit0=1.

➤ **11-11** Notch Filter Depth

Control Mode	FOCPG	FOCPM	Factory Setting:0
Settings	0~20db		

➤ **11-12** Notch Filter Frequency

Control Mode	FOCPG	FOCPM	Factory Setting:0.00
Settings	0.00~200.00Hz		

- 📖 This parameter is used to set resonance frequency of mechanical system. It can be used to suppress the resonance of mechanical system.
- 📖 The larger number you set Pr.11-11, the better suppression resonance function you will get.
- 📖 The notch filter frequency is the resonance of mechanical frequency.

↗	11-13	Low-pass Filter Time of Keypad Display						
	Control Mode	VF	VFPG	SVC	FOCPG	TQCPG	FOCPM	Factory Setting:0.500
		Settings	0.001~65.535 秒					
			It is used to lower the blinking frequency of LCD display.					
↗	11-14	Motor Current at Accel.						
	Control Mode						FOCPM	Factory Setting:150
		Settings	50~200%					
	11-15	Elevator Acceleration						
	Control Mode						FOCPM	Factory Setting:0.75
		Settings	0.20~2.00m/s ²					
↗	11-16	Reserved						
	Control Mode	VF	VFPG	SVC	FOCPG	TQCPG	FOCPM	Factory Setting:0
		Settings	0X0000~0XFFFF					
↗	11-17	Reserved						
	Control Mode	VF	VFPG	SVC	FOCPG	TQCPG	FOCPM	Factory Setting:###
		Settings	唯讀					
↗	11-18	Reserved						
	Control Mode	VF	VFPG	SVC	FOCPG	TQCPG	FOCPM	Factory Setting:###
		Settings	0X0000~0XFFFF					

12 User-defined Parameters

↗	12-00	Present Fault Record	Control Mode	VF	VFPG	SVC	FOCPG	TQCPG	FOCPM	Factory Setting:###
			Settings		0610					
↗	12-01	Present Fault Time of Motor Operation (min.)	Control Mode	VF	VFPG	SVC	FOCPG	TQCPG	FOCPM	Factory Setting:###
			Settings		0620					
↗	12-02	Present Fault Time of Motor Operation (day)	Control Mode	VF	VFPG	SVC	FOCPG	TQCPG	FOCPM	Factory Setting:###
			Settings		0621					
↗	12-03	Frequency Command at Present Fault	Control Mode	VF	VFPG	SVC	FOCPG	TQCPG	FOCPM	Factory Setting:###
			Settings		2120					
↗	12-04	Output Frequency at Preset Fault	Control Mode	VF	VFPG	SVC	FOCPG	TQCPG	FOCPM	Factory Setting:###
			Settings		2121					
↗	12-05	Output Current at Present Fault	Control Mode	VF	VFPG	SVC	FOCPG	TQCPG	FOCPM	Factory Setting:###
			Settings		2122					
↗	12-06	Motor Frequency at Present Fault	Control Mode	VF	VFPG	SVC	FOCPG	TQCPG	FOCPM	Factory Setting:###
			Settings		2123					
↗	12-07	Output Voltage at Present Fault	Control Mode	VF	VFPG	SVC	FOCPG	TQCPG	FOCPM	Factory Setting:###
			Settings		2124					
↗	12-08	DC-Bus Voltage at Present Fault	Control Mode	VF	VFPG	SVC	FOCPG	TQCPG	FOCPM	Factory Setting:###
			Settings		2125					
↗	12-09	Output Power at Present Fault	Control Mode	VF	VFPG	SVC	FOCPG	TQCPG	FOCPM	Factory Setting:###
			Settings		2126					

↗	12-10	Output Torque at Present Fault
Control Mode	VF VFPG SVC FOC PG TQCPG FOC PM	Factory Setting:###
	Settings 2127	
↗	12-11	IGBT Temperature of Power Module at Present Fault
Control Mode	VF VFPG SVC FOC PG TQCPG FOC PM	Factory Setting:###
	Settings 2128	
↗	12-12	Multi-function Terminal Input Status at Present Fault
Control Mode	VF VFPG SVC FOC PG TQCPG FOC PM	Factory Setting:###
	Settings 2129	
↗	12-13	Multi-function Terminal Output Status at Present Fault
Control Mode	VF VFPG SVC FOC PG TQCPG FOC PM	Factory Setting:###
	Settings 212A	
↗	12-14	Drive Status at Present Fault
Control Mode	VF VFPG SVC FOC PG TQCPG FOC PM	Factory Setting:###
	Settings 212B	
↗	12-15	Second Most Recent Fault Record
Control Mode	VF VFPG SVC FOC PG TQCPG FOC PM	Factory Setting:###
	Settings 0611	
↗	12-16	Second Most Recent Fault Time of Motor Operation (min.)
Control Mode	VF VFPG SVC FOC PG TQCPG FOC PM	Factory Setting:###
	Settings 0622	
↗	12-17	Second Most Recent Fault Time of Motor Operation (day)
Control Mode	VF VFPG SVC FOC PG TQCPG FOC PM	Factory Setting:###
	Settings 0623	
↗	12-18	Third Most Recent Fault Record
Control Mode	VF VFPG SVC FOC PG TQCPG FOC PM	Factory Setting:###
	Settings 0612	
↗	12-19	Third Most Recent Fault Time of Motor Operation (min.)
Control Mode	VF VFPG SVC FOC PG TQCPG FOC PM	Factory Setting:###
	Settings 0624	

↗	12-20	Third Most Recent Fault Time of Motor Operation (day)	Control Mode	VF	VFPG	SVC	FOCPG	TQCPG	FOCPM	Factory Setting:###
			Settings	0625						
↗	12-21	Fourth Most Recent Fault Record	Control Mode	VF	VFPG	SVC	FOCPG	TQCPG	FOCPM	Factory Setting:###
			Settings	0613						
↗	12-22	Fourth Most Recent Fault Time of Motor Operation (min.)	Control Mode	VF	VFPG	SVC	FOCPG	TQCPG	FOCPM	Factory Setting:###
			Settings	0626						
↗	12-23	Fourth Most Recent Fault Time of Motor Operation (min.)	Control Mode	VF	VFPG	SVC	FOCPG	TQCPG	FOCPM	Factory Setting:###
			Settings	0627						
↗	12-24	Fifth Most Recent Fault Record	Control Mode	VF	VFPG	SVC	FOCPG	TQCPG	FOCPM	Factory Setting:###
			Settings	0614						
↗	12-25	Fifth Most Recent Fault Time of Motor Operation (min.)	Control Mode	VF	VFPG	SVC	FOCPG	TQCPG	FOCPM	Factory Setting:###
			Settings	0628						
↗	12-26	Fifth Most Recent Fault Time of Motor Operation (day)	Control Mode	VF	VFPG	SVC	FOCPG	TQCPG	FOCPM	Factory Setting:###
			Settings	0629						
↗	12-27	Sixth Most Recent Fault Record	Control Mode	VF	VFPG	SVC	FOCPG	TQCPG	FOCPM	Factory Setting:###
			Settings	0615						
↗	12-28	Sixth Most Recent Fault Time of Motor Operation (min.)	Control Mode	VF	VFPG	SVC	FOCPG	TQCPG	FOCPM	Factory Setting:###
			Settings	062A						
↗	12-29	Sixth Most Recent Fault Time of Motor Operation (day)	Control Mode	VF	VFPG	SVC	FOCPG	TQCPG	FOCPM	Factory Setting:###
			Settings	062B						

↗ 12-30 No factory setting

↗ 12-31 No factory setting

12-00

~

User-defined Parameters

12-31

Control Mode **VF** **VFP** **SVC** **FOCPG** **TQCPG** **FOCPM** Factory Setting:-
 Settings -

📖 Users can enter the parameters from group 0 to group 11 into group 12 (it can save 32 parameters). The saved value can also be the parameter addresses (but the hexadecimal value needs to be converted to decimal value).

📖 Example 2: If it needs to enter parameter address 2102H and 211BH by the digital keypad, 211BH needs to be converted to binary value before entering.
 The setting method of 2102H

📖 **Examples of User-defined parameters**

Example 1: If you want to enter Pr.08-03 into Pr.12-00, you only need to enter 0803 into Pr.12-00. Then it will display the setting of Pr.08-03 in Pr.13-00.

Example 2: If it needs to enter parameter address 2102H and 211BH by the digital keypad, 211BH needs to be converted to binary value before entering.

The setting method of 211BH

Convert 211BH (hexadecimal) to decimal value:

$$\begin{array}{c}
 2 \ 1 \ 1 \ B \\
 \swarrow \quad \searrow \\
 1 \times 16^1 + 11 \times 16^0 = 16 + 11 = 27 \quad \text{input } 2127
 \end{array}$$

13 View User-defined Parameters

13-00

~

View User-defined Parameters

13-31

Control Mode **VF** **VFP** **SVC** **FOCP** **TQCP** **FOCP**

Factory Setting:-

Settings -

13 Warning Codes

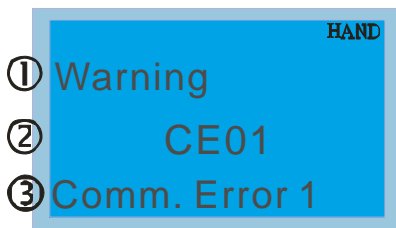

① Warning

② CE01



③ Comm. Error 1

① Display error signal

② Abbreviated error code
The code is displayed as shown on KPC-CE01.

③ Display error description

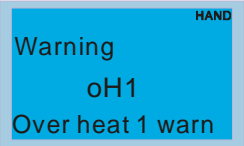
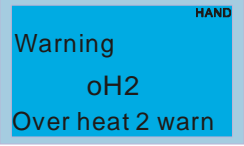
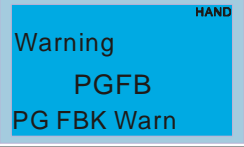
ID No.	Display on LCM Keypad	Descriptions
1		Function code defected Cause Communication error
2		Address of data defected Cause Communication error
3		Data defected Cause Communication error Communication error
4		Equipment failre at slave station Cause Communication error
5		Transmission time-out Cause Communication error
6		Keypad transmission time-out Cause Communication error
7		Keypad COPY error 1 Cause Keypad simulation error, including communication delays, communication error (keypad recived error FF86) and parameter value error.
8		Keypad COPY error 2 Cause eypad simulation done but parameter write error

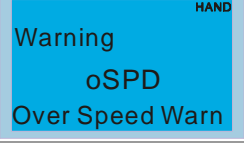
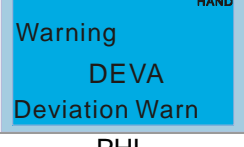
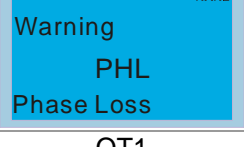
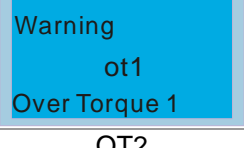
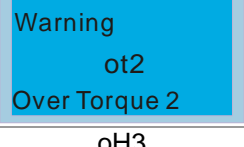
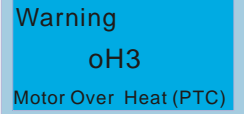
ID No.	Display on LCM Keypad	Descriptions
9	<p style="text-align: center;">oH1</p> 	<p>IGBT over-heating warning</p> <p>Cause The temperature of the heat sink and that of the IGBT are over the factory setting 85°C (Pr06-14).</p>
10	<p style="text-align: center;">oH2</p> 	<p>Capacity over-heating warning</p> <p>Cause The temperature of the heat sink and that of the IGBT are over the factory setting 85°C (Pr06-14).</p>
15	<p style="text-align: center;">PGFBK</p> 	<p>PG card feedback error</p> <p>Cause When Pr10-03 = 0 (factory setting = 2), a warning message will be displayed instead of a fault message while an error occurs.</p>
16	<p style="text-align: center;">PGL</p> 	<p>PG feedback loss.</p> <p>Cause Pr10-03 = 0 (factory setting = 2), a warning message will be displayed instead of a fault message while an error occurs.</p>
17	<p style="text-align: center;">OSPD</p> 	<p>Over-speed warning</p> <p>Cause Pr10-09 = 0 (factory setting = 2), a warning message will be displayed instead of a fault message while an error occurs.</p>
18	<p style="text-align: center;">DEVA</p> 	<p>Over speed deviation warning</p> <p>Cause Pr10-09 = 0 (factory setting = 2), a warning message will be displayed instead of a fault message while an error occurs.</p>
19	<p style="text-align: center;">PHL</p> 	<p>Phase loss</p> <p>Cause When Pr06-01 =0 (factory setting = 2), a warning message will be given instead of a fault message while a phase loss occurs.</p>
20	<p style="text-align: center;">OT1</p> 	<p>Over torque 1</p> <p>Cause When Pr06-05 =1 or 3 (factory setting = 2), a warning message will be given instead of a fault message while there is an over torque detection.</p>
21	<p style="text-align: center;">OT2</p> 	<p>Over torque 2</p> <p>Cause When Pr06-05 =1 or 3 (factory setting = 2), a warning message will be given instead of a fault message while there is an over torque detection.</p>
22	<p style="text-align: center;">oH3</p> 	<p>Motor over-heating (PTC)</p> <p>Cause When Pr06-26 =1 (factory setting = 0), a warning message will be given when there is a PTC detection.</p>

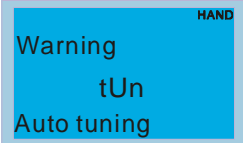
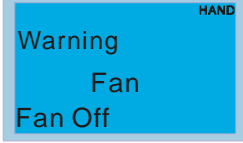
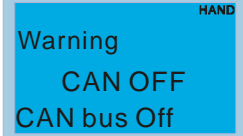
ID No.	Display on LCM Keypad	Descriptions
24	<p style="text-align: center;">oSL</p> 	<p>Over slip</p> <p>Cause When Pr05-16 =0 (factory setting = 0), a warning message will be given while the slip deviation level is over the setting at Pr05-14 and the detection time is longer than the setting at Pr05-15.</p>
25	<p style="text-align: center;">tUn</p> 	<p>Auto tuning in process</p>
26	<p style="text-align: center;">Fan</p> 	<p>Fan stop turning</p> <p>Cause When Pr06-45 bit 1 =1, a warning message will be given when the cooling fan is locked (when bit1=1, there is an output error)</p>
27	<p style="text-align: center;">CANOFF</p> 	<p>CANbus off</p> <p>Cause Error(s) occurred on CANbus</p>